



Main

Range of product	Altivar 32
Product or component type	Variable speed drive
Product destination	Asynchronous motors Synchronous motors
Product specific application	Complex machines
Function available	Configure over bluetooth
Assembly style	With heat sink
Component name	ATV32
EMC filter	Class C2 EMC filter integrated
Phase	1 phase
[Us] rated supply voltage	200...240 V - 15...10 %
Supply voltage limits	170...264 V
Supply frequency	50...60 Hz - 5...5 %
Network frequency	47.5...63 Hz
Motor power kW	0.75 kW 200...240 V
Motor power hp	1 hp 200...240 V

Complementary

Line current	10.1 A 200 V 1 phase 0.75 kW 1 hp 8.5 A 240 V 1 phase 0.75 kW 1 hp
Apparent power	2 kVA 240 V 1 phase 0.75 kW 1 hp
Prospective line I _{sc}	<= 1 kA 1 phase
Nominal output current	4.8 A 4 kHz 240 V 0.75 kW 1 hp
Maximum transient current	7.2 A 60 s 0.75 kW 1 hp
Output frequency	0.0005...0.599 kHz
Nominal switching frequency	4 kHz
Switching frequency	2...16 kHz adjustable
Speed range	1...100 asynchronous motor in open-loop mode
Speed accuracy	+/- 10 % of nominal slip 0.2 T _n to T _n
Torque accuracy	+/- 15 %
Transient overtorque	170...200 %
Braking torque	<= 170 % with braking resistor
Asynchronous motor control profile	Voltage/frequency ratio, 2 points Voltage/frequency ratio, 5 points Flux vector control without sensor - Energy Saving, NoLoad law Flux vector control without sensor, standard Voltage/frequency ratio - Energy Saving, quadratic U/f
Synchronous motor control profile	Vector control without sensor
Regulation loop	Adjustable PID regulator
Motor slip compensation	Automatic whatever the load Not available in voltage/frequency ratio (2 or 5 points) Adjustable 0...300 %
Local signalling	1 LED red drive voltage 1 LED blue bluetooth 1 LED green CANopen run 1 LED red CANopen error 1 LED red drive fault
Output voltage	<= power supply voltage
Noise level	43 dB 86/188/EEC
Insulation	Electrical between power and control
Electrical connection	Screw terminal 0.5...1.5 mm ² AWG 18...AWG 14 control Removable screw terminals 1.5...2.5 mm ² AWG 14...AWG 12 motor/braking resistor

The information provided in this documentation contains general descriptions and/or technical characteristics of the performance of the products contained herein. This documentation is not intended as a substitute for and is not to be used for determining suitability or reliability of these products for specific user applications. It is the duty of any such user or integrator to perform the appropriate and complete risk analysis, evaluation and testing of the products with respect to the relevant specific application or use thereof. Neither Schneider Electric Industries SAS nor any of its affiliates or subsidiaries shall be responsible or liable for misuse of the information contained herein.

	Screw terminal 1.5...4 mm ² AWG 14...AWG 10 power supply
Tightening torque	4.42 lbf.in (0.5 N.m) 4.4 lb/ft control 6.19 lbf.in (0.7 N.m) 7.1 lb/ft motor/braking resistor 5.31 lbf.in (0.6 N.m) 5.3 lb/ft power supply
Supply	Internal supply for reference potentiometer (1 to 10 kOhm) 10.5 V DC +/- 5 % <= 10 mA overload and short-circuit protection
Analogue input number	3
Analogue input type	Voltage AI1 0...10 V DC 30000 Ohm 10 bits Bipolar differential voltage AI2 +/- 10 V DC 30000 Ohm 10 bits Current AI3 0...20 mA (or 4-20 mA, x-20 mA, 20-x mA or other patterns by configuration) 250 Ohm 10 bits
Sampling duration	2 ms AI1, AI2, AI3 analog 2 ms AO1 analog
Response time	8 ms +/- 0.7 ms LI1...LI6 logic 2 ms R1A, R1B, R1C relay 2 ms R2A, R2C relay
Accuracy	+/- 0.2 % AI1, AI2, AI3 for a temperature of -10...60 °C +/- 0.5 % AI1, AI2, AI3 for a temperature of 25 °C +/- 1 % AO1 for a temperature of 25 °C +/- 2 % AO1 for a temperature of -10...60 °C
Linearity error	+/- 0.2...0.5 % of maximum value AI1, AI2, AI3 +/- 0.3 % AO1
Analogue output number	1
Analogue output type	Software-configurable current AO1 0...20 mA 800 Ohm 10 bits Software-configurable voltage AO1 0...10 V 470 Ohm 10 bits
Discrete output number	3
Discrete output type	Configurable relay logic R1A, R1B, R1C NO/NC 100000 cycles Configurable relay logic R2A, R2B NO 100000 cycles Logic LO
Minimum switching current	5 mA 24 V DC configurable relay logic
Maximum switching current	3 A 250 V AC resistive (cos phi = 1 R1 4 A 30 V DC resistive (cos phi = 1 R1 2 A 250 V AC inductive (cos phi = 0.4 R1, R2 2 A 30 V DC inductive (cos phi = 0.4 R1, R2 5 A 250 V AC resistive (cos phi = 1 R2 5 A 30 V DC resistive (cos phi = 1 R2
Discrete input number	7
Discrete input type	Programmable (sink/source) LI1...LI4 24...30 V DC level 1 PLC Programmable as pulse input 20 kpps LI5 24...30 V DC level 1 PLC Switch-configurable PTC probe LI6 24...30 V DC Safe torque off STO 24...30 V DC 1500 Ohm
Discrete input logic	Positive logic (source) LI1...LI6 < 5 V > 11 V Negative logic (sink) LI1...LI6 > 19 V < 13 V
Acceleration and deceleration ramps	S U CUS Deceleration ramp automatic stop DC injection Deceleration ramp adaptation Linear Ramp switching
Braking to standstill	By DC injection
Protection type	Input phase breaks drive Overcurrent between output phases and earth drive Overheating protection drive Short-circuit between motor phases drive Thermal protection drive
Communication port protocol	CANopen Modbus
Connector type	1 RJ45 Modbus/CANopen on front face
Physical interface	2-wire RS 485 Modbus
Transmission frame	RTU Modbus
Type of polarization	No impedance Modbus
Number of addresses	1...247 Modbus 1...127 CANopen
Method of access	Slave CANopen
Electromagnetic compatibility	1.2/50 µs - 8/20 µs surge immunity test level 3 IEC 61000-4-5 Electrical fast transient/burst immunity test level 4 IEC 61000-4-4

Electrostatic discharge immunity test level 3 IEC 61000-4-2
 Radiated radio-frequency electromagnetic field immunity test level 3 IEC 61000-4-3
 Conducted radio-frequency immunity test level 3 IEC 61000-4-6
 Voltage dips and interruptions immunity test IEC 61000-4-11

Width	1.77 in (45 mm)
Height	12.8 in (325 mm)
Depth	9.65 in (245 mm)
Product weight	5.29 lb(US) (2.4 kg)
Option card	Communication card CANopen daisy chain Communication card CANopen open style Communication card DeviceNet Communication card Ethernet/IP Communication card Profibus DP V1

Environment

standards	EN 55011 class A group 1 EN 61800-3 environments 1 category C2 EN 61800-3 environments 2 category C2 EN/IEC 61800-3 EN/IEC 61800-5-1
product certifications	CSA C-Tick GOST NOM 117 UL
marking	CE
pollution degree	2 EN/IEC 61800-5-1
IP degree of protection	IP20 EN/IEC 61800-5-1
vibration resistance	1 gn 13...200 Hz EN/IEC 60068-2-6 1.5 mm peak to peak 3...13 Hz EN/IEC 60068-2-6
shock resistance	15 gn 11 ms EN/IEC 60068-2-27
relative humidity	5...95 % without condensation IEC 60068-2-3 5...95 % without dripping water IEC 60068-2-3
ambient air temperature for operation	14...122 °F (-10...50 °C) without derating 122...140 °F (50...60 °C) with derating factor
ambient air temperature for storage	-13...158 °F (-25...70 °C)
operating altitude	<= 3280.84 ft (1000 m) without derating 3280.84...6561.68 ft (1000...2000 m) with current derating 1 % per 100 m
operating position	Vertical +/- 10 degree

Size A

Dimensions

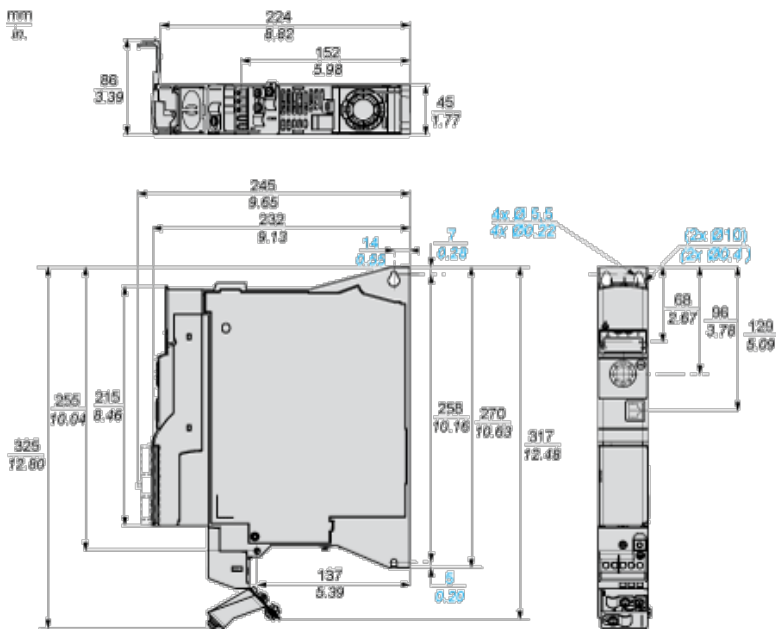

Mounting and Clearance

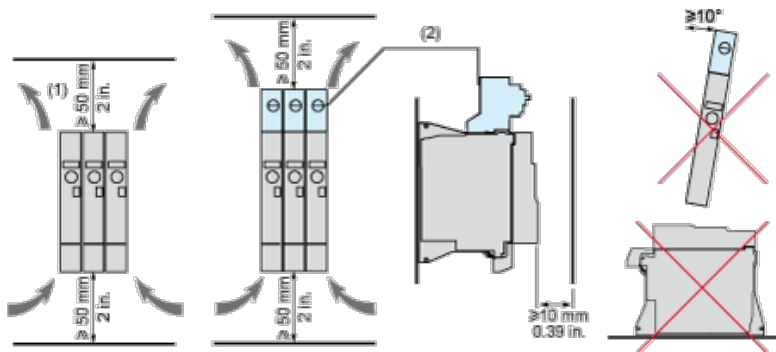

- (1) Minimum value corresponding to thermal constraints. A 150 mm clearance may help to connect the ground.
- (2) Optional GV2 circuit-breaker

Option: Protection Device, GV2 circuit-breaker

The drive is prepared to be equipped with an optional GV2 circuit-breaker.

The GV2 circuit-breaker is directly mounted on the drive. Mechanical and electrical link are made using the optional adapter. The options are supplied with detailed mounting instruction sheet.

NOTE: The product overall dimension, including GV2 adapter and EMC plate mounted, becomes 424 mm (16.7 in.)

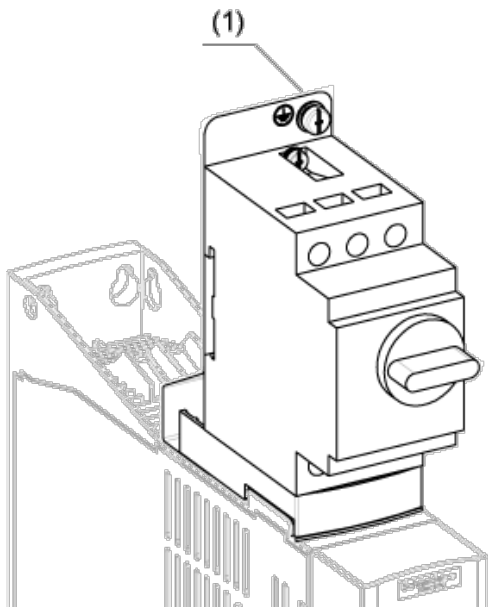

- (1) Ground screw (HS type 2 - 5x12)

Connection Diagrams

Single or Three-phase Power Supply - Diagram with Line Contactor

Connection diagrams conforming to standards EN 954-1 category 1 and IEC/EN 61508 capacity SIL1, stopping category 0 in accordance with standard IEC/EN 60204-1.

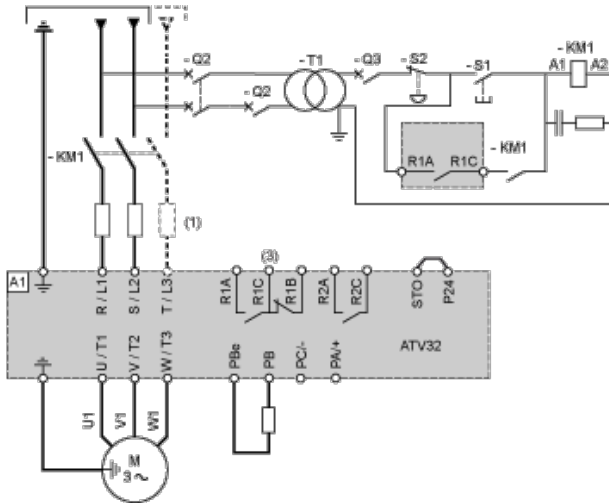

- (1) Line choke (if used)
- (3) Fault relay contacts, for remote signaling of drive status

Single or Three-phase Power Supply - Diagram with Switch Disconnect

Connection diagrams conforming to standards EN 954-1 category 1 and IEC/EN 61508 capacity SIL1, stopping category 0 in accordance with standard IEC/EN 60204-1.

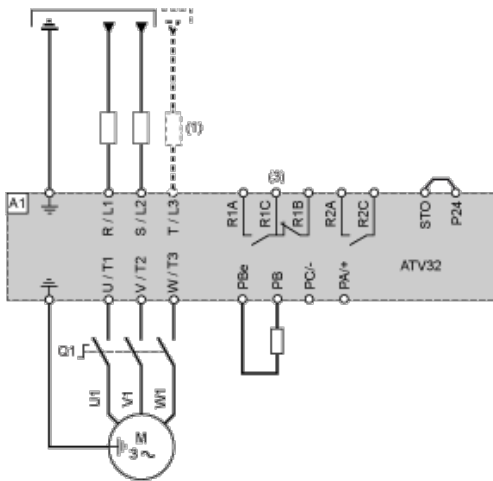

- (1) Line choke (if used)
- (3) Fault relay contacts, for remote signaling of drive status

Diagram with Preventa Safety Module (Safe Torque Off Function)

Connection diagrams conforming to standards EN 954-1 category 3 and IEC/EN 61508 capacity SIL2, stopping category 0 in accordance with standard IEC/EN 60204-1.

When the emergency stop is activated, the drive power supply is cut immediately and the motor stops in freewheel, according to category 0 of standard IEC/EN 60204-1.

A contact on the Preventa XPS AC module must be inserted in the brake control circuit to engage it safely when the STO (Safe Torque Off) safety function is activated.

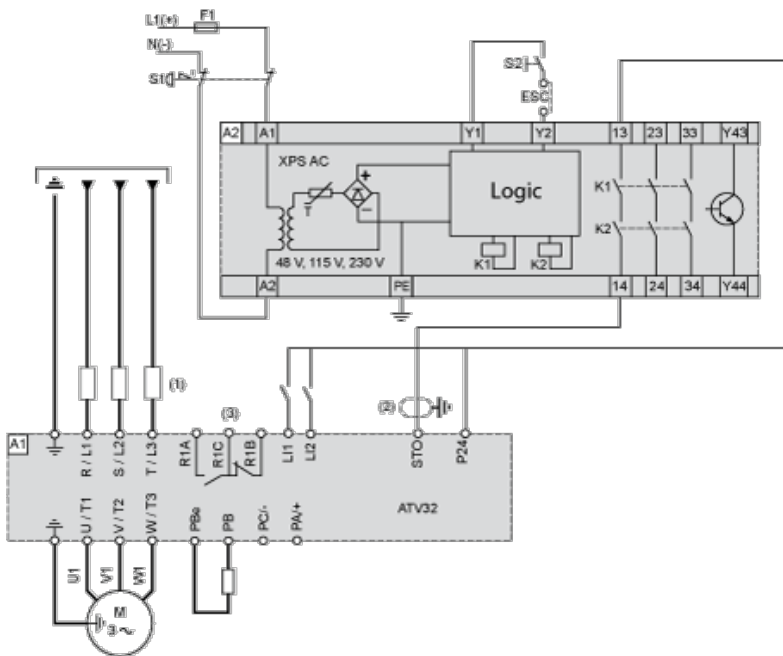

- (1) Line choke (if used)
- (2) It is essential to connect the shielding to the ground.
- (3) Fault relay contacts, for remote signaling of drive status

The STO safety function integrated into the product can be used to implement an "EMERGENCY STOP" (IEC 60204-1) for category 0 stops.

With an additional, approved EMERGENCY STOP module, it is also possible to implement category 1 stops.

STO function

The STO safety function is triggered via 2 redundant inputs. The circuits of the two inputs must be separate so that there are always two channels. The switching process must be simultaneous for both inputs (offset < 1 s).

The power stage is disabled and an error message is generated. The motor can no longer generate torque and coasts down without braking. A restart is possible after resetting the error message with a "Fault Reset".

The power stage is disabled and an error message is generated if only one of the two inputs is switched off or if the time offset is too great. This error message can only be reset by switching off the product.

Diagram without Preventa Safety Module

Connection diagrams conforming to standards EN 954-1 category 2 and IEC/EN 61508 capacity SIL1, stopping category 0 in accordance with standard IEC/EN 60204-1.

The connection diagram below is suitable for use with machines with a short freewheel stop time (machines with low inertia or high resistive torque).

When the emergency stop is activated, the drive power supply is cut immediately and the motor stops in freewheel, according to category 0 of standard IEC/EN 60204-1.

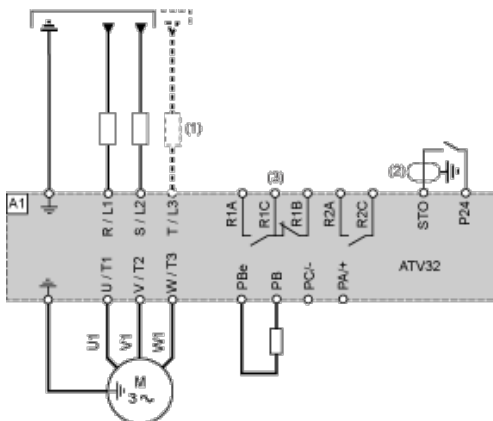

- (1) Line choke (if used)
- (2) It is essential to connect the shielding to the ground.
- (3) Fault relay contacts, for remote signaling of drive status

The STO safety function integrated into the product can be used to implement an "EMERGENCY STOP" (IEC 60204-1) for category 0 stops.

Control Connection Diagram in Source Mode

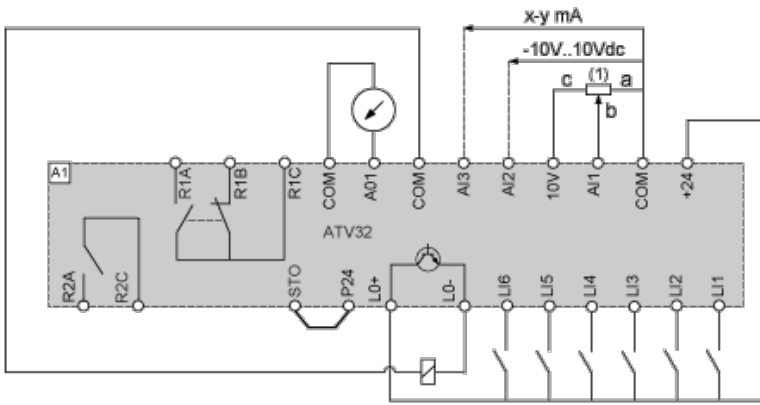

(1) Reference potentiometer SZ1RV1202 (2.2 kΩ) or similar (10 kΩ maximum)

Derating Curves

Derating curve for the nominal drive current (I_n) as a function of temperature and switching frequency.

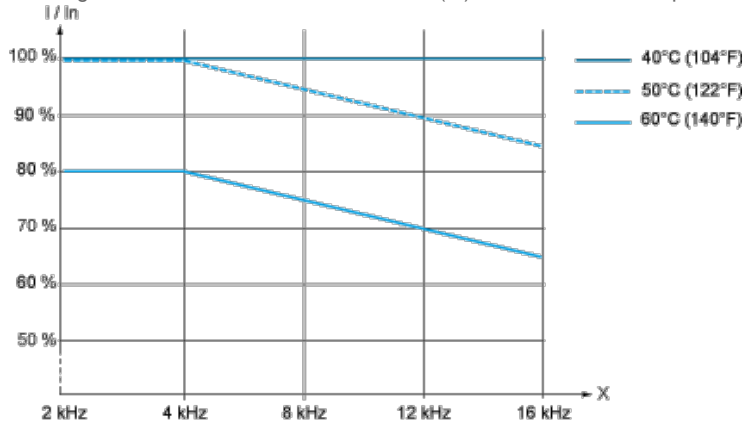

X Switching frequency

Above 4 kHz, the drive will reduce the switching frequency automatically in the event of an excessive temperature rise.

Sink / Source Switch Configuration (SW1)

The logic input switch (SW1) is used to adapt the operation of the logic inputs to the technology of the programmable controller outputs.

Switch SW1 set to "Source" position

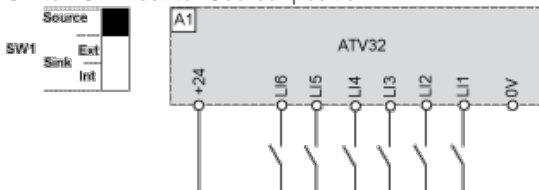

Switch SW1 set to "Source" position and use of an external power supply for the LIs

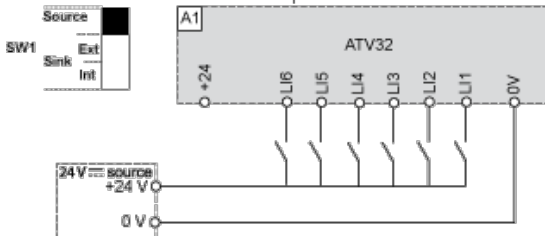

Switch SW1 set to "Sink Int" position

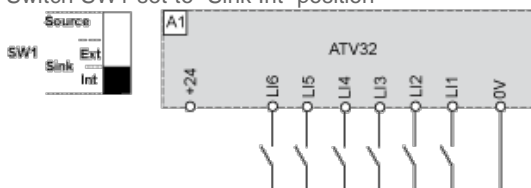

Switch SW1 set to "Sink Ext" position

