

**SPARE PARTS LIST**

| POS | QTY | TE / PN | RAYCHEM / PN | DESCRIPTION                              | GUIDELINE                          |
|-----|-----|---------|--------------|--|------------------------------------|
| 1   | 8   |         | 168927-000   | AD-3050-SEAL-CLAMP-ASSY                  | AD-3050 Replacement Clamp Assembly |
| 2   | 8   |         | 299155-000   | AD-3050-SEAL-8-KIT                       | AD-3050 Replacement Seals          |
| 3   | 1   |         | 2-744015-6   | IS412-94165, AD-3050 SEAL TEST EQUIPMENT | Instruction Sheet                  |

**OPTION**

|   |   |            |  |                   |                                  |
|---|---|------------|--|-------------------|----------------------------------|
| 4 | 1 | 4-529533-7 |  | TIMER UPGRADE KIT | Integration of a pneumatic Timer |
|---|---|------------|--|-------------------|----------------------------------|

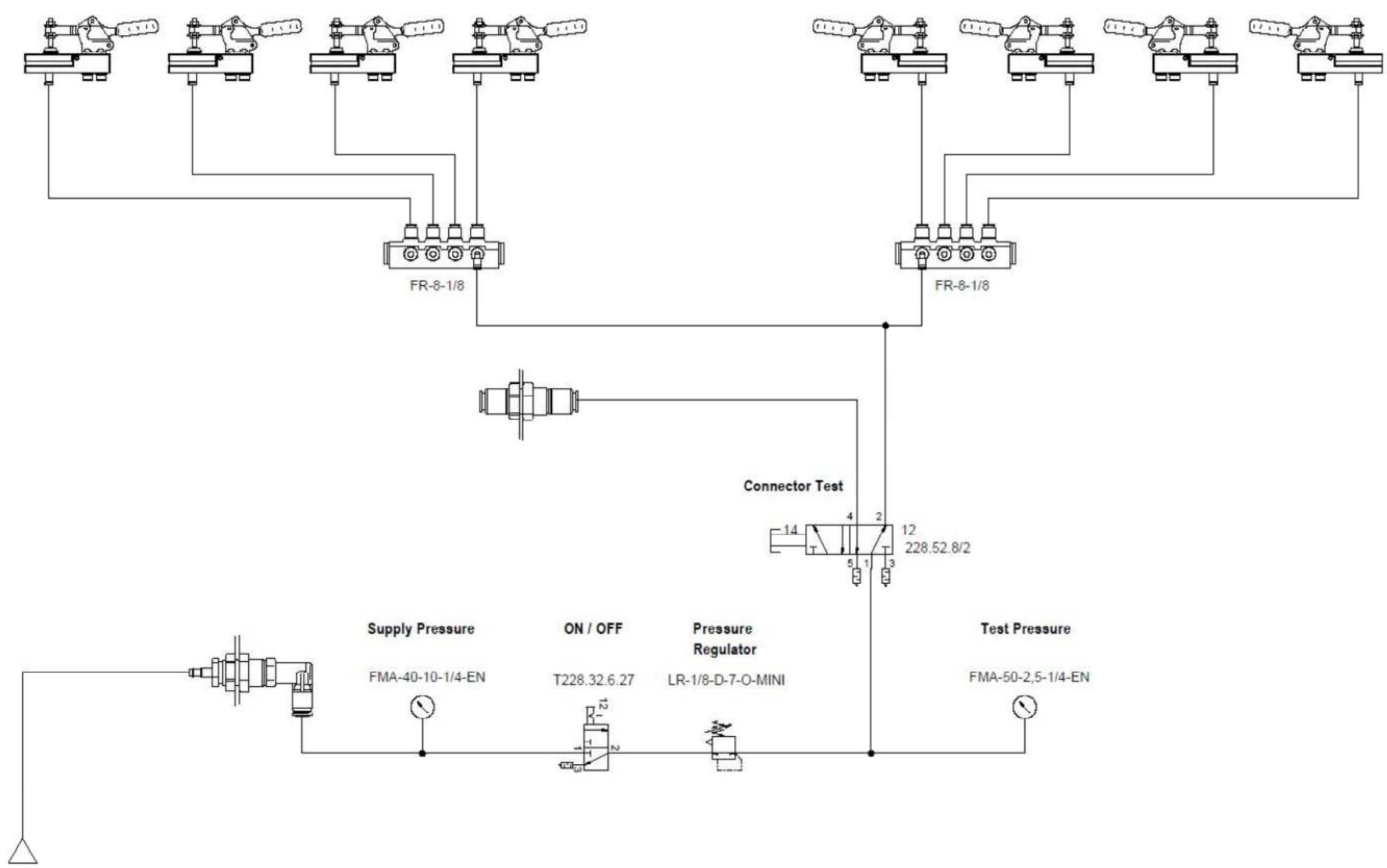

|   |  |   |                                   |  |                           |
|---|--|---|-----------------------------------|--|---------------------------|
| <b>THIS DRAWING IS A CONTROLLED DOCUMENT.</b> |  | DWN: <b>G.Miles</b> 04OCT2012<br>CHK: <b>C.Nitsch</b> 04OCT2012<br>APP'D: <b>C.Nitsch</b> 04OCT2012<br>PRODUCT SPEC | TE Connectivity                   | NAME<br><b>AD-3050 SEAL TEST EQUIPMENT</b><br><b>RAYCHEM Seal Test Equipment, C82893-000</b> |                           |
| DIMENSIONS:<br>mm<br>                         | TOLERANCES UNLESS OTHERWISE SPECIFIED:<br>0 PLC ±<br>3 PLC ±<br>3 PLC ±<br>3 PLC ±<br>ANGLES ± | APPLICATION SPEC<br>Gewicht / Weight in Kg<br><b>4</b>  |                                   | SIZE<br><b>A2</b>  | CASE CODE<br><b>00779</b> |
| MATERIAL FINISH                               |  |   | RESTRICTED TO<br><b>1201563-2</b> |  | SCALE<br><b>1:1</b>       |
| CUSTOMER DRAWING                              |  |   | SHEET<br><b>1</b>                 | of<br><b>2</b>   | REV<br><b>D</b>           |