

LTC4071EDDB: Li-Ion / Polymer Shunt Battery Charger System with Low Battery Disconnect

DESCRIPTION

Demonstration Circuit DC1702A is a Li-Ion/Polymer Shunt Battery Charger system with Low Battery Disconnect featuring the LTC[®]4071EDDB.

PERFORMANCE SUMMARY Specifications are at T_a = 25°C

SYMBOL	PARAMETER	CONDITIONS	MIN	TYP	MAX	UNITS
V _{BUS}	Input voltage	R _{LIMIT} = 169Ω	10	12	16	V
V(BAT)	Battery Float Voltage	'VFLOAT' jumper on 4.1V, Constant Voltage Mode. T _{NTC} = 25°C	4.059		4.141	V
I(BAT)	Battery Charge Current	Constant Current Mode, V _{in} = 12V, V _{CC} = 3.8V		49.7		mA

QUICK START PROCEDURE

Refer to Figure 1 for the proper measurement equipment setup and jumper settings and follow the procedure below.

NOTE. When measuring the input or output voltage ripple, care must be taken to avoid a long ground lead on the oscilloscope probe. Measure the input or output voltage ripple by touching the probe tip directly across the VIN or V_{CC} and GND terminals. See Figure 2 for proper scope probe technique.

- Set PS1 = 12V, PS2 = 3.6V, "VFLOAT" (JP2) to 4.1V. Observe I(VIN) (AM1) and I(BAT) (AM2). The shunt voltage of the LTC4071 is set to 4.1V, and the battery voltage is set to 3.6V. The LTC4071 is only shunting its quiescent current, ≈500nA, so all of the current flowing through R1 is going to charge the battery. $(12 - 3.6)/499 = 16.8\text{mA}$.
- Increase PS2 until HBO LED is lit. Observe V(BAT) (VM2). The HBO LED will activate when the battery is nearly fully charged or at ≈ V_{float} – 50mV.
- Continue to increase PS2, and observe AM1 and AM2. At the programmed float voltage for the LTC4071, AM2 will go to 0A. The LTC4071 is now shunting all of the current flowing through R1, to ground. The float voltage on the LTC4071 has a tolerance of 1%.
- Disconnect PS1 and decrease PS2 until V_{CC} (VM3) goes to less than 100mV. Observe V(BAT) (VM2). This is the low battery voltage disconnect. When the battery voltage reaches the low battery disconnect threshold (LBO) (2.7V or 3.2V), an internal switch disconnects BAT from V_{CC}. The BAT pin current when disconnected is less than 0.1nA. However the PCB and other components may increase the total battery leakage to 2~10nA. Measuring this leakage current requires great care.
- Increase PS2 by 0.3V. Reconnect PS1 and set to the same voltage as PS2. Slowly increase PS1

until V_{CC} snaps down to $\approx V(\text{BAT})$. This is the Low Battery Reconnect. Applying power to V_{CC} charges the battery via the body diode of the internal V_{CC} to BAT MOSFET switch. When the battery has recharged approximately 0.3V, and enough voltage is applied to V_{CC} , the switch will reconnect. The reconnect voltage (at V_{CC}) is approximately $V(\text{LBO}) + 0.3V + 0.6V$. So with LBO set to 3.2V, reconnect will occur at $V_{CC} \approx 4.1V$. And because V_{CC} is connected through R1 to PS1, reconnection causes V_{CC} to snap down to the $V(\text{BAT})$.

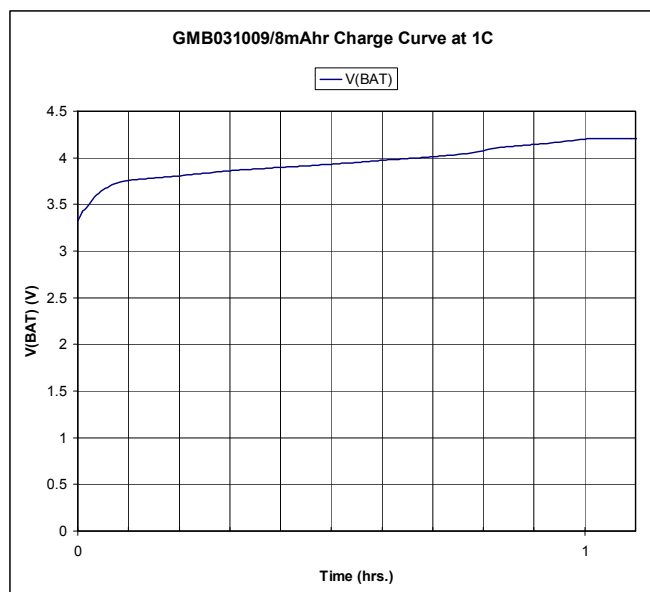

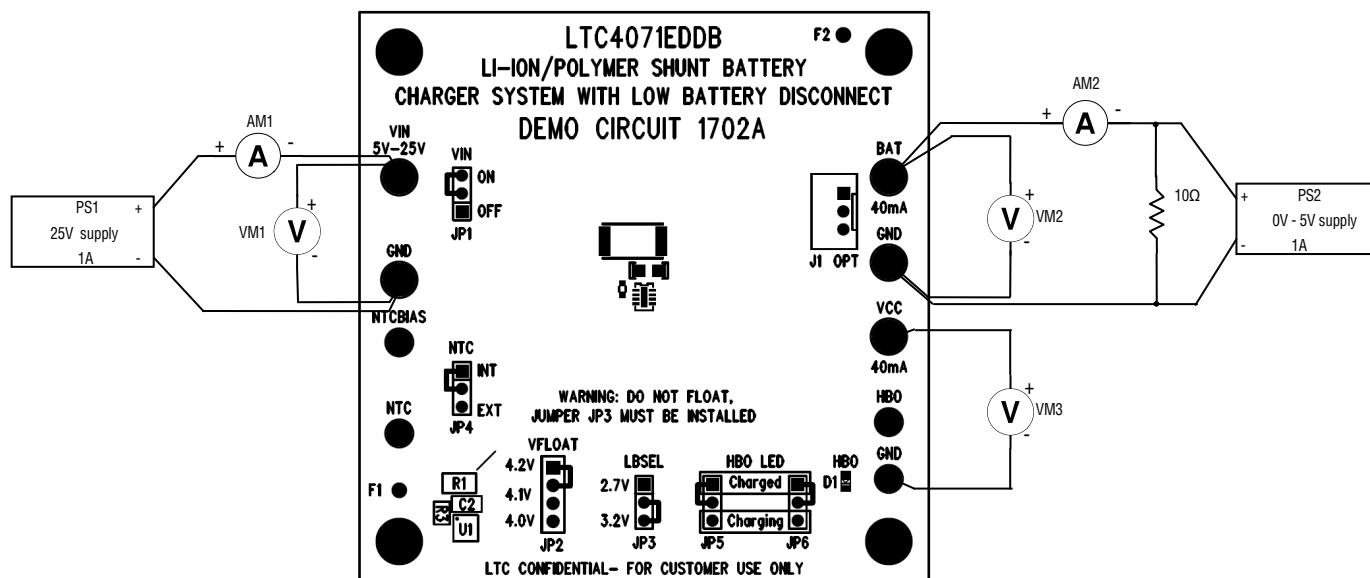

Note: All connections from equipment should be Kelvin connected directly to the board pins which they are connected on this diagram and any input or output leads should be twisted pair.

Figure 1. Proper Measurement Equipment Setup for DC1702A

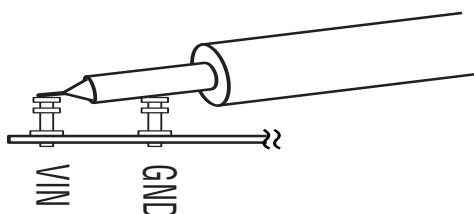

Figure 2. Measuring Input or Output Ripple

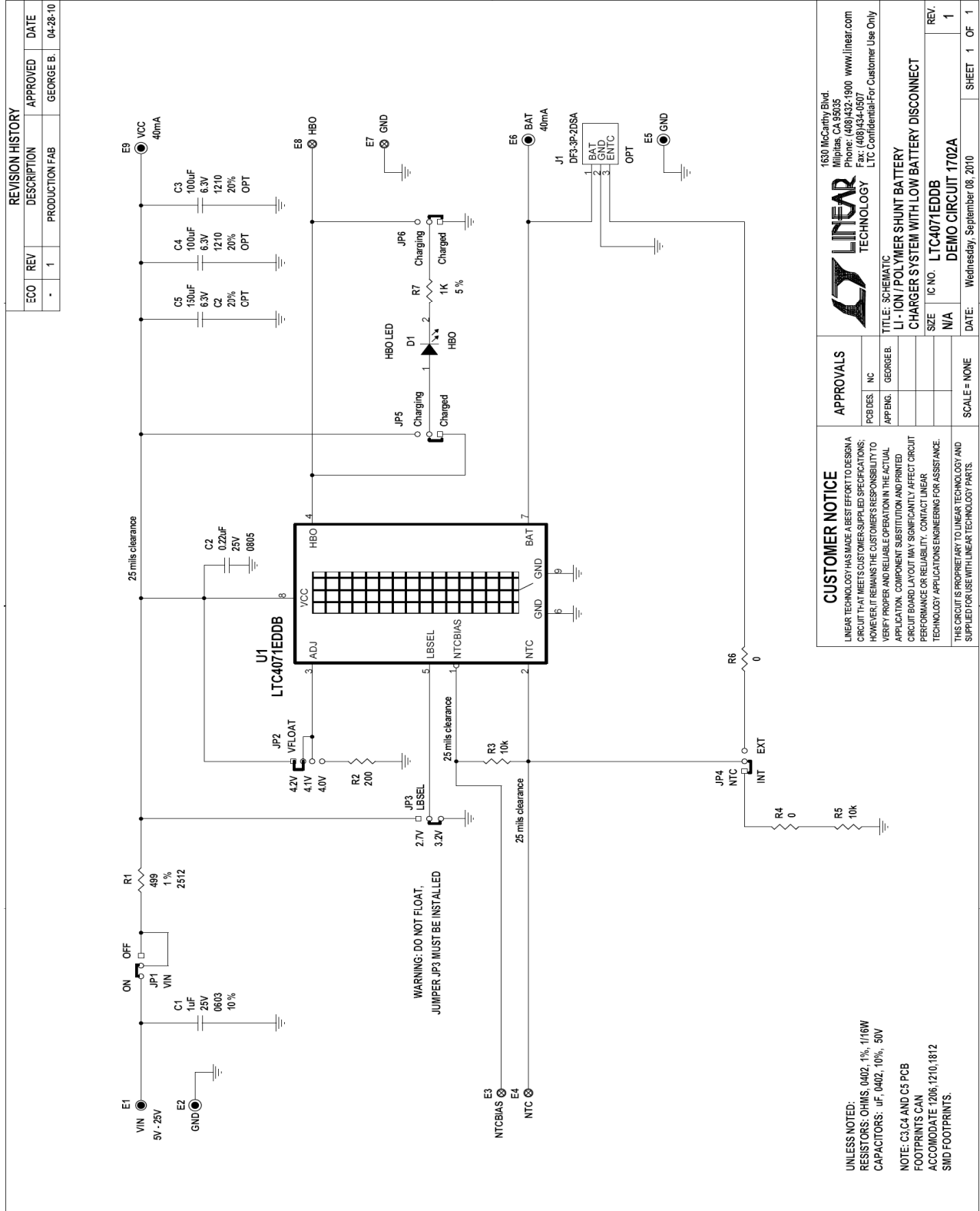

Figure 3. Schematic

	Qty	Reference	Part Description	Manufacturer / Part #
REQUIRED CIRCUIT COMPONENTS:				
1	1	C1	CAP, CHIP, X5R, 1 μ F, \pm 20%, 25V, 0603	TDK, C1608X5R1E105K
2	1	C2	CAP, CHIP, X7R, 0.22 μ F, \pm 10%, 50V, 0805	AVX, 08055C224KAT2A
3	1	R1	RES, CHIP, 499 Ω , \pm 1%, 1W, 2512	VISHAY, CRCW2512499RFKED
4	1	R2	RES, CHIP, 200 Ω , \pm 1%, 1/16W, 0402	VISHAY, CRCW0402200RFKED
5	2	R3, R5	RES, CHIP, 10k Ω , \pm 1%, 1/16W, 0402	VISHAY, CRCW040210K0FKED
6	2	R4, R6	RES, CHIP, 0 Ω jumper, 1/16W, 0402	VISHAY, CRCW04020000Z0ED
7	1	R7	RES, CHIP, 1k Ω , \pm 5%, 1/16W, 0402	VISHAY, CRCW04021K00JNED
8	1	U1	IC, SMT, LI-ION/POLYMER SHUNT BATTERY CHARGER SYSTEM WITH LOW BATTERY DISCONNECT	LINEAR TECH., LTC4071EDDB
ADDITIONAL DEMO BOARD CIRCUIT COMPONENTS:				
1	0	C3-OPT, C4-OPT	CAP, CHIP, X5R, 100 μ F, \pm 20%, 6.3V, 1210	TDK, C3225X5R0J107M
2	0	C5-OPT	CAP, POSCAP, 150 μ F, \pm 20%, 6.3V, C2 case	SANYO, 6TPE150MIC2
3	1	D1	DIODE, LED, GREEN, 0603	LITE-ON, LTST-C190KGKT
HARDWARE FOR DEMO BOARD ONLY:				
1	4	E1-2, E5-6	TURRET, 0.09 DIA	MILL-MAX, 2501-2-00-80-00-00-07-0
2	4	E3-4, E7-8	TURRET, 0.061 DIA	MILL-MAX, 2308-2-00-80-00-00-07-0
3	0	J1-OPT	CONN, 3 Pin Polarized	HIROSE, DF3-3P-2DSA
4	5	JP1, JP3-6	3 Pin Jumper, 2mm	SAMTEC, TMM-103-02-L-S
5	1	JP2	4 Pin Jumper, 2mm	SAMTEC, TMM-104-02-L-S
6	6	JP1-6	SHUNT, 2mm	SAMTEC, 2SN-KB-G
7	4		STAND-OFF, NYLON, 0.375"	KEYSTONE, 8832

Figure 4. Bill of Materials