

PART NAME: KNOB SCALE: 1:1 DATE: 7/15/97 DR. BY HD

DAVIES MOLDING COMPANY  
CAROL STREAM, ILLINOIS 60188

P/N 1940BG

THIS DRAWING IS THE PROPERTY OF DAVIES MOLDING COMPANY, IS SUBMITTED SOLELY AS A DESIGN OR ENGINEERING PROJECT. WE ACCEPT NO RESPONSIBILITY WHATSOEVER FOR THE PRACTICAL APPLICATION OF THE PIECES MADE TO THIS DESIGN.

BASE PART	1940-01
INLAY	I0566(SS)
SET SCREW	I0545

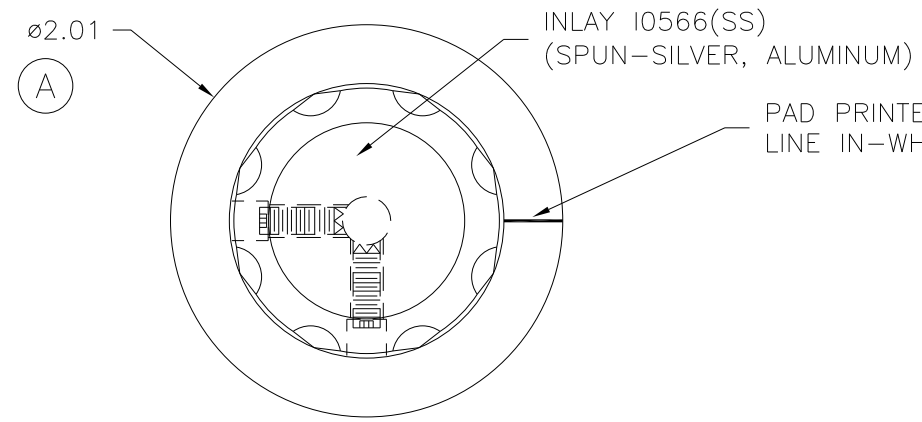

$\frac{3}{16} \times \frac{3}{16}$  MACHINE C'BORE  
USE #28 DRILL (ø0.140), #8-32 TAP.  
#8-32 THREAD X 7/16 LG. CUP POINTED,  
SOCKET TYPE, SET SCREW I0545 (2)

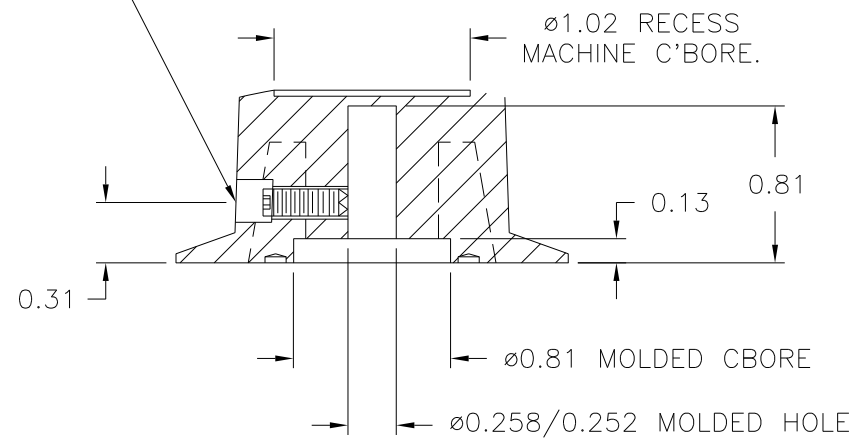
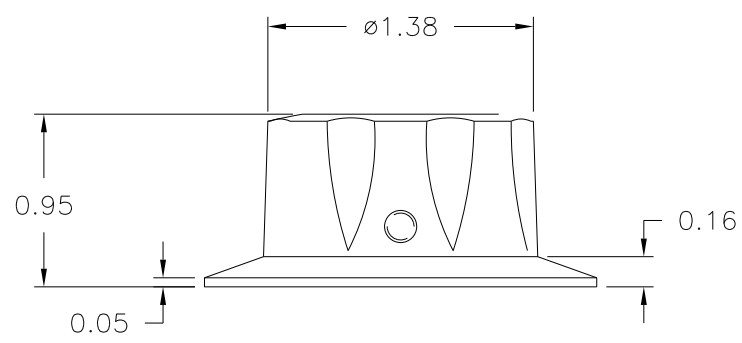

SECTION A-A

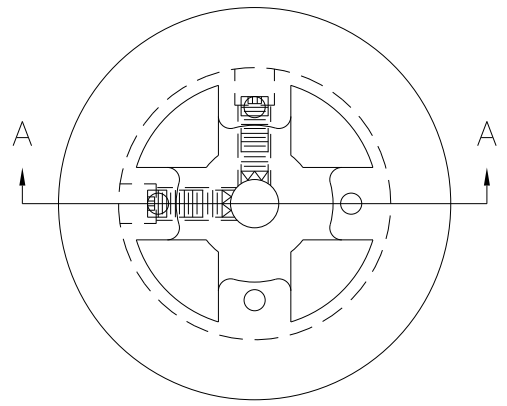

(B)  
MATERIAL: 04311 PHENOLIC (B41)  
COLOR: BLACK

TOLERANCES: UNLESS OTHERWISE SPECIFIED	DO NOT SCALE DRAWING	B	WAS #2511 PHENOLIC (B11)	JAM	7/16/08
DECIMALS: X.XXX ± .005 X.XX ± .015	MM: X.XX ± 0.15MM X.X ± 0.4MM	-	UPDATED/HAD TOOLBOX	ST	12/5/00
FRACTIONS ± 1/64	ANG. ± 1°	A	WAS ø2.00	TL	9/24/99
CHANGES					