

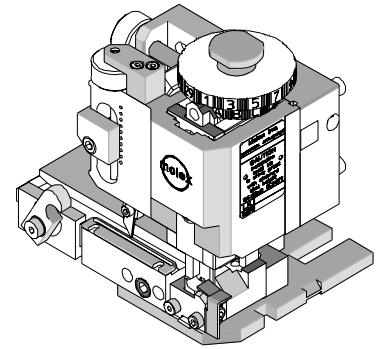

## FineAdjust Applicator Specification Sheet Part No. 63860-1000



### FEATURES

- Quick punch removal with the push of a button for fast and easy tooling change
- Applicator designed to industry standard mounting and shut height 135.80mm (5.346")
- Quick set-up time; plus the crimp height, track and feed adjustments can be set without removing the applicator from the press
- Fine adjustment allows users to achieve target with little effort by adjusting in increments of 0.15mm (.0006") for conductor crimp height and .063mm (.0025") for insulation height
- Independent adjustment rings allow users to quickly adjust the conductor or insulation crimp height without affecting each other
- Directly adapts to most automatic wire processing machines

### SCOPE

Products: Mini-Fit Jr.™ Crimp Terminal 18-24 AWG with large insulation OD's.

Terminal Series No.	Terminal Order No.				Wire Size		★ Insulation Diameter		Strip Length	
					AWG	mm <sup>2</sup>	mm	In.	mm	In.
5556	39-00-0038	39-00-0153	39-00-0200	39-00-0419	18-24	0.80-0.20	2.15-3.10	.085-.122	3.00-3.50	.118-.138
	39-00-0055	39-00-0163	39-00-0207	39-00-0425						
	39-00-0059	39-00-0169	39-00-0213	39-00-0428						
	39-00-0073	39-00-0175	39-00-0405	39-00-0436						
	39-00-0108	39-00-0181	39-00-0407	39-00-0440						
	39-00-0114	39-00-0194	39-00-0410	40-13-0851						
5558	39-00-0040	39-00-0120	39-00-0420	39-00-0437	18-24	0.80-0.20	2.15-3.10	.085-.122	3.00-3.50	.118-.138
	39-00-0053	39-00-0126	39-00-0426	40-01-0853						
	39-00-0061	39-00-0219	39-00-0427	40-13-0853						
	39-00-0075	39-00-0411	39-00-0430	98-00-0174						
30490	30490-0002	30490-1002	30490-2002		18-24	0.80-0.20	2.15-3.10	.085-.122	3.00-3.50	.118-.138
44476	44476-1111	44476-1211			18-20	0.80-0.50	2.15-3.10	.085-.122	3.00-3.50	.118-.138
44478	44478-1111	44478-1211			18-20	0.80-0.50	2.15-3.10	.085-.122	3.00-3.50	.118-.138
44485	44485-1211	44485-1311	44485-1411		18-24	0.80-0.20	2.15-3.10	.085-.122	3.00-3.50	.118-.138
45750	45750-1111	45750-1211			18-20	0.80-0.50	2.05-2.95	.081-.116	3.00-3.50	.118-.138
46012	46012-1111	46012-1211			18-20	0.80-0.50	2.05-2.95	.081-.116	3.00-3.50	.118-.138
46018	46018-1541				18-20	0.80-0.50	2.05-2.95	.081-.116	3.00-3.50	.118-.138
46083	46083-1111	46083-1121	46083-1211	46083-1221	18-20	0.80-0.50	2.05-2.95	.081-.116	3.00-3.50	.118-.138
46098	46098-1541				18-20	0.80-0.50	2.05-2.95	.081-.116	3.00-3.50	.118-.138
<p>★ This Applicator will crimp the above terminals and wires.            However it provides optimum A-620 Class 2 crimps for 18-20 AWG wire            with insulation O.D. 2.50-2.95mm (example UL1015).            Applicator 63860-1400 should be used for insulation O.D. 1.65-2.05mm (example UL1007).</p>										

### DEFINITION OF TERMS

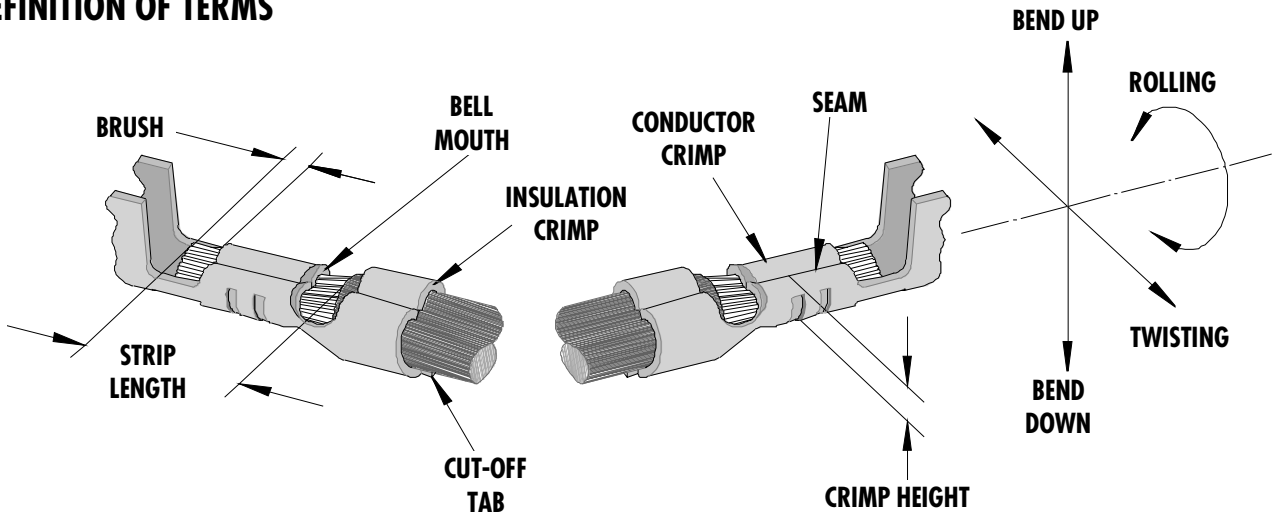

The above terminal drawing is a generic terminal representation. It is not an image of a terminal listed in the scope.

### CRIMP SPECIFICATION

Terminal Series No.	Bell mouth		Cut-off Tab Max.		Conductor Brush	
	mm	In.	mm	In.	mm	In.
5556	0.20-0.50	.008-.020	0.30	.012	0.00-1.00	.000-.039
5558	0.20-0.50	.008-.020	0.30	.012	0.00-1.00	.000-.039
30490	0.20-0.50	.008-.020	0.30	.012	0.00-1.00	.000-.039
44476	0.20-0.50	.008-.020	0.30	.012	0.00-1.00	.000-.039
44478	0.20-0.50	.008-.020	0.30	.012	0.00-1.00	.000-.039
44485	0.20-0.50	.008-.020	0.30	.012	0.00-1.00	.000-.039
45750	0.20-0.50	.008-.020	0.30	.012	0.00-1.00	.000-.039
46012	0.20-0.50	.008-.020	0.30	.012	0.00-1.00	.000-.039
46018	0.20-0.50	.008-.020	0.30	.012	0.00-1.00	.000-.039
46083	0.20-0.50	.008-.020	0.30	.012	0.00-1.00	.000-.039
46098	0.20-0.50	.008-.020	0.30	.012	0.00-1.00	.000-.039

Terminal Series No.	Bend up	Bend down	Twist	Roll	Punch Width (Ref)			
					Conductor		Insulation	
	Degree		Degree		mm	In.	mm	In.
5556	5	2	5	15	1.60	.063	3.20	.126
5558	5	2	5	15	1.60	.063	3.20	.126
30490	5	2	5	15	1.60	.063	3.20	.126
44476	5	2	5	15	1.60	.063	3.20	.126
44478	5	2	5	15	1.60	.063	3.20	.126
44485	5	2	5	15	1.60	.063	3.20	.126
45750	5	2	5	15	1.60	.063	3.20	.126
46012	5	2	5	15	1.60	.063	3.20	.126
46018	5	2	5	15	1.60	.063	3.20	.126
46083	5	2	5	15	1.60	.063	3.20	.126
46098	5	2	5	15	1.60	.063	3.20	.126

**Seam**  
Seam shall not be open  
And no wire allowed out  
of the crimping area

After crimping, the crimp profiles should measure the following:

Terminal Series No.	Wire Size		Conductor				Pull Force Min.	
			Crimp Height		Crimp Width (Ref)			
	AWG	mm <sup>2</sup>	mm	In.	mm	In.	N	Lb.
5556	18	0.80	0.97-1.07	.038-.042	1.68	.066	88.0	19.8
5556	20	0.50	0.95-1.04	.037-.041	1.66	.065	58.7	13.2
5556	22	0.35	0.85-0.94	.033-.037	1.65	.065	39.1	8.8
5556	24	0.20	0.79-0.87	.031-.034	1.63	.064	29.3	6.6
5558	18	0.80	0.97-1.07	.038-.042	1.68	.066	88.0	19.8
5558	20	0.50	0.95-1.04	.037-.041	1.66	.065	58.7	13.2
5558	22	0.35	0.85-0.94	.033-.037	1.65	.065	39.1	8.8
5558	24	0.20	0.79-0.87	.031-.034	1.63	.064	29.3	6.6
30490	18	0.80	0.97-1.07	.038-.042	1.68	.066	88.0	19.8
30490	20	0.50	0.95-1.04	.037-.041	1.66	.065	58.7	13.2
30490	22	0.35	0.85-0.94	.033-.037	1.65	.065	39.1	8.8
30490	24	0.20	0.79-0.87	.031-.034	1.63	.064	29.3	6.6
44476	18	0.80	0.97-1.07	.038-.042	1.68	.066	68.4	15.4
44476	20	0.50	0.95-1.04	.037-.041	1.66	.065	58.7	13.2
44478	18	0.80	0.97-1.07	.038-.042	1.68	.066	68.4	15.4
44478	20	0.50	0.95-1.04	.037-.041	1.66	.065	58.7	13.2
44485	18	0.80	0.97-1.07	.038-.042	1.68	.066	88.0	19.8
44485	20	0.50	0.95-1.04	.037-.041	1.66	.065	58.7	13.2
44485	22	0.35	0.85-0.94	.033-.037	1.65	.065	39.1	8.8
44485	24	0.20	0.79-0.87	.031-.034	1.63	.064	29.3	6.6
45750	18	0.80	0.97-1.07	.038-.042	1.68	.066	68.4	15.4
45750	20	0.50	0.84-0.94	.033-.037	1.66	.065	58.7	13.2
46012	18	0.80	0.97-1.07	.038-.042	1.68	.066	68.4	15.4
46012	20	0.50	0.84-0.94	.033-.037	1.66	.065	58.7	13.2
46018	18	0.80	0.97-1.07	.038-.042	1.68	.066	68.4	15.4
46018	20	0.50	0.84-0.94	.033-.037	1.66	.065	58.7	13.2
46083	18	0.80	0.97-1.07	.038-.042	1.68	.066	68.4	15.4
46083	20	0.50	0.84-0.94	.033-.037	1.66	.065	58.7	13.2
46098	18	0.80	0.97-1.07	.038-.042	1.68	.066	68.4	15.4
46098	20	0.50	0.84-0.94	.033-.037	1.66	.065	58.7	13.2

**🔧 Tool Qualification Notes:**

1. Pull Force should be measured with no influence from the insulation crimp.
2. The above specifications are guidelines to an optimum crimp.

**PARTS LIST**

<b>FineAdjust Applicator 63860-1000</b>				
<b>Item</b>	<b>Order No</b>	<b>Engineering No.</b>	<b>Description</b>	<b>Quantity</b>
<b>Perishable Tooling</b>				
	63860-1070	63860-1070	Tool Kit (All "Y" Items)	REF
1	63444-1609	63444-1609	Conductor Punch	1 Y
2	63445-1646	63445-1646	Conductor Anvil	1 Y
3	63446-3208	63446-3208	Insulation Punch	1 Y
4	63445-3211	63445-3211	Insulation Anvil	1 Y
5	63443-0002	63443-0002	Cut-Off Plunger Front	1 Y
6	63443-0012	63443-0012	Plunger Retainer Front	1 Y
<b>Other Components</b>				
7	11-24-1067	4996-4	Cut-off Plunger Spring	1
8	11-40-4039	8302-5	Plunger Striker Front	1
9	63443-0021	63443-0021	Lower Tooling Key	1
10	63443-6003	63443-6003	Rear Cover	1
11	11-18-4083	60707-8	Front Cover	1
12	63443-2408	63443-2408	Anvil Mount	1
13	63443-4018	63443-4018	Wire Stop	1
14	63443-0009	63443-0009	Scrap Chute Front	1
<b>Frame</b>				
15	63800-4901	63800-4901	Top	1
16	63801-3281	63801-3281	Base	1
17	63801-4650	63801-4650	Track	1
<b>Hardware</b>				
18	N/A	N/A	M3 by 6Lg. SHCS	2**
19	N/A	N/A	M4 by 6Lg. SHCS	1**
20	N/A	N/A	M4 by 12Lg. BHCS	2**
21	N/A	N/A	M4 by 16Lg SHCS	1**
22	N/A	N/A	M4 by 20Lg. SHCS	1**
23	N/A	N/A	M4 by 50Lg. SHCS	1**
24	N/A	N/A	3MM by 6Lg. Roll Pin	1**
25	N/A	N/A	#10-32 by 1/4"Lg. BHCS	1**
** Available from an industrial supply company such as MSC (1-800-645-7270).				

# Assembly Drawing

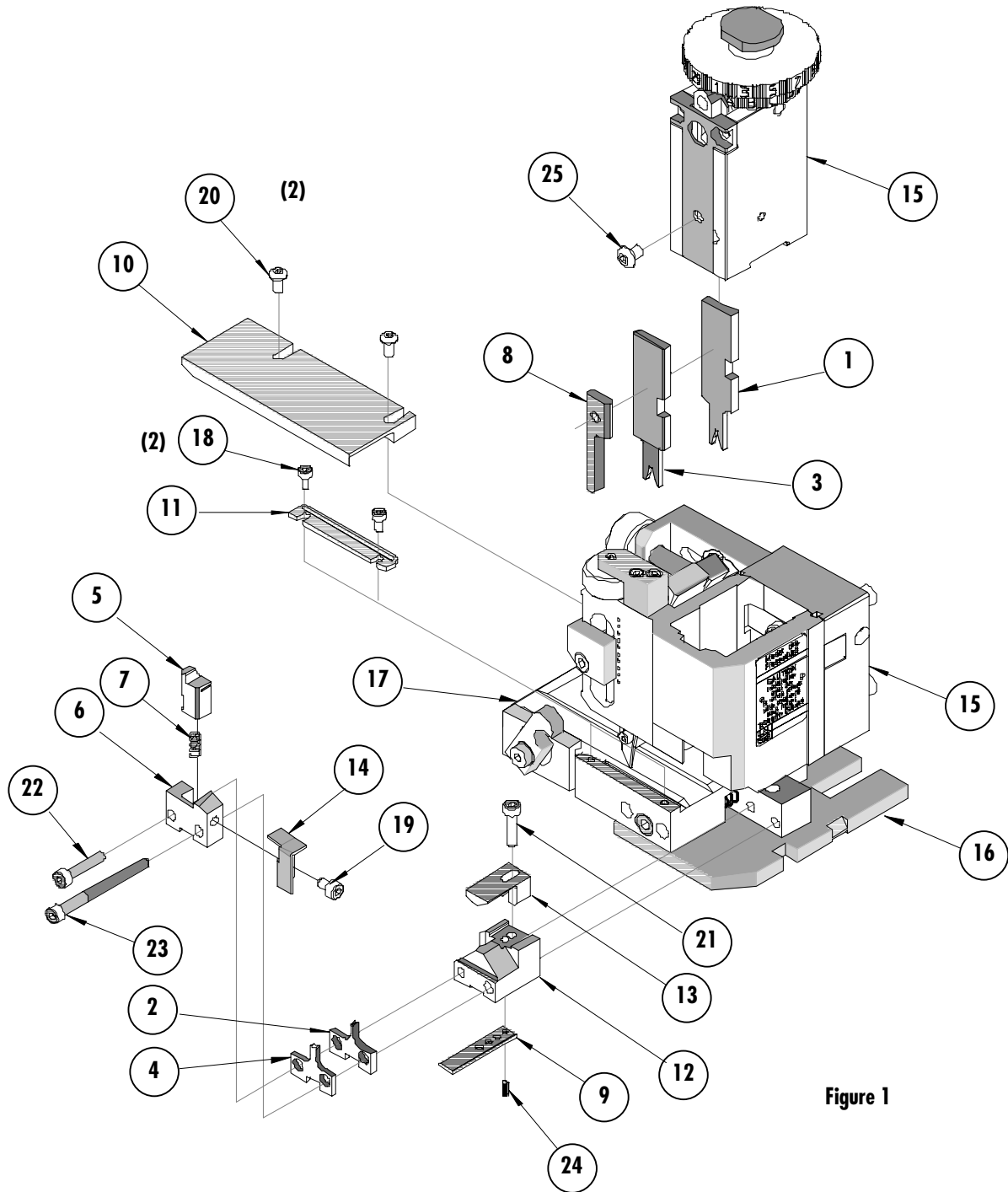

Figure 1

## NOTES

1. Molex recommends an extra perishable tooling kit be maintained at your facility.
2. Verify tooling alignment by manually cycling the press and Applicator before crimping under power. Check that all screws are tight.
3. Slugs, Terminals, Dirt and Oil should be kept clear of work area.
4. Wear safety glasses at all times.
5. For recommended maintenance refer to the FineAdjust Manual.

**CAUTION:** This applicator should only be used in a press with a shut height of 135.80 mm (5.346"). Tooling damage could result at a lower setting.

**CAUTION:** To prevent injury never operate this Applicator without the guards supplied with the press or wire-processing machine in place. Reference the press or wire processing manufacturer's instruction manual.

**CAUTION:** Molex crimp specifications are valid only when used with Molex terminals, applicators and tooling.

**Americas Headquarters**

Lisle, Illinois 60532 U.S.A.  
1-800-78MOLEX  
amerinfo@molex.com

**Far East North Headquarters**

Yamato, Kanagawa, Japan  
81-462-65-2324  
feninfo@molex.com

**Far East South Headquarters**

Jurong, Singapore  
65-6-268-6868  
fesinfo@molex.com

**European Headquarters**

Munich, Germany  
49-89-413092-0  
eurinfo@molex.com

**Corporate Headquarters**

2222 Wellington Ct.  
Lisle, IL 60532 U.S.A.  
630-969-4550  
Fax: 630-969-1352

Visit our Web site at <http://www.molex.com>