

LOC
HB

DIST
-

REVISIONS

P	LTR	DESCRIPTION	DATE	DWN	APVD
E		1.UPDATE TE LOGO&VDE LOGO 2.ADD LINE IDENTIFICATION 3.TERMINALS TOLERANCE CLARIFICATION4.VENT HOLE CHANGE	ECO-12-005726	06-APR-12	D.L BH.Y
F		CHANGE THE VENT HOLE SHAPE FROM RECTANGLE TO CIRCLE ONE	ECO-13-015347	16-DEC-13	XL,Y B,F

D

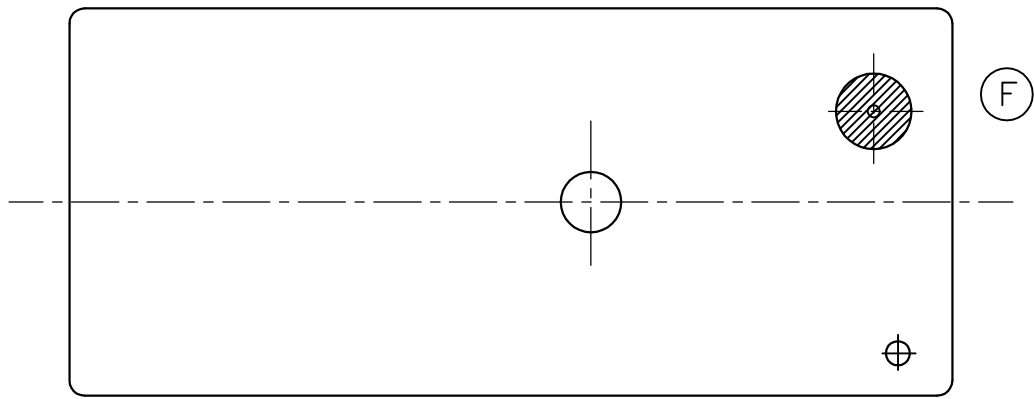

C

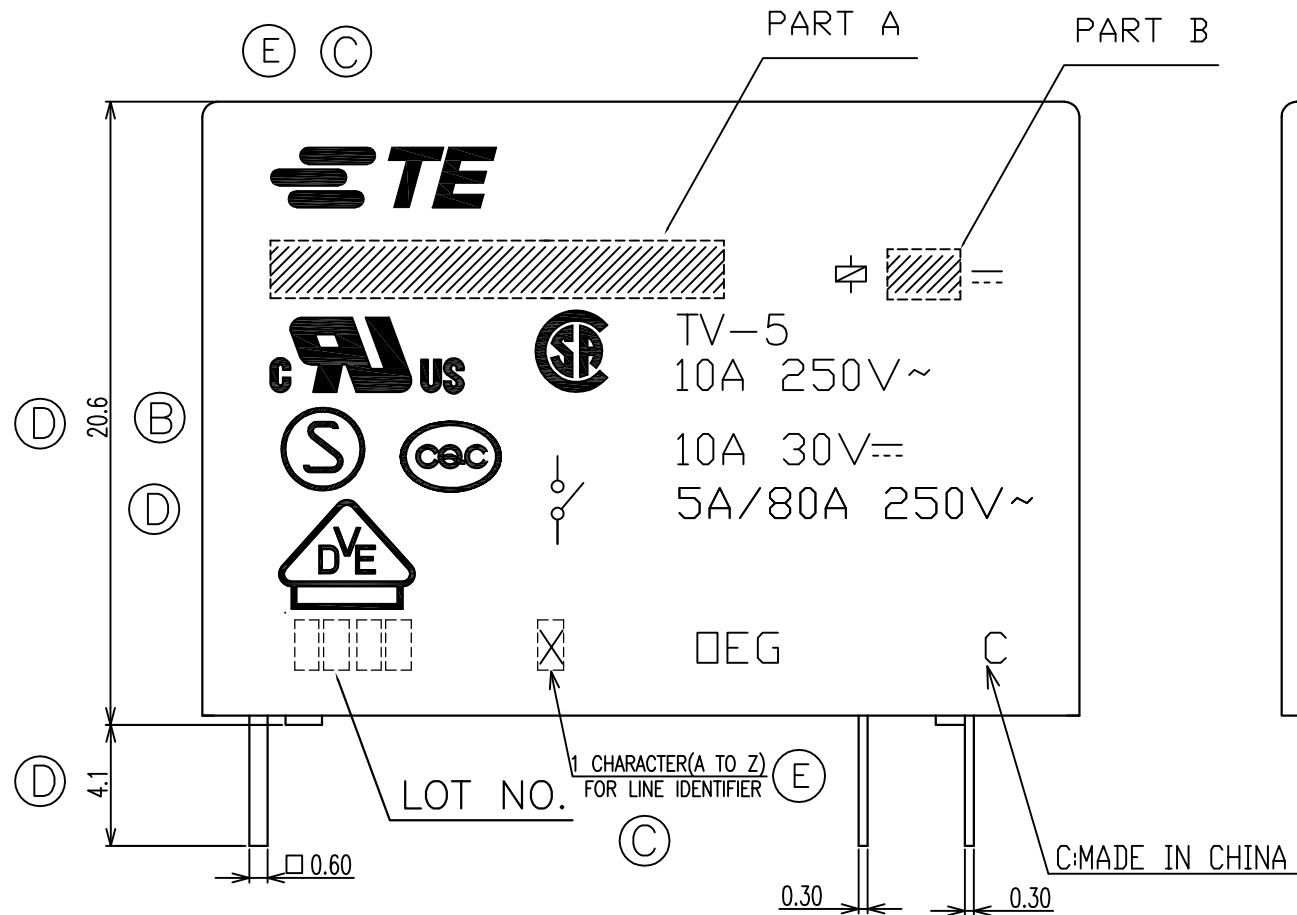

B

A

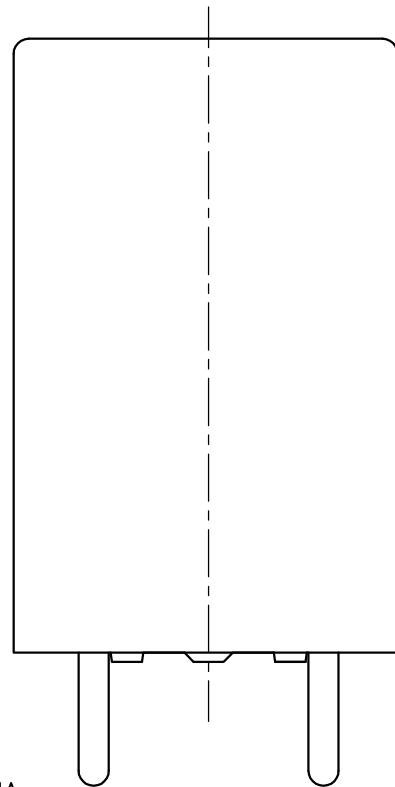

CONNECTION DIAGRAM
(BOTTOM VIEW)



DRILLING DIAGRAM(2/1)
(BOTTOM VIEW)

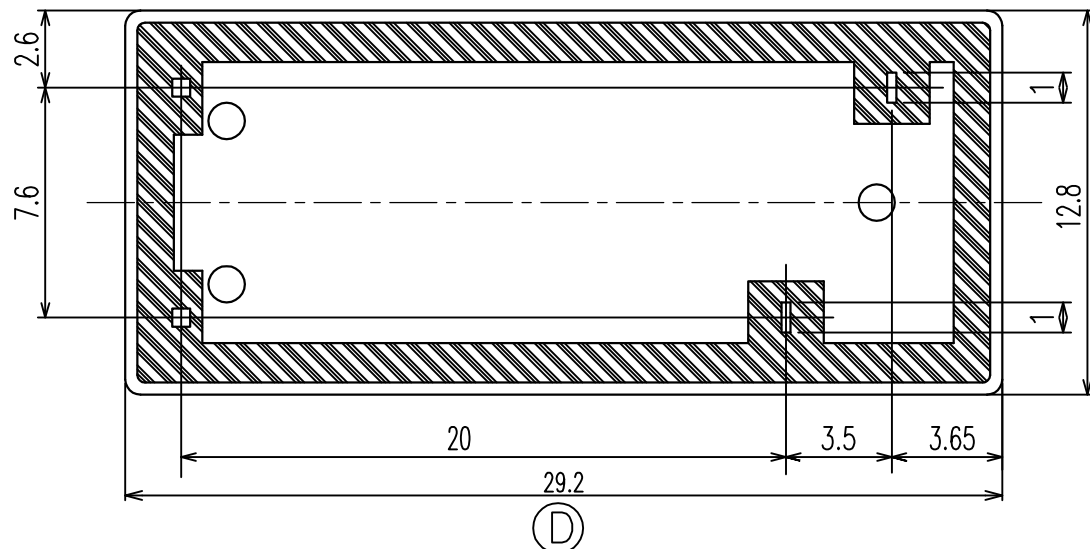
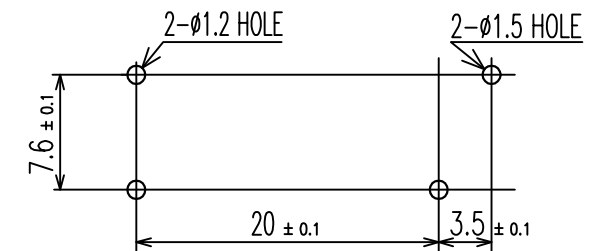

THIS DRAWING IS A CONTROLLED DOCUMENT.

DWN	Y.Xiao	-
CHK	N.Funayama	-
APVD	CH.HSU	-
PRODUCT SPEC	-	-
APPLICATION SPEC	-	-
WEIGHT	-	-
CUSTOMER DRAWING		

TE TE Connectivity

OMIT 1M CUSTOMER DRAWING

DIMENSIONS:	TOLERANCES UNLESS OTHERWISE SPECIFIED:
mm	
	0 PLC ±
	1 PLC ±
	2 PLC ±
	3 PLC ±
	4 PLC ±
	ANGLES ±
	FINISH ±
MATERIAL	-

NAME	SIZE	CAGE CODE	DRAWING NO	RESTRICTED TO
	A3	00779	©=1440001-6	-
SCALE	SHEET	REV		
4:1	1 of 2	F		

THIS DRAWING IS UNPUBLISHED.

RELEASED FOR PUBLICATION

- . - .

© COPYRIGHT By TE Connectivity

ALL RIGHTS RESERVED.

LOC	DIST	REVISIONS			
P	LTR	DESCRIPTION	DATE	DWN	APVD
HB	-	SEE SHEET 1	-	-	-

NOTES:

1.LOT NO. SYSTEM AS FOLLOWING:

0 8 2 5

WEEK

YEAR

2.GENERAL TOLERANCE AS FOLLOWING:

TOLERANCE	
0~0.99mm	±0.1
1mm~2.99mm	±0.2
3mm MIN.	±0.3

③ 3.TERMINAL DIMENSION IS NOT INCLUDING SOLDER TIP.

④ 4.FOR THE TIN-PLATING OF THE PINS:
+0.1mm FOR WIDTH,THICKNESS AND DIAMETER.
+0.5mm FOR LENGTH.

9-144000-7	OMIT-SH-124LM	24V	OMIT-SH-124LM	N
9-144000-5	OMIT-SH-109LM	9V	OMIT-SH-109LM	M
1440001-7	OMIT-SS-148DM	48V	OMIT-SS-148DM	L
1440001-8	OMIT-SS-148LM	48V	OMIT-SS-148LM	k
1440001-5	OMIT-SS-124DM	24V	OMIT-SS-124DM	j
1440001-6	OMIT-SS-124LM	24V	OMIT-SS-124LM	i
1-1461208-2	OMIT-SS-112DM	12V	OMIT-SS-112DM	h
1440001-4	OMIT-SS-112LM	12V	OMIT-SS-112LM	g
1461208-9	OMIT-SS-109DM	9V	OMIT-SS-109DM	f
1440001-1	OMIT-SS-109LM	9V	OMIT-SS-109LM	e
1461208-5	OMIT-SS-106DM	6V	OMIT-SS-106DM	d
1461208-7	OMIT-SS-106LM	6V	OMIT-SS-106LM	c
1461208-3	OMIT-SS-105DM	5V	OMIT-SS-105DM	b
1440001-0	OMIT-SS-105LM	5V	OMIT-SS-105LM	a
PART NO	PART A	PART B	DESCRIPTION	No.

RELAY TYPE

		UV RESIN	UV SEAL	16
		EPOXY RESIN	SEAL	15
UL94 V-0		PBT	CASE	14
CLASS E		UEW	MAGNETIC WIRE	13
UL94 V-0		PET	BASE	12
UL94 V-0		PBT	BOBBIN	11
	SOLDER DIP	CP WIRE	COIL TERMINAL	10
UL94 V-0		PPS	CARD	9
		Ag ALLOY	MOVABLE CONTACT	8
		Ag ALLOY	STATIONARY CONTACT	7
		Cu ALLOY	HINGE SPRING	6
	SOLDER DIP	Cu ALLOY	STATIONARY TERMINAL	5
	SOLDER DIP	Cu ALLOY	MOVABLE SPRING	4
		STEEL	CORE	3
		STEEL	ARMATURE	2
		STEEL	YOKE	1
INCOMBUSTIBILITY	TREATMENT	MATERIAL	DESCRIPTION	ITEM

THIS DRAWING IS A CONTROLLED DOCUMENT.		DWN	-		
		CHK	Y.Xiao		
		APVD	N.Funayama		
		PRODUCT SPEC	CH.HSU		
		APPLICATION SPEC	-		
		WEIGHT	-		
		CUSTOMER DRAWING	-		
DIMENSIONS: mm		TOLERANCES UNLESS OTHERWISE SPECIFIED:			
0 PLC ±		1 PLC ±			
1 PLC ±		2 PLC ±			
2 PLC ±		3 PLC ±			
3 PLC ±		4 PLC ±			
4 PLC ±		ANGLES ±			
MATERIAL		FINISH			
-		-			
		NAME		OMIT 1M CUSTOMER DRAWING	
		SIZE	CAGE CODE	DRAWING NO	RESTRICTED TO
		A3	00779	③=1440001-6	-
		SCALE	SHEET	REV	
		4:1	2 of 2	F	