

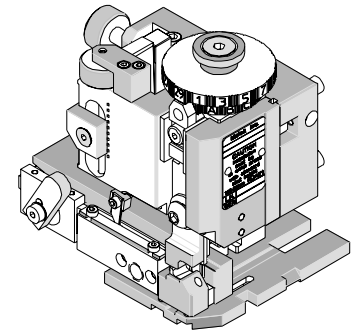

Mini-Mac Applicator Specification Sheet Order No. 63894-2000



FEATURES

- Directly adapts to most automatic wire processing machines
- Applicator designed to industry standard mounting and shut height 135.80mm (5.346")
- Quick set-up time; plus the crimp height, track and feed adjustments can be set without removing the applicator from the press
- Fine adjustment allows users to achieve target with little effort by adjusting in increments of .015mm (.0006") for conductor crimp height and .063mm (.0025") for insulation height
- Independent adjustment rings allow users to quickly adjust the conductor or insulation crimp height without affecting each other.

SCOPE

Products: Male Crimp Pin Terminal, 12 AWG.

Terminal Series No.	Terminal Order No.	Wire Size		Insulation Diameter Maximum		Strip Length	
		AWG	mm ²	mm	In.	mm	In.
1220	02-12-6401	12	3.30	3.68	.145	4.57	.180
	02-12-6402						
	02-12-6403						

DEFINITION OF TERMS

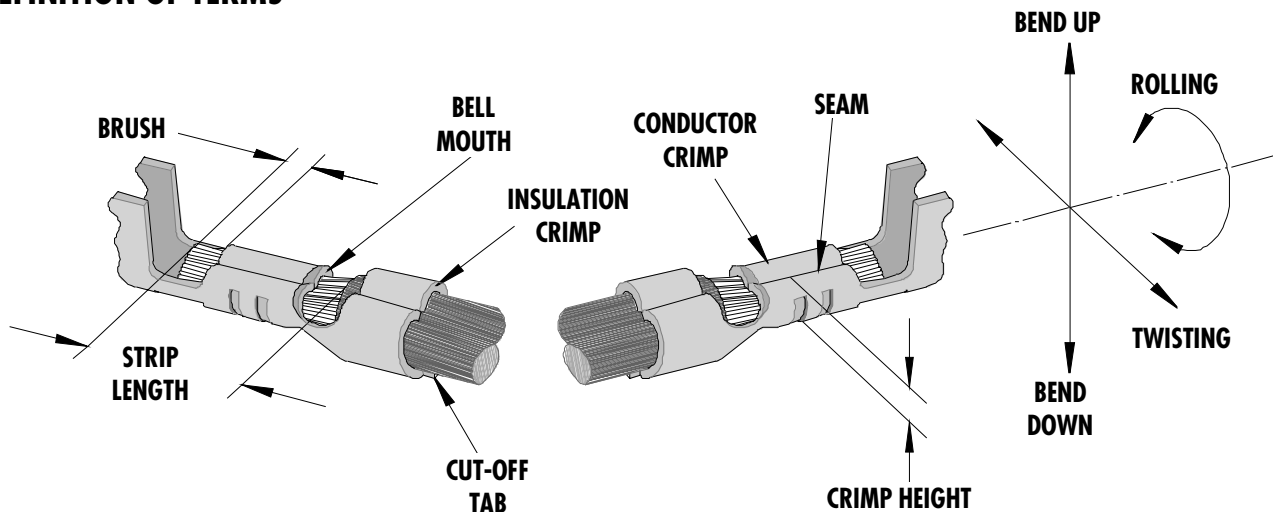

The above terminal drawing is a generic terminal representation. It is not an image of a terminal listed in the scope.

CRIMP SPECIFICATIONS

Terminal Series No.	Bell mouth		Cut-off Tab Maximum		Conductor Brush	
	mm	In.	mm	In.	mm	In.
1220			0.18	.007		

Terminal Series No.	Bend up	Bend down	Twist	Roll	Punch Width (Ref)				Seam Seam shall not be open and no wire allowed out of the crimping area
	Degree		Degree		Conductor		Insulation		
	mm	In.	mm	In.	mm	In.	mm	In.	
1220					3.80	.150	4.89	.192	

After crimping, the conductor profile should measure the following.

Terminal Series No.	Wire Size		Conductor				Pull Force Minimum	
			Crimp Height		Crimp Width			
	AWG	mm ²	mm	In.	mm	In.	N	Lb.
1220	12	3.30	2.26-2.41	.093-.095			311.38	70.0

NOTE: Some of the specifications in these charts above are intentionally left blank due to the fact that the information does not currently exist.

Pull Force should be measured with no influence from the insulation crimp.

The above specifications are guidelines to an optimum crimp.

PARTS LIST

Mini-Mac Applicator 63894-2000				
Item	Order No	Engineering No.	Description	Quantity
Perishable Tooling				
	63894-2070	63894-2070	Tool Kit (All "Y" Items)	REF
1	11-18-4378	60723A101	Conductor Punch	1 Y
2	11-18-4379	60723A102	Conductor Anvil	1 Y
3	11-18-4380	60723A103	Insulation Punch	1 Y
4	11-18-4381	60723A104	Insulation Anvil	1 Y
5	11-18-4383	60723A106	Cut-Off Blade	1 Y
6	11-18-4509	60723A113	Cut-Off Plunger	1 Y
7	11-18-4033	60705A107	Cut-Off Plunger Retainer	1 Y
8	11-18-4242	60710-19	Rear Cut-Off Plunger	1 Y
9	11-18-4241	60710-18	Cut-off Plunger Retainer	1 Y
Other Components (REF 942050)				
10	11-18-4034	60705A108	Front Plunger Striker	1
11	11-18-4382	60723A105	Anvil and Cut-Off Block	1
12	11-18-4388	60723A111	Rear Cut-Off Punch	1
13	11-18-4510	60723A114	Terminal Hold Down	1
14	11-18-4654	60758A109	Tooling Washer	1
15	11-18-4944	60710-21	Compression Spring	2
16	11-40-4670	8365-2	Terminal Hold Down Spring	1
17	63443-0090	63443-0090	Wire Stop	1
18	63443-6140	63443-6140	Cover Rear	1
19	63803-5102	63803-5102	Conductor Bushing	1
Frame				
20	63801-3201	63801-3201	Top	1
21	63801-3282	63801-3282	Base	1
22	63801-6550	63801-6550	Track	1
Hardware				
23	N/A	N/A	M4 by 6 Long SHCS	1**
24	N/A	N/A	M4 by 12 Long BHCS	2**
25	N/A	N/A	M4 by 20 Long SHCS	2**
26	N/A	N/A	M5 by 12 Long SHCS	1**
27	N/A	N/A	M8 by 20 Long BHCS	1**
28	N/A	N/A	#6-32 by 3/8" Long BHCS	4**
29	N/A	N/A	#8-32 by 3/8" Long BHCS	1**
30	N/A	N/A	1/8 Diameter by 1.0" Long Dowel Pin	2**
** Available from an industrial supply company such as MSC (1-800-645-7270).				

Assembly Drawing

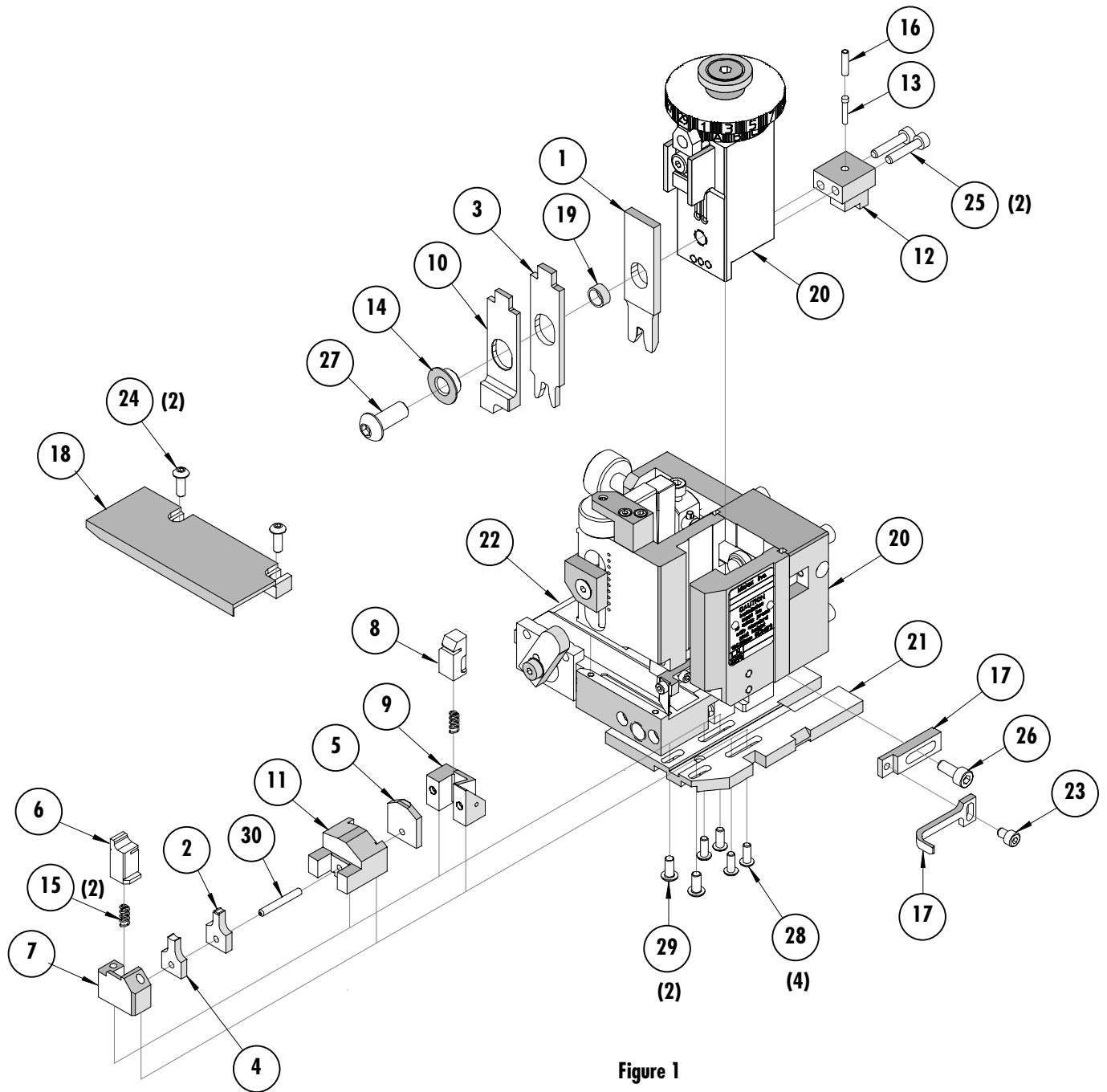

Figure 1

NOTES

1. Molex recommends an extra perishable tooling kit be maintained at your facility.
2. Verify tooling alignment by manually cycling the press and applicator before crimping under power. Check that all screws are tight.
3. Slugs, terminals, dirt, and oil should be kept clear of work area.
4. Wear safety glasses at all times.
5. For recommended maintenance refer to the Mini-Mac Manual.

CAUTION: This applicator should only be used in a press with a shut height of 135.80 mm (5.346"). Tooling damage could result at a lower setting

CAUTION: To prevent injury, never operate this applicator without the guards supplied with the press or wire-processing machine in place. Reference the press or wire processing manufacturer's instruction manual.

CAUTION: Molex crimp specifications are valid only when used with Molex terminals, applicators and tooling.

Contact Information

For more information on Molex application tooling please contact Molex at 1-800-786-6539.

Americas Headquarters

Lisle, Illinois 60532 U.S.A.
1-800-78MOLEX
amerinfo@molex.com

Far East North Headquarters

Yamato, Kanagawa, Japan
81-462-65-2324
feninfo@molex.com

Far East South Headquarters

Jurong, Singapore
65-6-268-6868
fesinfo@molex.com

European Headquarters

Munich, Germany
49-89-413092-0
eurinfo@molex.com

Corporate Headquarters

2222 Wellington Ct.
Lisle, IL 60532 U.S.A.
630-969-4550
Fax: 630-969-1352

Visit our Web site at <http://www.molex.com>