

REVISIONS				
P	LTN	DESCRIPTION	DATE	APVD
A		INITIAL	03JUN2016	RL CW
A1		ECR-16-012141	30AUG2016	RL CW
A2		ECR-16-015006	26OCT2016	RL CW

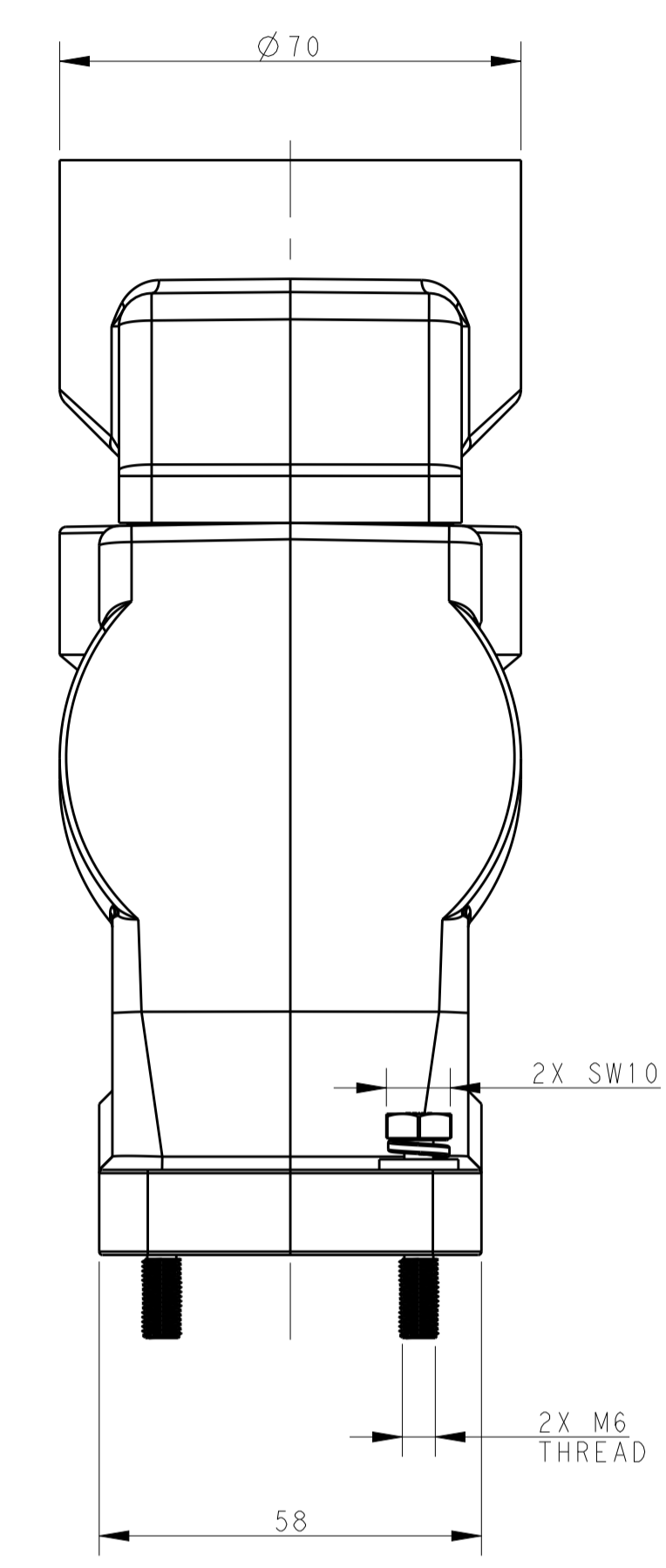

NOTES:
 1. TECHNICAL CHARACTERISTICS:
 HOOD MATERIAL: DIE CAST ALUMINIUM ALLOY
 SURFACE TREATMENT: POWDER COATED, BLACK
 DEGREE OF PROTECTION: IP68 (MATED)

注释:
 1. 技术参数:
 壳体材料: 铝合金
 表面处理: 黑色粉末喷涂
 防护等级: IP68 (配合)

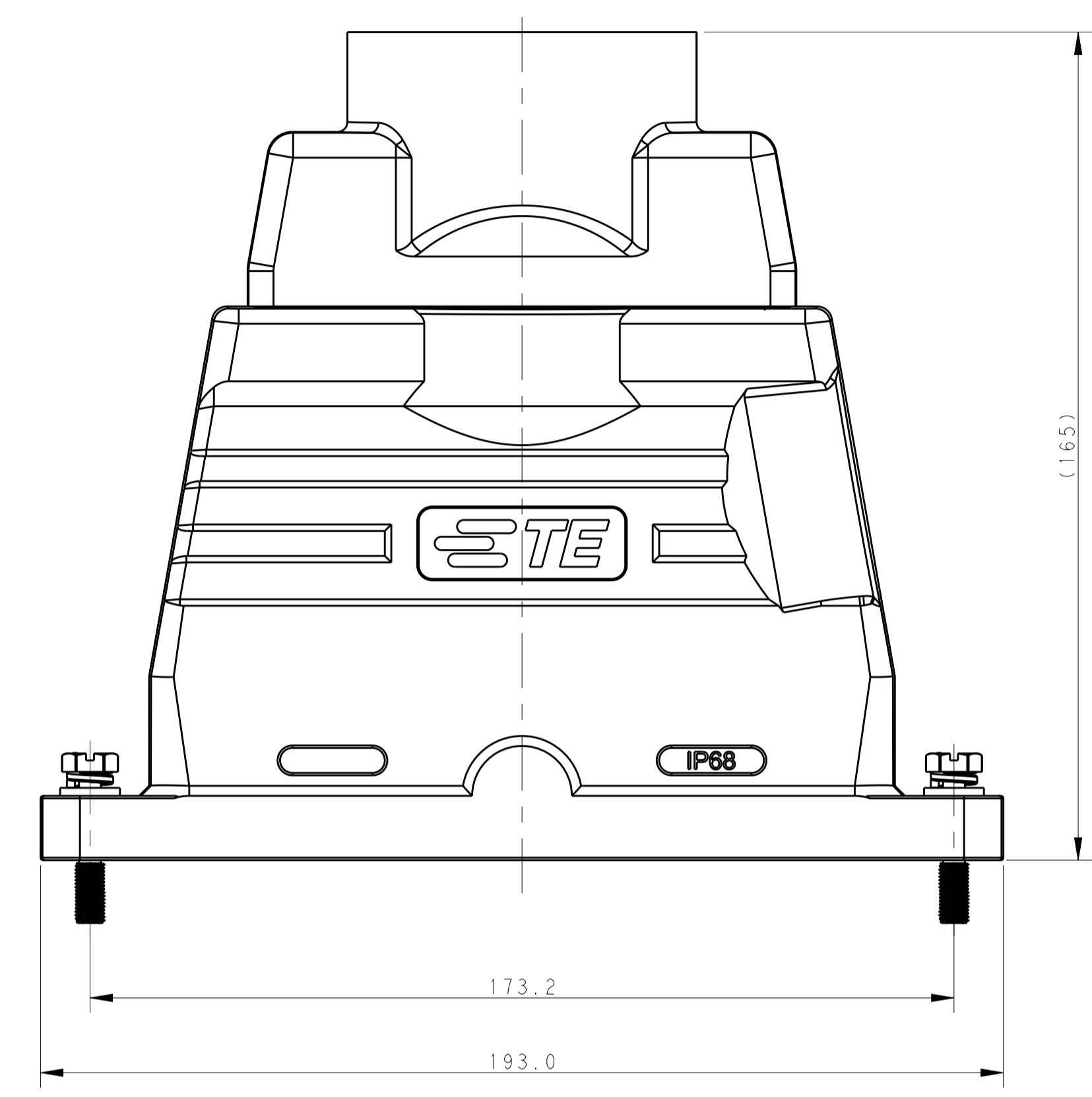
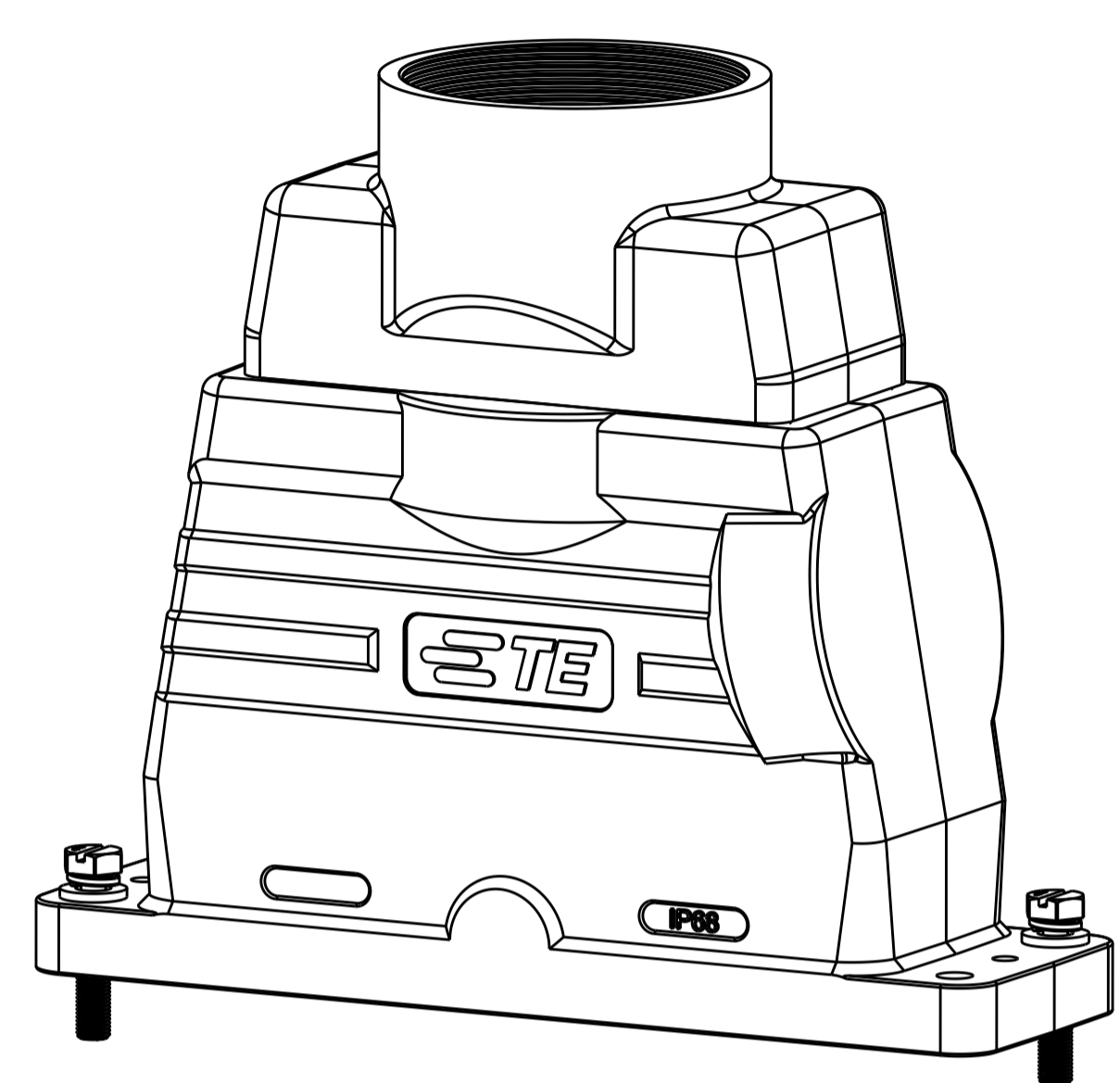
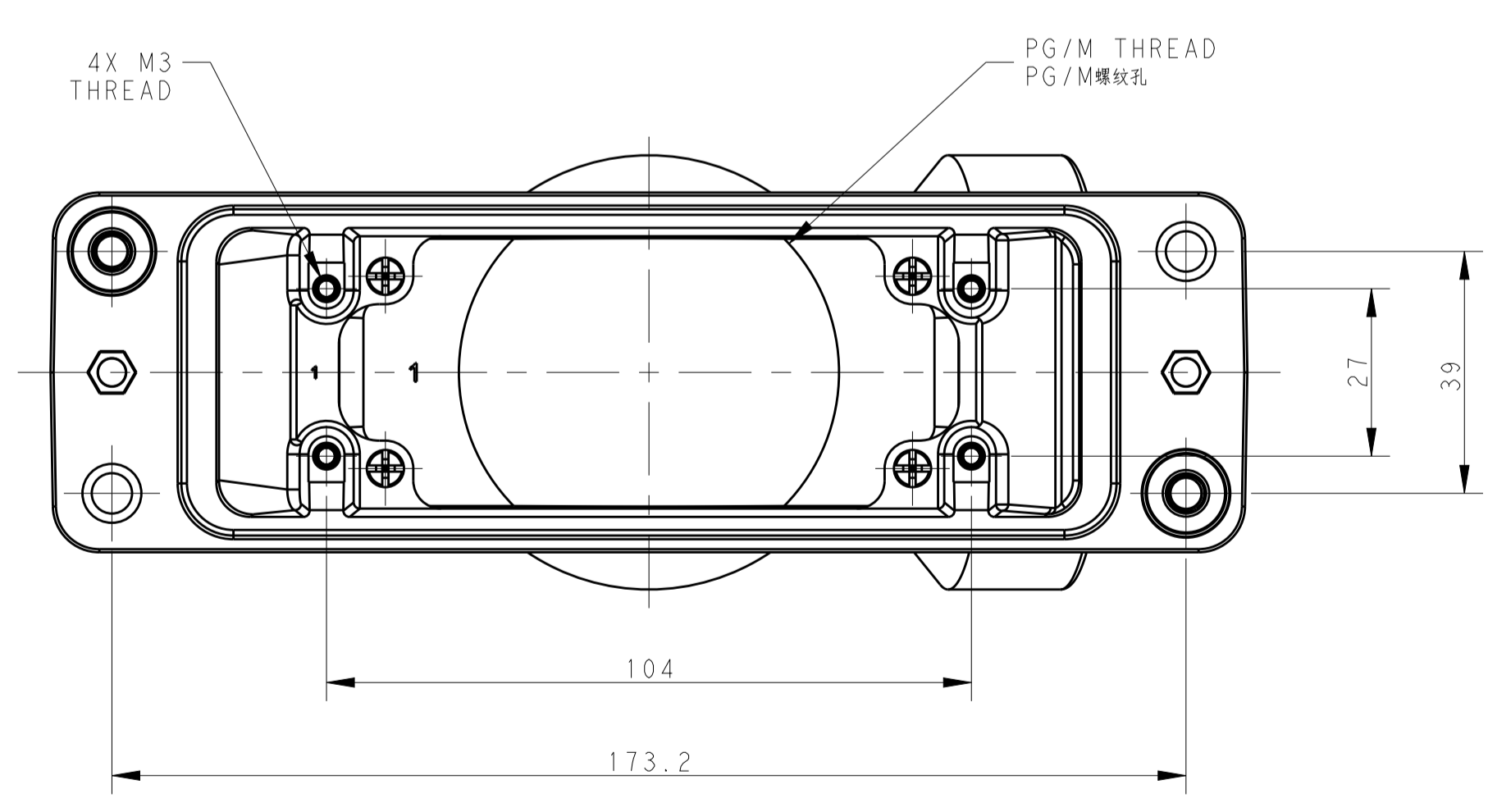

T1926240150-000	H24BPR-TGXH-4S-M50	H24BPR HEIGHTEN HOOD, QUADRANGLED LOCKING, TOP ENTRY M50, POWDER COATED, BLACK H24BPR加高上壳, 四角锁定, 顶出M50, 黑色粉末喷涂	M50
T1926240163-000	H24BPR-TGXH-4S-M63	H24BPR HEIGHTEN HOOD, QUADRANGLED LOCKING, TOP ENTRY M63, POWDER COATED, BLACK H24BPR加高上壳, 四角锁定, 顶出M63, 黑色粉末喷涂	M63
PART NUMBER 料号	PART DESCRIPTION 描述		PG/M THREAD PG/M螺纹孔

THIS DRAWING IS A CONTROLLED DOCUMENT.		DWN: ROY LIU 03JUN2016	TE Connectivity
DIMENSIONS: mm		CHK: KYLE ZENG 03JUN2016	
TOLERANCES UNLESS OTHERWISE SPECIFIED:		APVD: CHRIS WANG 03JUN2016	NAME: H24BPR-TGXH-4S-MXX
0 PLC ±	1 PLC ±	2 PLC ±	3 PLC ±
4 PLC ±	ANGLES ±	FINISH ±	RESTRICTED TO
MATERIAL	WEIGHT	SIZE: A1	CAGE CODE: -
CUSTOMER DRAWING		SCALE: 1:1	SHEET 1 OF 1 REV: A2