

PART NAME: KNOB SCALE: 1:1 DATE: 3/15/05 DR. BY JAM

DAVIES MOLDING COMPANY
CAROL STREAM, ILLINOIS 60188

P/N 1507

THIS DRAWING IS THE PROPERTY OF DAVIES MOLDING COMPANY, IS SUBMITTED SOLELY AS A DESIGN OR ENGINEERING PROJECT.
WE ACCEPT NO RESPONSIBILITY WHATSOEVER FOR THE PRACTICAL APPLICATION OF THE PIECES MADE TO THIS DESIGN.

MOLD #	1507
CAVITY	1507
CORE	1507
PIN	1507

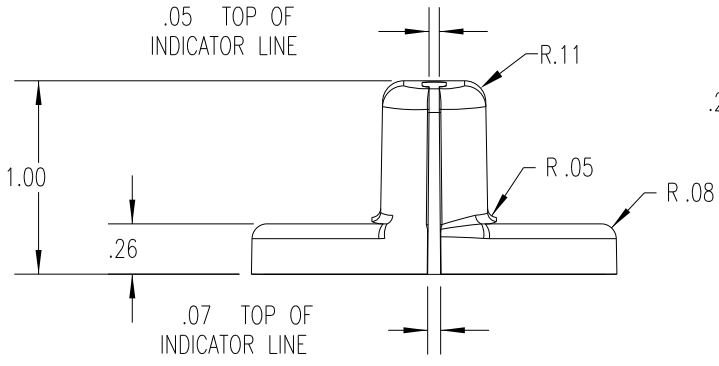
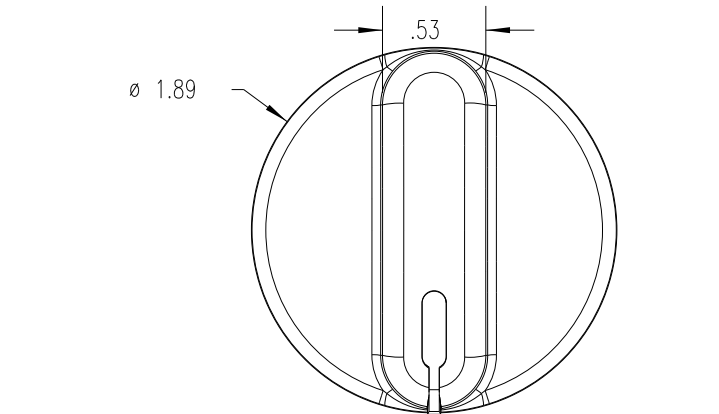

.07 TOP OF INDICATOR LINE

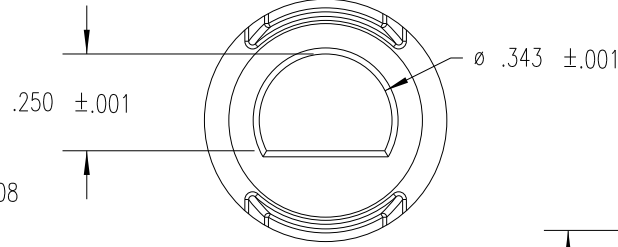
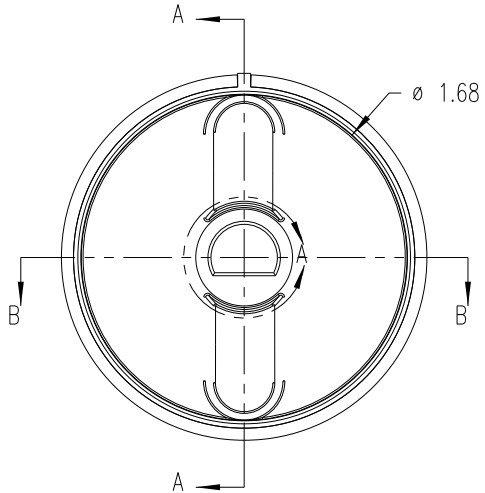

DETAIL A
SCALE 2 : 1

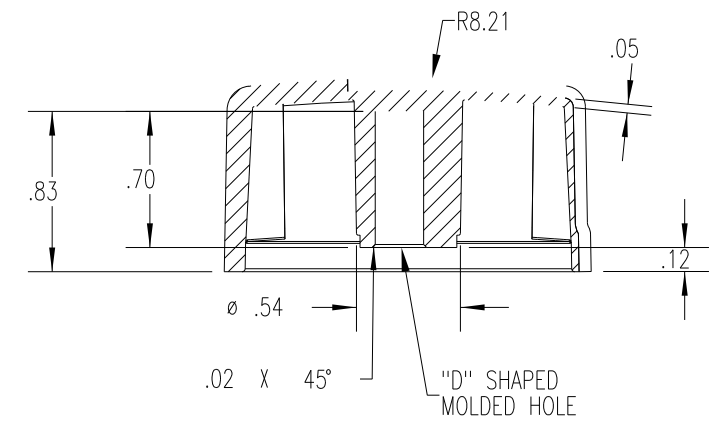

SECTION A-A

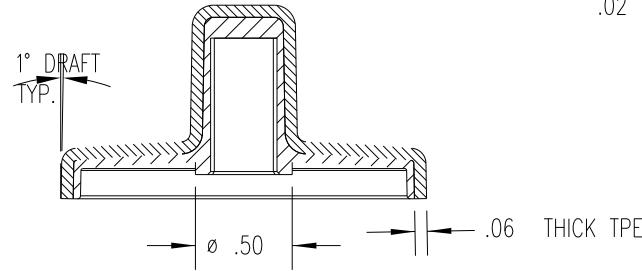

SECTION B-B

SUBSTRATE MATERIAL: NYLON 6/6 (CLC)
COLOR: WHITE (PC23083) (A)(B)(C)
OVERMOLD MATERIAL: NYLON 6/6 (CLC)
COLOR: RED (NC301100)

TOLERANCES: UNLESS OTHERWISE SPECIFIED	DO NOT SCALE DRAWING	C	ADDED COLOR # PC23083	DS	10/16/06
		B	COLOR # WAS PC-7387	JAM	2/8/06
DECIMALS: X.XXX ± .005 X.XX ± .015	MM: X.XX ± 0.15MM X.X ± 0.4MM	A	ADDED COLOR #	JAM	10/28 /05
		-	WAS SK1507-04	JAM	10/19/05
FRACTIONS ± 1/64	ANG. ± 1°	CHANGES			