



IQS622 Datasheet

Combination sensor with ambient light sensing (ALS), active IR, Hall-effect and two-channel capacitive proximity/touch sensor

The IQS622 ProxFusion® IC is a multifunctional ambient light sensing (ALS), active IR, capacitive & Hall-effect sensor designed for applications where any or all of the technologies may be required. The IQS622 is an ultra-low power solution designed for short or long term activations through any of the sensing channels. The IQS622 is fully I²C compatible and can be configured to operate on an event mode basis to wake-up on dedicated sensors.

Features

- **Unique combination of sensing technologies:**
 - Capacitive sensing
 - Ambient light sensing (ALS)
 - Active IR proximity sensor
 - Hall-effect sensing
- **Capacitive sensing**
 - Full auto-tuning with adjustable sensitivity
 - 2pF to 200pF external capacitive load capability
 - Enhanced temperature stability
- **Ambient light sensing (ALS)**
 - 4-bit ALS range output (0 - 10)
- **Active IR proximity sensor**
 - 60mm range
 - Pulsed LED current for lower power
 - 2 Level detection with hysteresis
- **Hall-effect sensing**
 - On-chip Hall-effect measurement plates
 - Dual direction Hall switch sensor UI
 - 2 level detection (widely variable)
 - Detection range 10mT – 200mT
- **Multiple integrated UI options** based on years of experience in sensing on fixed and mobile platforms:
 - Proximity wake-up / Touch; SAR; Hysteresis
- **Automatic Tuning Implementation (ATI)** – performance enhancement (10bit)
- **Minimal external components**
- **Optional RDY indication** for event mode operation
- **Low power consumption:**
 - 60µA (100Hz response, 2ch capacitive)
 - 42µA (100Hz response, capacitive SAR)
 - 26µA (100Hz response, ALS)
 - 32µA (100Hz response, active IR)
 - 80µA (100Hz response, 2ch Hall-effect)
 - 17µA (20Hz response, 2ch capacitive)
 - 42µA (20Hz response, capacitive SAR)
 - 8µA (20Hz response, ALS)
 - 10µA (20Hz response, active IR)
 - 22µA (20Hz response, 2ch Hall-effect)
 - 2.5µA (4Hz response, 1ch cap. wake-up)
- **Supply voltage: 2.0V to 3.3V**
- **Low profile DMA – 3.94 x 2.36 x 1.37 – 9-pin package**

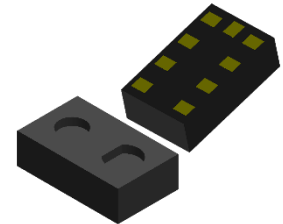

DMA -3.94 x 2.36 x 1.37
9-pin
Representations only

Applications

- **Laptops, Notebooks, Mobile phones, Tablets**
 - On-ear detection
 - Screen brightness adjust
 - Keyboard backlight adjust
 - Smart cover detection and orientation
 - SAR
 - Touch volumes controls

Available Packages	
T _A	DMA – 3.94 x 2.36 x 1.37 – 9N
-20°C to +85°C	IQS622



Table of Contents

LIST OF ABBREVIATIONS	4
1 INTRODUCTION	5
1.1 PROXFUSION®	5
1.2 PACKAGING AND PIN-OUT	6
1.3 REFERENCE SCHEMATIC	7
1.4 SENSOR CHANNEL COMBINATIONS	8
1.5 PROXFUSION® SENSITIVITY	9
2 CAPACITIVE SENSING	10
2.1 INTRODUCTION TO PROXSENSE®	10
2.2 CHANNEL SPECIFICATIONS	10
2.3 HARDWARE CONFIGURATION	11
2.4 SOFTWARE CONFIGURATION	12
2.5 SENSOR DATA OUTPUT AND FLAGS	13
3 AMBIENT LIGHT SENSING (ALS)	14
3.1 INTRODUCTION TO AMBIENT LIGHT SENSING	14
3.2 CHANNEL SPECIFICATIONS	14
3.3 HARDWARE CONFIGURATION	14
3.4 SOFTWARE CONFIGURATION	14
3.5 SENSOR DATA OUTPUT AND FLAGS	15
4 ACTIVE INFRA-RED (IR)	16
4.1 INTRODUCTION TO ACTIVE IR SENSING	16
4.2 CHANNEL SPECIFICATIONS	16
4.3 HARDWARE CONFIGURATION	16
4.4 SOFTWARE CONFIGURATION	16
4.5 SENSOR DATA OUTPUT AND FLAGS	17
5 HALL-EFFECT SENSING	18
5.1 INTRODUCTION TO HALL-EFFECT SENSING	18
5.2 CHANNEL SPECIFICATIONS	18
5.3 HARDWARE CONFIGURATION	19
5.4 SOFTWARE CONFIGURATION	20
5.5 SENSOR DATA OUTPUT AND FLAGS	21
6 DEVICE CLOCK, POWER MANAGEMENT AND MODE OPERATION	22
6.1 DEVICE MAIN OSCILLATOR	22
6.2 DEVICE MODES	22
6.3 SYSTEM RESET	23
7 COMMUNICATION	24
7.1 I ² C MODULE SPECIFICATION	24
7.2 I ² C READ	24
7.3 I ² C WRITE	24
7.4 DEVICE ADDRESS AND SUB-ADDRESSES	25
7.5 ADDITIONAL OTP OPTIONS	25
7.6 RECOMMENDED COMMUNICATION AND RUNTIME FLOW DIAGRAM	26
8 MEMORY MAP	27
8.2 DEVICE INFORMATION DATA	29
8.3 FLAGS AND USER INTERFACE DATA	30
8.4 CHANNEL COUNTS (RAW DATA)	34
8.5 LTA VALUES (FILTERED DATA)	34
8.6 PROXFUSION SENSOR SETTINGS	35
8.7 PROXFUSION UI SETTINGS	39



8.8	SAR UI SETTINGS.....	40
8.9	LIGHT SENSOR SETTINGS	42
8.10	ACTIVE IR UI SETTINGS.....	45
8.11	HALL-EFFECT SENSOR SETTINGS.....	47
8.12	HALL-EFFECT SWITCH UI SETTINGS.....	49
8.13	DEVICE AND POWER MODE SETTINGS	50
9	ELECTRICAL CHARACTERISTICS	54
9.1	ABSOLUTE MAXIMUM SPECIFICATIONS.....	54
9.2	VOLTAGE REGULATION SPECIFICATIONS.....	54
9.3	RESET CONDITIONS	54
9.4	I ² C MODULE OUTPUT LOGIC FALL TIME LIMITS	55
9.5	I ² C MODULE SLEW RATES	56
9.6	I ² C PINS (SCL & SDA) INPUT/OUTPUT LOGIC LEVELS	57
9.7	GENERAL PURPOSE DIGITAL OUTPUT PINS (GPIO0 & GPIO3) LOGIC LEVELS.....	57
9.8	INFRARED LED CHARACTERISTICS	58
9.9	CURRENT CONSUMPTIONS	59
9.10	START-UP TIMING SPECIFICATIONS.....	62
10	PACKAGE INFORMATION	63
10.1	DMA-3.94 x 2.36 x 1.37 – 9-PIN PACKAGE AND FOOTPRINT SPECIFICATIONS	63
10.2	DEVICE MARK AND ORDERING INFORMATION	64
10.3	BULK PACKAGING SPECIFICATION	65
10.4	MSL LEVEL	67
11	DATASHEET REVISIONS	68
11.1	REVISION HISTORY	68
11.2	ERRATA	68
APPENDIX A. CONTACT INFORMATION		69
APPENDIX B. HALL ATI		70



List of abbreviations

AC	– Alternating Current
ACK	– I ² C Acknowledge condition
ALS	– Ambient Light Sensing
ATI	– Automatic Tuning Implementation
BOD	– Brown Out Detection
CS	– Sampling Capacitor
DSP	– Digital Signal Processing
ESD	– Electrostatic Discharge
FOSC	– Main Clock Frequency Oscillator
GND	– Ground
GPIO	– General Purpose Input Output
I ² C	– Inter-Integrated Circuit
IC	– Integrated Circuit
IR	– Infra-Red
LP	– Low Power
LPOSC	– Low Power Oscillator
LTA	– Long Term Average
LTX	– Inductive Transmitting electrode
MCU	– Microcontroller unit
MSL	– Moisture Sensitive Level
MOQ	– Minimum Order Quantity
NACK	– I ² C Not Acknowledge condition
NC	– Not Connect
NP	– Normal Power
OTP	– One Time Programmable
PMU	– Power Management Unit
POR	– Power On Reset
PWM	– Pulse Width Modulation
QRD	– Quick Release Detection
RDY	– Ready Interrupt Signal
RX	– Receiving electrode
SAR	– Specific Absorption Rate
SCL	– I ² C Clock
SDA	– I ² C Data
THR	– Threshold
UI	– User Interface
ULP	– Ultra Low Power



1 Introduction

1.1 ProxFusion®

The ProxFusion® sensor series provide all of the proven ProxSense® engine capabilities with additional sensors types. A combined sensor solution is available within a single platform.

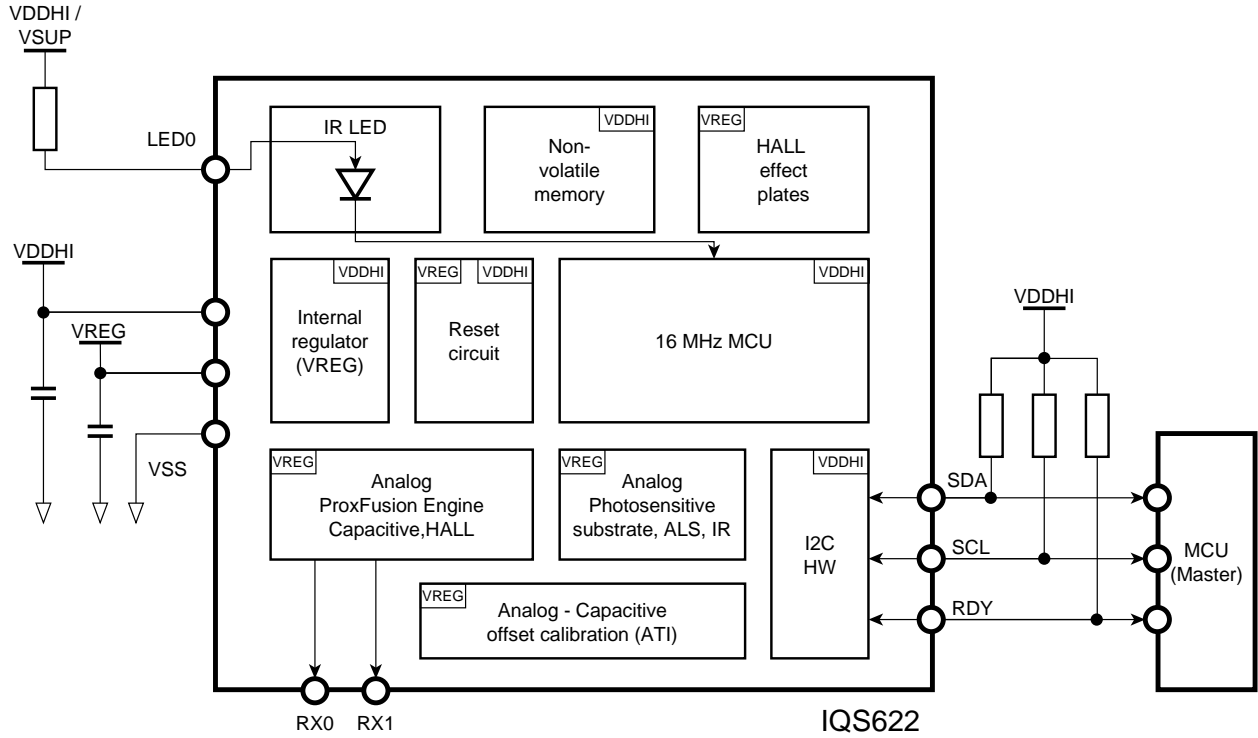

Figure 1.1 IQS622 functional block diagram

1.2 Packaging and Pin-Out

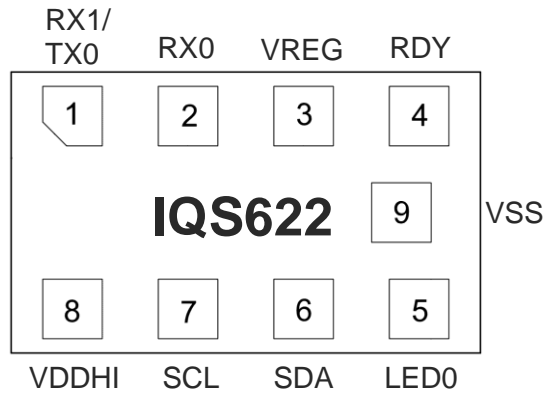

Figure 1.2 IQS622 pin-out (DMA 3.94x2.36x1.37–9N package top view; markings not realistic)

Table 1.1 Pin-out description

IQS622 in DMA 3.94 x 2.36 x 1.37 – 9-pin			
Pin	Name	Type	Function
1	RX1/TX0	Receiving electrode / Transmitter electrode	Connect to conductive area intended for sensor receiving / transmitting
2	RX0	Receiving electrode	Connect to conductive area intended for sensor receiving
3	VREG	Regulator output	Requires external capacitor
4	RDY	Digital Input / Output	RDY (I ² C Ready interrupt signal)
5	LED0	Internal LED anode	Connect to voltage supply with serial current limiting resistor.
6	SDA	Digital Input / Output	SDA (I ² C Data signal)
7	SCL	Digital Input / Output	SCL (I ² C Clock signal)
8	VDDHI	Supply Input	Supply: 2.0V – 3.3V
9	VSS	Signal GND	Common ground reference

1.3 Reference schematic

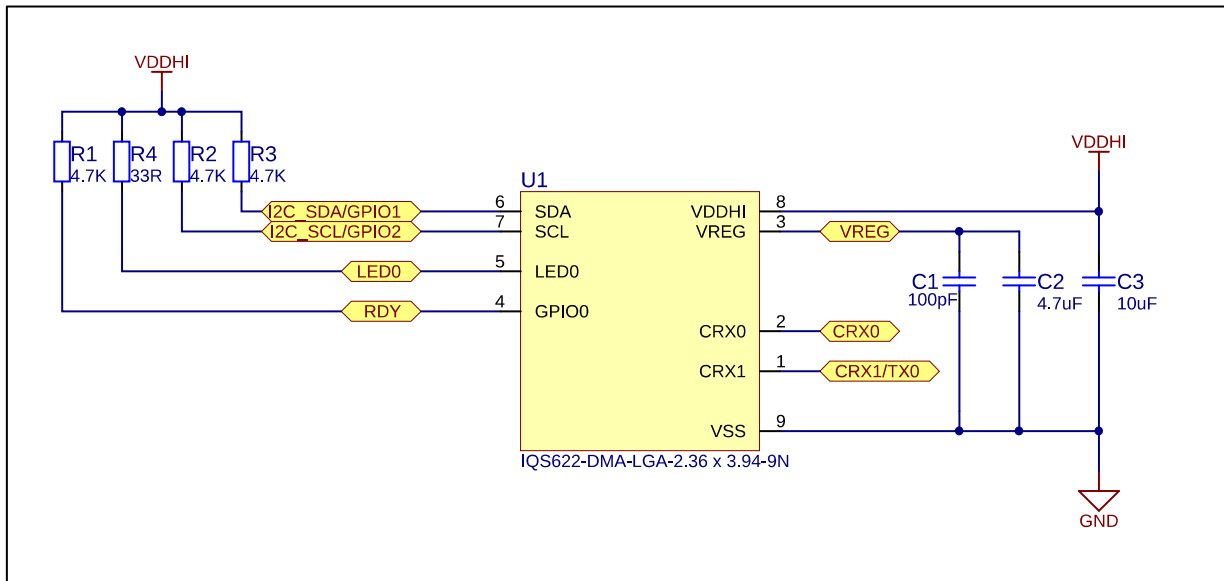

Figure 1.3 IQS622 reference schematic



1.4 Sensor channel combinations

The table below summarizes the IQS622's sensor and channel associations.

Table 1.2 Sensor channel allocation

	Sensor/UI type	CH0	CH1	CH2	CH3	CH4	CH5	CH6
Capacitive	Self / Projected	○	○					
	SAR UI	● Main	● Movement					
ALS	Ambient light sensing			●				
IR	Active Infra-Red				●	●		
Hall-effect	Hall-effect switch UI						● Positive	● Negative

Key:

- - Optional implementation
- - Fixed use for UI



1.5 ProxFusion® sensitivity

The measurement circuitry uses a temperature stable internal sample capacitor (C_S) and internal regulated voltage (V_{REG}). Internal regulation provides for more accurate measurements over temperature variation. The size C_S can be decreased to increase sensitivity on the capacitive channels of the IQS622.

$$Sensitivity \propto \frac{1}{C_S}$$

The Automatic Tuning Implementation (ATI) is a sophisticated technology implemented on the ProxFusion® series devices. It allows for optimal performance of the devices for a wide range of sense electrode capacitances, without modification or addition of external components. The ATI functionality ensures that sensor sensitivity is not affected by external influences such as temperature, parasitic capacitance and ground reference changes.

The ATI process adjusts three values (Coarse multiplier, Fine multiplier, Compensation) using two parameters (ATI base and ATI target) as inputs. A 10-bit compensation value ensures that an accurate target is reached. The base value influences the overall sensitivity of the channel and establishes a base count from where the ATI algorithm starts executing. A rough estimation of sensitivity can be calculated as:

$$Sensitivity \propto \frac{Target}{Base}$$

As seen from this equation, the sensitivity can be increased by either increasing the Target value or decreasing the Base value. A lower base value will typically result in lower multipliers and more compensation would be required. It should, however, be noted that a higher sensitivity will yield a higher noise susceptibility. Refer to Appendix B. Hall ATI for more information on Hall ATI.



2 Capacitive sensing

2.1 Introduction to ProxSense®

Building on the previous successes from the ProxSense® range of capacitive sensors, the same fundamental sensor engine has been implemented in the ProxFusion® series.

The capacitive sensing capabilities of the IQS622 include:

- Self and projected capacitive sensing.
- Maximum of 2 capacitive channels to be individually configured.
 - Prox and touch adjustable thresholds
 - Individual sensitivity setups
 - Alternative ATI modes
- Enhanced SAR user interface:
 - For passing the SAR qualification
 - Movement sensing to distinguish between stationary in-contact objects and human interference
 - Quick release feature (fully customizable)
- Discreet button UI:
 - Fully configurable 2 level threshold setups – Traditional Prox & Touch activation levels.
 - Customizable filter halt time

2.2 Channel specifications

The IQS622 provides a maximum of 2 channels available to be configured for capacitive sensing. Each channel can be setup separately according to the channel's associated settings registers.

There are two distinct capacitive user interfaces available to be used.

- a) Self/projected capacitive proximity/touch UI (always enabled)
- b) SAR UI

When the SAR UI is activated (ProxFusion settings4: bit7):

- Channel 0 is used for as the main capacitive sensing channel for SAR detection.
- Channel 1 is used for capacitive movement detection. This is used to improve the SAR detection such as quick release detection.

Table 2.1 Capacitive sensing - channel allocation

Mode	CH0	CH1	CH2	CH3	CH4	CH5	CH6
Self / Projected	○	○					
SAR UI	• Main	• Movement					

Key:

- - Optional implementation
- - Fixed use for UI

2.3 Hardware configuration

In the table below are multiple options of configuring sensing (RX) and transmitting (TX) electrodes to realize different implementations (combinations not shown).

Table 2.2 Capacitive sensing - hardware description

	Self capacitive	Projected capacitive
1 button		
2 buttons		
SAR antenna		



2.4 Software configuration

2.4.1 Registers to configure for capacitive sensing:

Table 2.3 Capacitive sensing settings registers

Address	Name	Description	Recommended setting
0x40 0x41	ProxFusion Settings 0	Sensor mode and configuration of each channel.	Sensor mode should be set to capacitive mode An appropriate RX and TX should be chosen
0x42 0x43	ProxFusion Settings 1	Channel settings for the ProxSense sensors	Full ATI is recommended for fully automated sensor tuning.
0x44 0x45	ProxFusion Settings 2	ATI settings for ProxSense sensors	ATI target should be more than ATI base to achieve an ATI
0x46 0x47	ProxFusion Settings 3	Additional Global settings for ProxSense sensors	None
0x48	ProxFusion Settings 4	UI enable command and filter settings	Enable the SAR UI
0x49	ProxFusion Settings 5	Advance sensor settings	None
0x50 0x52	Prox threshold	Prox Thresholds for all capacitive channels (except for SAR active on channel 0)	Preferably more than touch threshold
0x51 0x53	Touch threshold	Touch Thresholds for all capacitive channels	None
0x54	ProxFusion discrete UI halt time	Halt timeout setting for all capacitive channels	None

2.4.2 Registers to configure for the SAR UI:

Table 2.4 SAR UI settings registers

Address	Name	Description
0x48	ProxFusion settings 4	SAR UI enable command
0x60	SAR UI Settings 0	Filter settings for movement and QRD, SAR activation output to GPIO0 (RDY signal disabled)
0x61	SAR UI Settings 0	LTA halt timeout and movement threshold settings
0x62	Quick release threshold Ch0	Threshold setting to trigger a quick release based on the Quick release count values in register 0xF2 & 0xF3.
0x63	Filter halt threshold Ch0	Threshold value for channel 0 LTA filter halt
0x64	SAR Prox threshold Ch0	Prox threshold used for SAR activations on channel 0
0x65	Quick release halt time	Halt timeout setting for channel 0 LTA after a quick release trigger with zero movement



2.4.3 Example code:

Example code for an Arduino Uno can be downloaded at:

www.azoteq.com/images/stories/software/IQS62x_Demo.zip

2.5 Sensor data output and flags

The following registers should be monitored by the master to detect capacitive sensor output and SAR activations.

- a) The **Global events register (0x11)** will show the IQS622's main events. Bit0 is dedicated to the ProxSense activations and bit1 is allocated to show SAR events. SAR_EVENT (bit1) will toggle upon each SAR qualified event.

Global events (0x11)								
Bit Number	7	6	5	4	3	2	1	0
Data Access	-	R	R	R	R	R	R	R
Name	-	POWER MODE EVENT	SYS EVENT	ACTIVE IR EVENT	ALS EVENT	HALL EVENT	SAR EVENT	PROX SENSE EVENT

- b) The **ProxSense UI flags (0x12)** and **SAR UI flags (0x13)** provide more detail regarding the outputs. A prox and touch output bit for each channel 0 to 3 is provided in the ProxSense UI Flags register.
- c) The **SAR UI flags (0x13)** register will show detail regarding the state of the SAR output (**SAR ACTIVE**) as well as quick release toggles, movement activations and the state of the filter (halted or not).

ProxSense UI flags (0x12)								
Bit Number	7	6	5	4	3	2	1	0
Data Access	-	-	R	R	-	-	R	R
Name	-	-	CH1_T	CH0_T	-	-	CH1_P	CH0_P

SAR UI flags (0x13)								
Bit Number	7	6	5	4	3	2	1	0
Data Access	-	-	-	R	R	R	R	R
Name	-	-	-	SAR ACTIVE	HAND HELD MODE	QUICK RELEASE	MOVEMENT	FHALT



3 Ambient light sensing (ALS)

3.1 Introduction to ambient light sensing

The IQS622 employs one light sensitive semi-conductor areas on chip to realise an ambient light sensor. The sensor capabilities include:

- 4-bit ALS value output (0 – 10).

3.2 Channel specifications

The IQS622 provides 1 dedicated channel to ALS conversions.

Table 3.1 Ambient light sensing - channel allocation

Mode	CH0	CH1	CH2	CH3	CH4	CH5	CH6
ALS			•				

Key:

- - Optional implementation
- - Fixed use for UI

Please note:

- CS size, multipliers and charge frequency are adjustable.
- **Ch2 – ALS channel 1:**
 - Assigned to narrow spectrum ALS

3.3 Hardware configuration

No external hardware required. Package placement and lens clearance required.

3.4 Software configuration

3.4.1 Registers to configure for ALS sensing:

Table 3.2 ALS sensing settings registers

Address	Name	Description	Recommended setting
0x70	ALS Settings 0	ALS conversion settings and filter configuration settings	None
0x71	ALS Settings 1	ALS channel ATI target and multiplier calibration value	None

3.4.2 Example code:

Example code for an Arduino Uno can be downloaded at:

www.azoteq.com/images/stories/software/IQS62x_Demo.zip



3.5 Sensor data output and flags

The following registers can be monitored by the master to detect ALS related events.

- a) The **ALS EVENT (bit 3)** in the **Global events (0x11)** register are dedicated to ALS related events. This bit will toggle when the ALS value change in any direction. The ALS event bit will automatically clear by reading the **Global events (0x11)** register.

Global events (0x11)								
Bit Number	7	6	5	4	3	2	1	0
Data Access	-	R	R	R	R	R	R	R
Name	-	POWER MODE EVENT	SYS EVENT	ACTIVE IR EVENT	ALS EVENT	HALL EVENT	SAR EVENT	PROX SENSE EVENT

- b) The **ALS UI flags (0x14)** register provides a 4 bit ALS value to indicate the magnitude of the current ALS reading (**ALS range value bit 0-3**). The ALS value ranges from 0 to 10.

ALS UI flags (0x14)								
Bit Number	7	6	5	4	3	2	1	0
Data Access	-				R	R	R	R
Name	Reserved				ALS range value			



4 Active Infra-Red (IR)

4.1 Introduction to active IR sensing

The IQS622 employs two light sensitive semi-conductor areas to realise an active IR sensor. The sensor capabilities include:

- 60mm detection range
- Pulsed LED current for lower power
- Two threshold levels are provided
- Prox/Touch indication provided.

4.2 Channel specifications

The IQS622 provides 2 dedicated channels to IR conversions.

Table 4.1 Active IR sensing - channel allocation

Mode	CH0	CH1	CH2	CH3	CH4	CH5	CH6
Active IR				•	•		

Key:

- - Optional implementation
- - Fixed use for UI

Please note:

- CS size, multipliers and charge frequency divider are adjustable.
- **Ch3 – IR channel 1:**
 - Assigned to wide spectrum IR
 - LED driver inactive
- **Ch4 – IR channel 2:**
 - Assigned to wide spectrum IR
 - LED driver active

4.3 Hardware configuration

No external hardware required. Package placement and lens clearance required. Packaged IR LED pull-up resistance used to regulate IR transmitted power.

4.4 Software configuration

4.4.1 Registers to configure for active IR sensing:

Table 4.2 Active IR sensing settings registers

Address	Name	Description	Recommended setting
0x70	IR Settings 0	IR conversion settings and filter configuration settings	None
0x71	IR Settings 1	IR channels ATI target and multiplier calibration value	None

4.4.2 Example code:

Example code for an Arduino Uno can be downloaded at:

www.azoteq.com/images/stories/software/IQS62x_Demo.zip



4.5 Sensor data output and flags

The following registers can be monitored by the master to detect active IR related events.

- c) The **ACTIVE_IR_EVENT (bit 2)** in the **Global events (0x11)** register are dedicated to Active IR related events. This bit will toggle when the IR prox flag is set and is automatically cleared after reading the register.

Global events (0x11)								
Bit Number	7	6	5	4	3	2	1	0
Data Access	-	R	R	R	R	R	R	R
Name	-	POWER MODE EVENT	SYS EVENT	ACTIVE IR EVENT	ALS EVENT	HALL EVENT	SAR EVENT	PROX SENSE EVENT

- d) The **Active IR flags (0x15)** register will provide a value between 0 and 10 to indicate the amount of IR energy entering the IQS622.

Active IR flags (0x15)								
Bit Number	7	6	5	4	3	2	1	0
Data Access	-	-	-	-	R	R	R	R
Name	-	-	-	-	IR range value			

- e) The **Active IR UI flags (0x16)** register provides a classic two level prox/touch activation (**ACTIVE_IR_POUT** & **ACTIVE_IR_TOUT**). The thresholds for both are fully configurable in registers 0x91 and 0x92.

Active IR UI flags (0x16)								
Bit Number	7	6	5	4	3	2	1	0
Data Access	-	-	-	-	-	-	R	R
Name	-	-	-	-	-	-	ACTIVE IR TOUT	ACTIVE IR POUT

- f) The **Active IR UI output (0x17 - 0x18)** registers provide a 16-bit value of the Active IR output magnitude as obtained by the current sensor measurement.

Active IR UI output (0x17 - 0x18)								
Bit Number	7	6	5	4	3	2	1	0
Data Access	R	R	R	R	R	R	R	R
Name	Active IR UI output low byte							
Bit Number	15	14	13	12	11	10	9	8
Data Access	R	R	R	R	R	R	R	R
Name	Active IR UI output high byte							



5 Hall-effect sensing

5.1 Introduction to Hall-effect sensing

The IQS622 has two internal Hall-effect sensing plates (on chip). No external sensing hardware is required for Hall-effect sensing.

The Hall-effect measurement is essentially a current measurement of the induced current through the Hall-effect-sensor plates produced by the magnetic field passing perpendicular through each plate.

Advanced digital signal processing is performed to provide sensible output data.

- Two threshold levels are provided (prox & touch).
- Hall-effect output is linearized by inverting signals.
- North/South field direction indication provided.
- Differential Hall-Effect sensing:
 - Removes common mode disturbances
 - North-South field indication

5.2 Channel specifications

Channels 5 and 6 are dedicated to Hall-effect sensing. Channel 5 performs the positive direction measurements and channel 6 will handle all measurements in the negative direction. These two channels are used in conjunction to acquire differential Hall-effect data and will always be used as input data to the Hall-effect UI's.

The two Hall-effect channels incorporate:

- Large CS cap usage
- Selectable charge frequency
- **Ch5 – Hall-effect channel 1:**
 - Hall sensing without polarity flip.
- **Ch6 – Hall-effect channel 2:**
 - Hall sensing with polarity flip.

There is a dedicated Hall-effect user interface available:

- a) Hall-effect switch UI

Table 5.1 Hall-effect sensor – channel allocation

Mode	CH0	CH1	CH2	CH3	CH4	CH5	CH6
Hall-effect switch UI						• Positive	• Negative

Key:

- - Optional implementation
- - Fixed use for UI

5.3 Hardware configuration

Rudimentary hardware configurations.

Table 5.2 Hall-effect sensing – hardware description

Axially polarized magnet (linear movement or magnet presence detection)	
Hall-effect push switch	
Smart cover	
Bar magnet (linear movement and magnet field detection)	
Slide switch	



5.4 Software configuration

5.4.1 Registers to configure for Hall-effect sensing:

Table 5.3 Hall-effect sensing settings registers

Address	Name	Description	Recommended setting
0xA0	Hall-effect settings 0	Charge frequency divider and ATI mode settings	Charge frequency adjusts the conversion rate of the Hall-effect channels. Faster conversions consume less current. Full ATI is recommended for fully automated sensor tuning.
0xA1	Hall-effect settings 1	ATI base and target selections	ATI target should be more than ATI base to achieve an ATI
0xB0	Hall-effect switch UI settings	Various settings for the Hall-effect switch UI	None
0xB1	Hall-effect switch UI prox threshold	Prox Threshold for UI	Less than touch threshold
0xB2	Hall-effect switch UI touch threshold	Touch Threshold for UI	None

5.4.2 Example code:

Example code for an Arduino Uno can be downloaded at:

www.azoteq.com/images/stories/software/IQS62x_Demo.zip



5.5 Sensor data output and flags

The following registers can be monitored by the master to detect Hall-effect related events.

- g) The **HALL_EVENT (bit 1)** in the **Global events (0x11)** register are dedicated to Hall-effect related events. This bit will toggle when either one of the three Hall-effect flags is set and is automatically cleared after reading the registers.

Global events (0x11)								
Bit Number	7	6	5	4	3	2	1	0
Data Access	-	R	R	R	R	R	R	R
Name	-	POWER MODE EVENT	SYS EVENT	ACTIVE IR EVENT	ALS EVENT	HALL EVENT	SAR EVENT	PROX SENSE EVENT

- h) The **Hall-effect UI flags (0x19)** register provides the standard two-level activation output (prox = **HALL_POUT** & touch = **HALL_TOUT**) as well as a **HALL_N/S** bit to indicate the magnet polarity orientation.

Hall-effect UI flags (0x19)								
Bit Number	7	6	5	4	3	2	1	0
Data Access	-	-	-	-	-	R	R	R
Name	-	-	-	-	-	HALL TOUT	HALL POUT	HALL N/S

- i) The **Hall-effect UI output (0x1A - 0x1B)** registers provide a 16-bit value of the Hall-effect amplitude detected by the sensor.

Hall-effect UI output (0x1A- 0x1B)								
Bit Number	7	6	5	4	3	2	1	0
Data Access	R	R	R	R	R	R	R	R
Name	Hall-effect UI output low byte							
Bit Number	15	14	13	12	11	10	9	8
Data Access	R	R	R	R	R	R	R	R
Name	Hall-effect UI output high byte							



6 Device clock, power management and mode operation

6.1 Device main oscillator

The IQS622 has a **16MHz** main oscillator (default enabled) to clock all system functionality.

An option exists to reduce the main oscillator to 8MHz. This will result in all system timings, charge transfers and sample rates to be slower by half of the default implementations.

To set this option this:

- As a software setting – Set the System_settings: bit4 = 1, via an I²C command.
- As a permanent setting – Set the OTP option in FG Bank 0: bit2 = 1, using Azoteq USBProg program.

6.2 Device modes

The IQS622 supports the following modes of operation;

- **Normal power mode** (Fixed report rate)
- **Low power mode** (Reduced report rate, no UI execution)
- **Ultra-low power mode** (Only channel 0 is sensed for a prox)
- **Halt mode** (Suspended/disabled)

Note: Auto modes must be disabled to enter or exit halt mode.

The device will automatically switch between the different operating modes by default. However, this Auto mode feature may be disabled by setting the DSBL_AUTO_MODE bit (Power_mode_settings 0xD2: bit5) to confine device operation to a specific power mode. The POWER_MODE bits (Power_mode_settings 0xD2: bit4-3) can then be used to specify the desired mode of operation.

6.2.1 Normal mode

Normal mode is the fully active sensing mode to function at a fixed report rate specified in the Normal power mode report rate (0xD3) register. This 8-bit value is adjustable from 0ms – 255ms in intervals of 1ms.

Note: The device's low power oscillator has an accuracy as specified in section 9.

6.2.2 Low power mode

Low power mode is a reduced sensing mode where all channels are sensed but at a reduced oscillator speed. The sample rate can be specified in the Low power mode report rate (0xD4) register. The 8-bit value is adjustable from 0ms – 255ms in intervals of 1ms. Reduced report rates also reduce the current consumed by the sensor.

Note: The device's low power oscillator has an accuracy as specified in section 9.

6.2.3 Ultra-low power mode

Ultra-low power mode is a reduced sensing mode where only channel 0 is sensed and no other channels or UI code are executed. Set the EN_ULP_MDE bit (Power_mode_settings: bit6) to enable use of the ultra-low power mode. The sample rate can be specified in the Low power mode report rate (0xD5) register. The 8-bit value is adjustable from 0ms – 4sec in intervals of 16ms.

Wake up will occur on prox detection on channel 0.

6.2.4 Halt mode

Halt mode will suspend all sensing and will place the device in a dormant or sleep state. The device requires an I²C command from a master to explicitly change the power mode out of the halt state before any sensor functionality can continue.



6.2.5 Mode time

The mode time is specified in the Auto mode timer (0xD6) register. The 8-bit value is adjustable from 0ms – 2 min in intervals of 500ms.

6.3 System reset

The IQS622 device monitor's system resets and events.

- a) Every device power-on and reset event will set the Show Reset bit (System flags 0x10: bit7) and the master should explicitly clear this bit by writing it active to acknowledge a valid reset.
- b) The system events will also be indicated with the Global events register's SYS bit (Global events 0x11: bit5) if any system event occur such as a reset. This event will continuously trigger until the reset has been acknowledged.



7 Communication

7.1 I²C module specification

The device supports a standard two wire I²C interface with the addition of an RDY (ready interrupt) line. The communications interface of the IQS622 supports the following:

- *Fast-mode (Fm)* standard I²C up to 400kHz.
- Streaming data as well as event mode.
- The master may address the device at any time. If the IQS622 is not in a communication window, the device will return an ACK after which clock stretching may be induced until a communication window is entered. Additional communication checks are included in the main loop to reduce the average clock stretching time.
- The provided interrupt line (RDY) is open-drain active low implementation and indicates a communication window.

7.2 I²C Read

To read from the device a *current address read* can be performed. This assumes that the address-command is already setup as desired.

Current Address Read

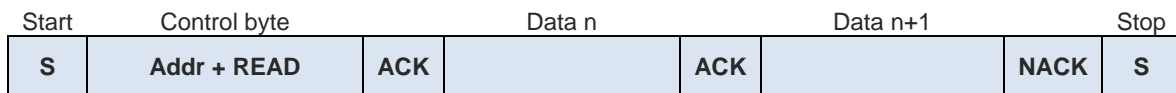

Figure 7.1 Current Address Read

If the address-command must first be specified, then a *random read* must be performed. In this case, a WRITE is initially performed to setup the address-command, and then a repeated start is used to initiate the READ section.

Random Read



Figure 7.2 Random Read

7.3 I²C Write

To write settings to the device a *Data Write* is performed. Here the Address-Command is always required, followed by the relevant data bytes to write to the device.

Data Write



Figure 7.3 I²C Data Write



7.4 Device address and sub-addresses

The default device address is **0x44 = DEFAULT_ADDR**.

Alternative sub-address options are definable in the following one-time programmable bits:
OTP Bank0 (bit3; 0; bit1; bit0) = SUB_ADDR_0 to SUB_ADDR_7

- a) Default address: **0x44 = DEFAULT_ADDR OR SUB_ADDR_0**
- b) Sub-address: **0x45 = DEFAULT_ADDR OR SUB_ADDR_1**
- c) Sub-address: **0x46 = DEFAULT_ADDR OR SUB_ADDR_2**
- d) Sub-address: **0x47 = DEFAULT_ADDR OR SUB_ADDR_3**
- e) Sub-address: **0x4C = DEFAULT_ADDR OR SUB_ADDR_4**
- f) Sub-address: **0x4D = DEFAULT_ADDR OR SUB_ADDR_5**
- g) Sub-address: **0x4E = DEFAULT_ADDR OR SUB_ADDR_6**
- h) Sub-address: **0x4F = DEFAULT_ADDR OR SUB_ADDR_7**

7.5 Additional OTP options

All one-time-programmable device options are located in OTP bank0.

OTP bank0								
Bit Number	7	6	5	4	3	2	1	0
Name	Internal use	COMMS ATI	IR INC DELAY	ALS INC DELAY	SUB ADDRESS (bit3)	8MHz	SUB ADDRESS (bit1-0)	

Bit definitions:

- Bit7: Internal use
 - Do not set. Leave bit cleared.
- Bit 6: Communication mode during ATI
 - 0: No streaming events are generated during ATI
 - 1: Communication continue as setup regardless of ATI state.
- Bit 5: IR increment delay
 - 0: No delay increment
 - 1: Increment delay implemented
- Bit4: ALS increment delay
 - 0: No delay increment
 - 1: Increment delay implemented
- Bit 2: Main Clock frequency selection
 - 0: Run FOSC at 16MHz
 - 1: Run FOSC at 8MHz
- Bit 3,1,0: I2C sub-address
 - I2C address = 0x44 OR SUB_ADDR

7.6 Recommended communication and runtime flow diagram

The following is a basic master program flow diagram to communicate and handle the device. It addresses possible device events such as output events, ATI and system events (resets).

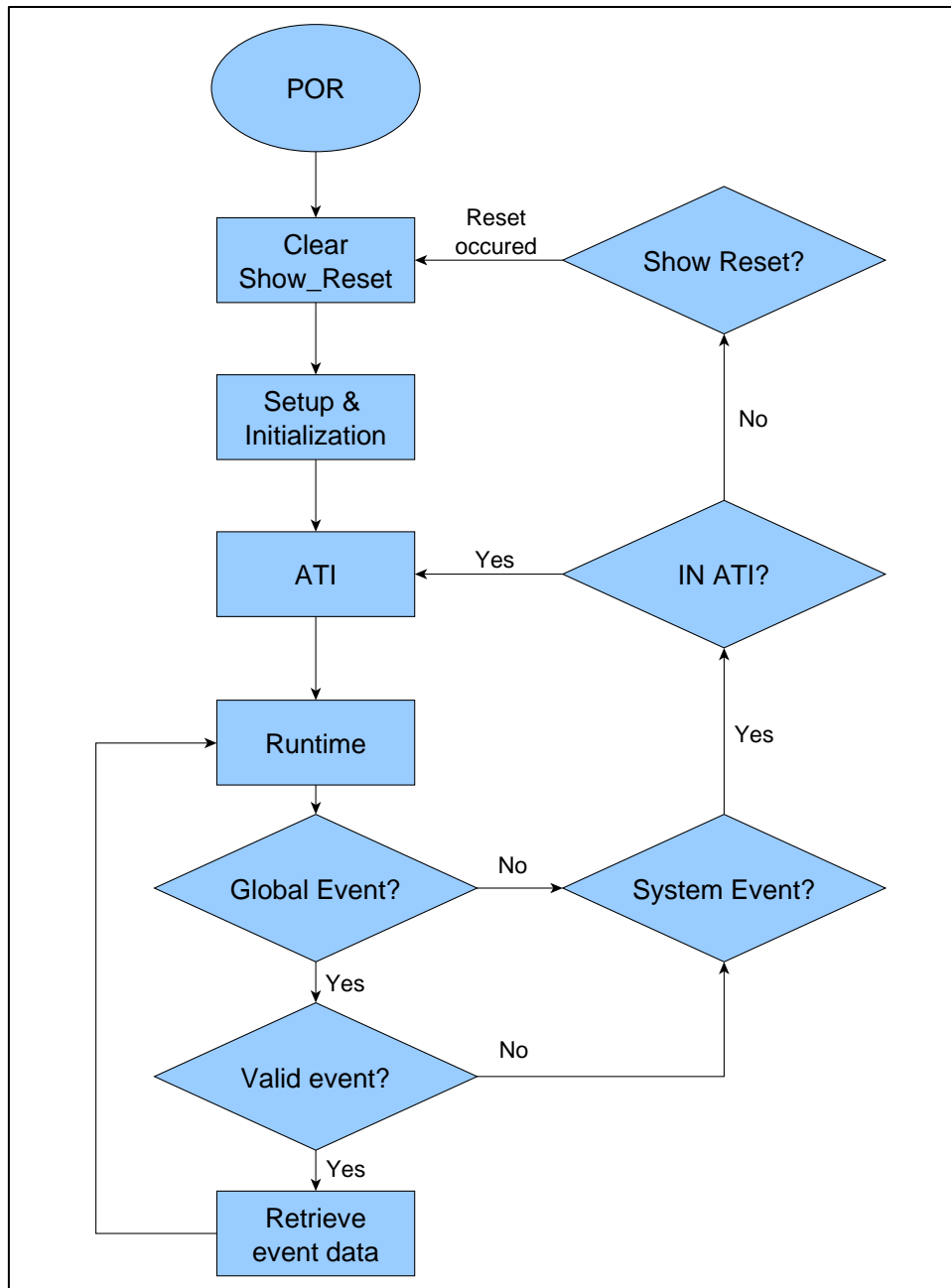

Figure 7.4 Master command structure and runtime event handling flow diagram

It is recommended that the master verifies the status of the System_flags bits to identify events and resets. Detecting either one of these should prompt the master to the next steps of handling the IQS622.

Streaming mode communication is used for detail sensor evaluation during prototyping and/or development phases.

Event mode communication is recommended for runtime use of the IQS622. This reduce the communication on the I²C bus and report only triggered events.



8 Memory map

The full memory map is summarized below. Register groups are explained in the latter subsections.

Table 8.1 IQS622 Memory map index

Full Address	Group Name	Item Name	Data Access	
0x00	Device information data	Product number	Read-Only	
0x01		Software number	Read-Only	
0x02		Hardware number	Read-Only	
0x10	Flags and user interface data	System flags	Read-Only	
0x11		Global events	Read-Only	
0x12		ProxFusion UI flags	Read-Only	
0x13		SAR UI flags	Read-Only	
0x14		ALS UI flags	Read-Only	
0x15		Active IR flags	Read-Only	
0x16		Active IR UI flags	Read-Only	
0x17		Active IR UI output 0	Read-Only	
0x18		Active IR UI output 1	Read-Only	
0x19		Hall-effect UI flags	Read-Only	
0x1A		Hall-effect UI output 0	Read-Only	
0x1B		Hall-effect UI output 1	Read-Only	
0x20		Channel counts (raw data)	Counts Channel 0 low	Read-Only
0x21			Counts Channel 0 high	Read-Only
0x22	Counts Channel 1 low		Read-Only	
0x23	Counts Channel 1 high		Read-Only	
0x24	Counts Channel 2 low		Read-Only	
0x25	Counts Channel 2 high		Read-Only	
0x26	Counts Channel 3 low		Read-Only	
0x27	Counts Channel 3 high		Read-Only	
0x28	Counts Channel 4 low		Read-Only	
0x29	Counts Channel 4 high		Read-Only	
0x2A	Counts Channel 5 low		Read-Only	
0x2B	Counts Channel 5 high		Read-Only	
0x2C	Counts Channel 6 low		Read-Only	
0x2D	Counts Channel 6 high		Read-Only	
0x30	LTA values (filtered data)	LTA Channel 0 low	Read-Only	
0x31		LTA Channel 0 high	Read-Only	
0x32		LTA Channel 1 low	Read-Only	
0x33		LTA Channel 1 high	Read-Only	
0x40	ProxFusion sensor settings	ProxFusion settings 0_0	Read-Write	
0x41		ProxFusion settings 0_1	Read-Write	
0x42		ProxFusion settings 1_0	Read-Write	
0x43		ProxFusion settings 1_1	Read-Write	
0x44		ProxFusion settings 2_0	Read-Write	
0x45		ProxFusion settings 2_1	Read-Write	
0x46		ProxFusion settings 3_0	Read-Write	
0x47		ProxFusion settings 3_1	Read-Write	
0x48		ProxFusion settings 4	Read-Write	
0x49		ProxFusion settings 5	Read-Write	



0x4A		Compensation Ch0	Read-Write
0x4B		Compensation Ch1	Read-Write
0x4C		Multipliers Ch0	Read-Write
0x4D		Multipliers Ch1	Read-Write
0x50	ProxFusion UI settings	Prox threshold Ch0	Read-Write
0x51		Touch threshold Ch0	Read-Write
0x52		Prox threshold Ch1	Read-Write
0x53		Touch threshold Ch1	Read-Write
0x54		ProxFusion discrete UI halt time	Read-Write
0x60	SAR UI settings	SAR UI settings 0	Read-Write
0x61		SAR UI settings 1	Read-Write
0x62		QRD threshold Ch0	Read-Write
0x63		Filter halt threshold Ch0	Read-Write
0x64		Prox threshold Ch0	Read-Write
0x65		QRD halt time	Read-Write
0x70	Light sensor settings	ALS settings 0	Read-Write
0x71		ALS settings 1	Read-Write
0x72		IR settings 0	Read-Write
0x73		IR settings 1	Read-Write
0x74		Multipliers Ch2	Read-Write
0x75		Multipliers Ch3,4	Read-Write
0x90	Active IR UI settings	Active IR UI settings	Read-Write
0x91		Active IR UI prox threshold	Read-Write
0x92		Active IR UI touch threshold	Read-Write
0x93		Ambient light compensation	Read-Write
0xA0	Hall-effect sensor settings	Hall-effect settings 0	Read-Write
0xA1		Hall-effect settings 1	Read-Write
0xA2		Compensation Ch5,6	Read-Write
0xA3		Multipliers Ch5,6	Read-Write
0xB0	Hall-effect switch UI settings	Hall-effect switch UI settings	Read-Write
0xB1		Hall-effect switch UI prox threshold	Read-Write
0xB2		Hall-effect switch UI touch threshold	Read-Write
0xD0	Device and power mode settings	System settings	Read-Write
0xD1		Active channels	Read-Write
0xD2		Power mode settings	Read-Write
0xD3		Normal power mode report rate	Read-Write
0xD4		Low power mode report rate	Read-Write
0xD5		Ultra-low power mode report rate	Read-Write
0xD6		Auto mode timer	Read-Write
0xD7		Global event mask	Read-Write



8.2 Device Information data

8.2.1 Product number

Product number (0x00)								
Bit Number	7	6	5	4	3	2	1	0
Data Access	R	R	R	R	R	R	R	R
Name	Device product number							

Bit definitions:

- Bit 7-0: Device product number = 0x42 = D'66'

8.2.2 Software number

Software number (0x01)								
Bit Number	7	6	5	4	3	2	1	0
Data Access	R	R	R	R	R	R	R	R
Name	Device software number							

Bit definitions:

- Bit 7-0: Device software number = 0x06 = D'06'

8.2.3 Hardware number

Hardware number (0x02)								
Bit Number	7	6	5	4	3	2	1	0
Data Access	R	R	R	R	R	R	R	R
Name	Device hardware number							

Bit definitions:

- Bit 7-0: Device hardware number = 0x83 = D'131'



8.3 Flags and user interface data

8.3.1 System flags

System flags (0x10)								
Bit Number	7	6	5	4	3	2	1	0
Data Access	R	-	-	R	R	R	R	R
Name	SHOW RESET	-	-	POWER MODE		IN ATI	EVENT	NP SEG ACTIVE

Bit definitions:

- Bit 7: Reset indicator
 - 0: No reset event
 - 1: A device reset has occurred and needs to be acknowledged.
- Bit 3-4: Current power mode indicator
 - 00: Normal Mode
 - 01: Low Power Mode
 - 10: Ultra-Low Power Mode
 - 11: Halt Mode
- Bit 2: ATI busy indicator
 - 0: No channels are in ATI
 - 1: One or more channels are in ATI
- Bit 1: Global event indicator
 - 0: No new event to service
 - 1: An event has occurred and should be serviced
- Bit 0: Normal power segment indicator
 - 0: Not performing a normal power update
 - 1: Busy performing a normal power update

8.3.2 Global events

Global events (0x11)								
Bit Number	7	6	5	4	3	2	1	0
Data Access	-	R	R	R	R	R	R	R
Name	-	POWER MODE EVENT	SYS EVENT	ACTV IR EVENT	ALS EVENT	HALL EVENT	SAR EVENT	PROX SENSE EVENT

Bit definitions:

- Bit 6: Power mode event flag
 - 0: No event to report
 - 1: A power mode event has occurred and should be handled
- Bit 5: System event flag
 - 0: No event to report
 - 1: A system event has occurred and should be handled
- Bit 4: Active IR event flag
 - 0: No event to report
 - 1: An active IR event has occurred and should be handled
- Bit 3: ALS detect event flag
 - 0: No event to report
 - 1: An ALS detect event has occurred and should be handled
- Bit 2: Hall-effect event flag



- 0: No event to report
- 1: A Hall-effect event has occurred and should be handled
- Bit 1: SAR event flag
 - 0: No event to report
 - 1: A SAR event has occurred and should be handled
- Bit 0: ProxSense event flag
 - 0: No event to report
 - 1: A capacitive event has occurred and should be handled

8.3.3 ProxSense UI flags

ProxSense UI flags (0x12)								
Bit Number	-	-	5	4	-	-	1	0
Data Access	-	-	R	R	-	-	R	R
Name	-	-	CH1_T	CH0_T	-	-	CH1_P	CH0_P

Bit definitions:

- Bit 5: Ch1 touch indicator
 - 0: Delta below touch threshold
 - 1: Delta above touch threshold
- Bit 4: Ch0 touch indicator
 - 0: Delta below touch threshold
 - 1: Delta above touch threshold
- Bit 1: Ch1 prox indicator
 - 0: Delta below prox threshold
 - 1: Delta above prox threshold
- Bit 0: Ch0 prox indicator
 - 0: Delta below prox threshold
 - 1: Delta above prox threshold

8.3.4 SAR UI flags

SAR UI flags (0x13)								
Bit Number	7	6	5	4	3	2	1	0
Data Access	-	-	-	R	-	R	R	R
Name	-	-	-	SAR ACTIVE		QUICK RELEASE	MOVEMENT	FHALT

Bit definitions:

- Bit 4: SAR Standoff Active
 - 0: SAR condition inactive
 - 1: SAR condition active
- Bit 2: Quick release detection indicator
 - 0: Quick release not detected
 - 1: Quick release detected
- Bit 1: Movement indicator
 - 0: Movement not detected
 - 1: Movement detected
- Bit 0: Filter halt indicator
 - 0: Delta below filter halt level
 - 1: Delta above filter halt level



8.3.5 ALS UI flags

ALS UI flags (0x14)								
Bit Number	7	6	5	4	3	2	1	0
Data Access	-	-	-	-	R	R	R	R
Name	-	Reserved			ALS range value			

Bit definitions:

- Bit 3-0: ALS range value

8.3.6 Active IR flags

Active IR flags (0x15)								
Bit Number	7	6	5	4	3	2	1	0
Data Access	-	-	-	-	R	R	R	R
Name	Reserved				IR range value			

Bit definitions:

- Bit 3-0: IR range value

8.3.7 Active IR UI flags

Active IR UI flags (0x16)								
Bit Number	7	6	5	4	3	2	1	0
Data Access	-	-	-	-	-	-	R	R
Name	-	-	-	-	-	-	TOUCH	PROX

Bit definitions:

- Bit 1: Active IR touch indicator
 - 0: No Active IR touch condition
 - 1: Active IR in touch
- Bit 0: Active IR prox indicator
 - 0: No Active IR prox condition
 - 1: Active IR in prox

8.3.8 Active IR UI output

Active IR UI output (0x17/0x18)								
Bit Number	7	6	5	4	3	2	1	0
Data Access	R	R	R	R	R	R	R	R
Name	Active IR UI output low byte							
Bit Number	15	14	13	12	11	10	9	8
Data Access	R	R	R	R	R	R	R	R
Name	Active IR UI output high byte							

Bit definitions:

- Bit 15-0: Active IR UI output



8.3.9 Hall-effect UI flags

Hall-effect UI flags (0x19)								
Bit Number	7	6	5	4	3	2	1	0
Data Access	-	-	-	-	-	R	R	R
Name	-	-	-	-	-	TOUCH	PROX	HALL N/S

Bit definitions:

- Bit 2: Hall-effect touch indicator
 - 0: Field strength below touch threshold
 - 1: Field strength above touch threshold
- Bit 1: Hall-effect prox indicator
 - 0: Field strength below prox threshold
 - 1: Field strength above prox threshold
- Bit 0: Hall-effect North South field indication
 - 0: North field present
 - 1: South field present

8.3.10 Hall-effect UI output

Hall-effect UI output (0x1A - 0x1B)								
Bit Number	7	6	5	4	3	2	1	0
Data Access	R	R	R	R	R	R	R	R
Name	Hall-effect UI output low byte							
Bit Number	15	14	13	12	11	10	9	8
Data Access	R	R	R	R	R	R	R	R
Name	Hall-effect UI output high byte							

Bit definitions:

- Bit 15-0: Hall-effect UI output



8.4 Channel counts (raw data)

Channel counts Ch0/1/2/3/4/5/6 (0x20/0x21-0x2C/0x2D)								
Bit Number	7	6	5	4	3	2	1	0
Data Access	R	R	R	R	R	R	R	R
Name	Channel counts low byte							
Bit Number	15	14	13	12	11	10	9	8
Data Access	R	R	R	R	R	R	R	R
Name	Channel counts high byte							

Bit definitions:

- Bit 15-0: AC filter or raw value

8.5 LTA values (filtered data)

LTA Ch0/1 (0x30/0x31-0x32/0x33)								
Bit Number	7	6	5	4	3	2	1	0
Data Access	R	R	R	R	R	R	R	R
Name	LTA low byte							
Bit Number	15	14	13	12	11	10	9	8
Data Access	R	R	R	R	R	R	R	R
Name	LTA high byte							

Bit definitions:

- Bit 15-0: LTA filter value



8.6 ProxFusion sensor settings

8.6.1 ProxFusion settings 0

8.6.1.1 Capacitive sensing

ProxFusion settings 0_0/1 (0x40-0x41)								
Bit Number	7	6	5	4	3	2	1	0
Data Access	R/W	R/W	-	R/W	R/W	R/W	R/W	R/W
Name	Sensor mode		-	PROJ / SELF	TX Select		RX Select	
Fixed value	0	0	0					

Bit definitions:

- Bit 7-6: Sensor Mode
 - 00: ProxSense mode
- Bit 4: PROJ/SELF
 - 0: Self-capacitive mode is used
 - 1: Projected-capacitive mode is used
- Bit 3-2: TX Select
 - 00: TX 0 and TX 1 is disabled
 - 01: TX 0 is enabled
 - 10: TX 1 is enabled
 - 11: TX 0 and TX 1 is enabled
- Bit 1-0: RX Select
 - 00: RX 0 and RX 1 is disabled
 - 01: RX 0 is enabled
 - 10: RX 1 is enabled
 - 11: RX 0 and RX 1 is enabled

8.6.2 ProxFusion settings 1

8.6.2.1 Capacitive sensing

ProxFusion settings 1_0/1 (0x42-0x43)								
Bit Number	7	6	5	4	3	2	1	0
Data Access	-	R/W	R/W	R/W	R/W	R/W	R/W	R/W
Name	-	CSz	CHARGE FREQ		PROJ BIAS		AUTO_ATI_MODE	
Default	0x67							
	0	1	1	0	0	1	1	1

Bit definitions:

- Bit 6: CS size
 - 0: Prox storage capacitor size is 15pF
 - 1: Prox storage capacitor size is 60pF
- Bit 5-4: Charge frequency divider
 - 00: 1/2
 - 01: 1/4
 - 10: 1/8
 - 11: 1/16
- Bit 3-2: Projected bias
 - 00: 2.5µA
 - 01: 5µA
 - 10: 10µA
 - 11: 20µA
- Bit 1-0: Auto ATI Mode
 - 00: ATI disabled



- 01: Partial ATI (all multipliers are fixed)
- 10: Semi-Partial ATI (only coarse multipliers are fixed)
- 11: Full-ATI

8.6.3 ProxFusion settings 2

8.6.3.1 Capacitive sensing

ProxFusion settings 2_0/1 (0x44-0x45)								
Bit Number	7	6	5	4	3	2	1	0
Data Access	R/W	R/W	R/W	R/W	R/W	R/W	R/W	R/W
Name	ATI_BASE		ATI_TARGET (x32)					
Default	0xD0							
	1	1	0	1	0	0	0	0

Bit definitions:

- Bit 7-6: Auto ATI base value
 - 00: 75
 - 01: 100
 - 10: 150
 - 11: 200
- Bit 5-0: Auto ATI Target
 - ATI Target is 6-bit value x 32

8.6.4 ProxFusion settings 3

8.6.4.1 Capacitive sensing

ProxFusion settings 3_0/1 (0x46-0x47)								
Bit Number	7	6	5	4	3	2	1	0
Data Access	R/W	R/W	R/W	-	R/W	R/W	R/W	-
Name	UP LENGTH SELECT		CS DIV	Internal use	UP LENGTH EN	PASS LENGTH SELECT		-
Default	0x06							
	0	0	0	0	0	1	1	0

Bit definitions:

- Bit 7-6: Up Length Select
 - 00: Up length = 0010
 - 01: Up length = 0110
 - 10: Up length = 1010
 - 11: Up length = 1110
- Bit 5: CS divider
 - 0: CS divider disabled
 - 1: CS divider enabled
- Bit 3: Up length increase enable
 - 0: Up length select is disabled
 - 1: Up length select is enabled (value in bit 7-6 is used)
- Bit 2-1: Pass Length Select
 - 00: Pass length = 001
 - 01: Pass length = 011
 - 10: Pass length = 101
 - 11: Pass length = 111



8.6.5 ProxFusion settings 4

8.6.5.1 Capacitive sensing

ProxFusion settings 4 (0x48)								
Bit Number	7	-	5	4	3	2	1	0
Data Access	R/W	-	R/W	R/W	R/W	R/W	R/W	R/W
Name	SAR EN	-	TWO SIDED EN	ACF DISABLE	LTA BETA		ACF BETA	
Default	0x00							
	0	0	0	0	0	0	0	0

Bit definitions:

- Bit 7: SAR UI Enable
 - 0: SAR UI is disabled
 - 1: SAR UI is enabled
- Bit 5: Two-sided Detection
 - 0: Bidirectional detection disabled
 - 1: Bidirectional detection enabled
- Bit 4: Disable AC Filter
 - 0: AC Filter Enabled
 - 1: AC Filter Disabled
- Bit 3-2: Long Term Average Beta Value
 - 00: 7
 - 01: 8
 - 10: 9
 - 11: 10
- Bit 1-0: AC Filter Beta Value
 - 00: 1
 - 01: 2
 - 10: 3
 - 11: 4

8.6.6 ProxFusion settings 5

ProxFusion settings 5 (0x49)								
Bit Number	7	6	5	4	3	2	1	0
Data Access	-	-	-	R/W	R/W	R/W	R/W	R/W
Name	Internal use							
Default	0x01							
	0	0	0	0	0	0	0	1

Bit definitions:

- Bit 7-0: Internal use



8.6.7 Compensation Ch0/1

Compensation Ch0/1 (0x4A-0x4B)								
Bit Number	7	6	5	4	3	2	1	0
Data Access	R/W	R/W	R/W	R/W	R/W	R/W	R/W	R/W
Name	Compensation (7-0)							

Bit definitions:

- Bit 7-0: Compensation lower 8-bits
 - 0-255: Lower 8-bits of the compensation value.

8.6.8 Multipliers Ch0/1

Multipliers Ch0/1 (0x4C-0x4D)								
Bit Number	7	6	5	4	3	2	1	0
Data Access	R/W	R/W	R/W	R/W	R/W	R/W	R/W	R/W
Name	COMPENSATION (9-8)		MULTIPLIERS COARSE		MULTIPLIERS FINE			

Bit definitions:

- Bit 7-6: Compensation upper two bits
 - 0-3: Upper 2-bits of the compensation value.
- Bit 5-4: Multiplier coarse
 - 0-3: Coarse multiplier selection
- Bit 3-0: Multiplier fine
 - 0-15: Fine multiplier selection



8.7 ProxFusion UI settings

8.7.1 Prox threshold Ch0/1

Prox threshold Ch0/1 (0x50/0x52)								
Bit Number	7	6	5	4	3	2	1	0
Data Access	R/W	R/W	R/W	R/W	R/W	R/W	R/W	R/W
Name	Prox threshold value							
Default	0x16 = D'22							
	0	0	0	1	0	1	1	0

Bit definitions:

- Bit 7-0: Prox threshold = Prox threshold value
 - 0-255: Prox threshold value

8.7.2 Touch threshold Ch0/1

Touch threshold Ch0/1 (0x51/0x53)								
Bit Number	7	6	5	4	3	2	1	0
Data Access	R/W	R/W	R/W	R/W	R/W	R/W	R/W	R/W
Name	Touch Threshold Value							
Default	0x25 = D'37							
	0	0	1	0	0	1	0	1

Bit definitions:

- Bit 7-0: Touch threshold = Touch threshold value * LTA / 256
 - 0-255: Touch threshold value

8.7.3 ProxFusion discrete UI halt time

ProxFusion discrete UI halt time (0x54)								
Bit Number	7	6	5	4	3	2	1	0
Data Access	R/W	R/W	R/W	R/W	R/W	R/W	R/W	R/W
Name	Halt time							
Default	0x28 = D'40 = 20sec							
	0	0	1	0	1	0	0	0

Bit definitions:

- Bit 7-0: Halt time in 500ms increments (decimal value x 500ms)
 - 0-127sec: ProxFusion discrete UI halt time
 - 0xFF = 255: Never halt



8.8 SAR UI settings

8.8.1 SAR setting 0

SAR settings 0 (0x60)								
Bit Number	7	6	5	4	3	2	1	0
Data Access	-	R/W	R/W	R/W	-	R/W	R/W	R/W
Name	-	Quick release beta			-	Movement beta		
Default	0x16							
	0	0	0	1	0	1	1	0

Bit definitions:

- Bit 6-4: Quick release detection beta
 - 0-7: Quick release detection filter beta value
- Bit 2-0: Movement detection filter beta
 - 0-7: Movement filter beta value

8.8.2 SAR settings 1

SAR settings 1 (0x61)								
Bit Number	7	6	5	4	3	2	1	0
Data Access	R/W	R/W	R/W	R/W	R/W	R/W	R/W	R/W
Name	LTA halt timeout in no prox				Movement detection threshold			
Default	1sec				D'5			
	0	0	1	0	0	1	0	1

Bit definitions:

- Bit 7-4: LTA halt timeout in no prox
 - 0-15: LTA halt timeout in no prox in 500ms increments (decimal value * 500ms)
- Bit 3-0: Movement detection threshold
 - 0-15: Movement threshold = Movement threshold value

8.8.3 Quick release detection threshold

Quick release detection threshold (0x62)								
Bit Number	7	6	5	4	3	2	1	0
Data Access	R/W	R/W	R/W	R/W	R/W	R/W	R/W	R/W
Name	QRD threshold value							
Default	0x05							
	0	0	0	0	0	1	0	1

Bit definitions:

- Bit 7-0: QRD threshold = QRD threshold value
 - 0-255: QRD threshold value



8.8.4 Filter halt threshold

SAR filter halt threshold (0x63)								
Bit Number	7	6	5	4	3	2	1	0
Data Access	R/W	R/W	R/W	R/W	R/W	R/W	R/W	R/W
Name	Filter halt threshold value							
Default	0x16 = D'22							
	0	0	0	1	0	1	1	0

Bit definitions:

- Bit 7-0: Filter halt threshold = Filter halt threshold value
 - 0-255: SAR filter halt threshold value

8.8.5 SAR prox threshold

SAR prox threshold Ch0 (0x64)								
Bit Number	7	6	5	4	3	2	1	0
Data Access	R/W	R/W	R/W	R/W	R/W	R/W	R/W	R/W
Name	SAR prox threshold value							
Default	0x25 = D'37							
	0	0	1	0	0	1	0	1

Bit definitions:

- Bit 7-0: SAR prox threshold = SAR prox threshold value
 - 0-255: SAR prox threshold value

8.8.6 Quick release detection halt time

Quick release detection halt time (0x65)								
Bit Number	7	6	5	4	3	2	1	0
Data Access	R/W	R/W	R/W	R/W	R/W	R/W	R/W	R/W
Name	LTA halt timeout after a QRD (decimal value x 500ms)							
Default	0x28 = D'40 = 20sec							
	0	0	1	0	1	0	0	0

Bit definitions:

- Bit 7-0: LTA halt timeout after a Quick release detection with no movement afterwards (decimal value x 500ms)
 - 0x00 – 0xFE = 0 – 127 seconds: QRD halt timeout
 - 0xFF = 255 = Never timeout



8.9 Light sensor settings

8.9.1 ALS settings 0

ALS settings 0 (0x70)								
Bit Number	7	6	5	4	3	2	1	0
Data Access	R/W	-	R/W	R/W	R/W	R/W	-	-
Name	Fast Filter	Internal use	CHARGE FREQ		Internal use	CSz	-	-
Default	0x04							
	0	0	0	0	0	1	0	0

Bit definitions:

- Bit 7: Fast filter speed select
 - 0: Window length is 10 samples
 - 1: Window length is 4 samples
- Bit 5-4: Charge frequency divider
 - 00: 1/2
 - 01: 1/4
 - 10: 1/8
 - 11: 1/16
- Bit 3: Internal use
 - Leave cleared (bit 3 = 0)
- Bit 2: CS size
 - 0: Prox storage capacitor size is 15pF
 - 1: Prox storage capacitor size is 60pF

8.9.2 ALS settings 1

ALS settings 1 (0x71)								
Bit Number	7	6	5	4	3	2	1	0
Data Access	R/W	R/W	R/W	R/W	R/W	R/W	R/W	R/W
Name	ATI Target (x32)						Multiplier calibration	
Default	0x80							
	1	0	0	0	0	0	0	0

Bit definitions:

- Bit 7-2: ATI Target for ALS ch2 & 3
 - 0 – 64: ATI target = ATI target value * 32
- Bit 1-0: Multiplier calibration
 - 0-3: Fine multiplier factor calibration for ALS



8.9.3 IR settings 0

IR settings 0 (0x72)								
Bit Number	7	6	5	4	3	2	1	0
Data Access	R/W	R/W	R/W	R/W	R/W	R/W	R/W	R/W
Name	Fast Filter	Internal use	CHARGE FREQ		Internal use	CSz	ACTV IR GAIN	
Default	0x04							
	0	0	0	0	0	1	0	0

Bit definitions:

- Bit 7: Fast filter speed select
 - 0: Window length is 5 samples
 - 1: Window length is 2 samples
- Bit 5-4: Charge frequency divider
 - 00: 1/2
 - 01: 1/4
 - 10: 1/8
 - 11: 1/16
- Bit 3: Internal use
 - Leave bit cleared (bit 3 = 0)
- Bit 2: CS size
 - 0: Prox storage capacitor size is 15 pF
 - 1: Prox storage capacitor size is 60 pF
- Bit 1-0: Active IR Gain base value
 - 0-3: Compensation = (ACTV IR GAIN + ALS Range Value) * 2

8.9.4 IR settings 1

IR settings 1 (0x73)								
Bit Number	7	6	5	4	3	2	1	0
Data Access	R/W	R/W	R/W	R/W	R/W	R/W	R/W	R/W
Name	ATI Target (x32)						Multiplier calibration	
Default	0x40							
	0	1	0	0	0	0	0	0

Bit definitions:

- Bit 7-2: ATI Target for IR channel 3 & 4
 - 0 – 64: ATI target = ATI target value * 32
- Bit 1-0: Multiplier calibration
 - 0-3: Fine multiplier factor calibration for IR



8.9.5 Multipliers Ch2

Multipliers Ch2 (0x74)								
Bit Number	7	6	5	4	3	2	1	0
Data Access	R/W	R/W	R/W	R/W	R/W	R/W	R/W	R/W
Name	-		MULTIPLIER COARSE		MULTIPLIER FINE			
Default	0x00							
	0	0	0	0	0	0	0	0

Bit definitions:

- Bit 5-4: Multiplier coarse
 - 0-4: Coarse multiplier selection
- Bit 3-0: Multiplier fine
 - 0-15: Fine multiplier selection

8.9.6 Multipliers Ch3/4

Multipliers Ch3_Ch4 (0x75)								
Bit Number	7	6	5	4	3	2	1	0
Data Access	R/W	R/W	R/W	R/W	R/W	R/W	R/W	R/W
Name	-		MULTIPLIER COARSE		MULTIPLIER FINE			
Default	0x00							
	0	0	0	0	0	0	0	0

Bit definitions:

- Bit 5-4: Multiplier coarse
 - 0-4: Coarse multiplier selection
- Bit 3-0: Multiplier fine
 - 0-15: Fine multiplier selection



8.10 Active IR UI settings

8.10.1 Active IR UI settings

Active IR UI settings (0x90)								
Bit Number	7	6	5	4	3	2	1	0
Data Access	-	-	R/W	R/W	-	-	R/W	R/W
Name	-	-	Hysteresis_T		-	-	Hysteresis_P	
Default	0x11							
	0	0	0	1	0	0	0	1

Bit definitions:

- Bit 5-4: Touch Hysteresis
 - 00: Disabled
 - 01: 1/4 of threshold
 - 10: 1/8 of threshold
 - 11: 1/16 of threshold
- Bit 1-0: Prox Hysteresis
 - 00: Disabled
 - 01: 1/4 of threshold
 - 10: 1/8 of threshold
 - 11: 1/16 of threshold

8.10.2 Active IR UI prox threshold

Active IR UI prox threshold (0x91)								
Bit Number	7	6	5	4	3	2	1	0
Data Access	R/W	R/W	R/W	R/W	R/W	R/W	R/W	R/W
Name	IR prox threshold value							
Default	0x19 = D'25							
	0	0	0	1	1	0	0	1

Bit definitions:

- Bit 7-0: IR prox threshold = IR prox threshold value
 - 0-255: IR prox threshold value

8.10.3 Active IR UI touch threshold

Active IR UI touch threshold (0x92)								
Bit Number	7	6	5	4	3	2	1	0
Data Access	R/W	R/W	R/W	R/W	R/W	R/W	R/W	R/W
Name	IR touch threshold value							
Default	0x19 = D'25 * 4 = 100							
	0	0	0	1	1	0	0	1

Bit definitions:

- Bit 7-0: IR touch threshold = IR touch threshold value * 4
 - 0-1020: IR touch threshold



8.10.4 Ambient light compensation

Ambient light compensation (0x93)								
Bit Number	7	6	5	4	3	2	1	0
Data Access	R/W	R/W	R/W	R/W	R/W	R/W	R/W	R/W
Name	Ambient light compensation value							
Default	0x00 = D'0							
	0	0	0	0	0	0	0	0

Bit definitions:

- Bit 7-0: Ambient light compensation = Ambient light compensation value
 - 0-255: Ambient light compensation value



8.11 Hall-effect sensor settings

8.11.1 Hall-effect settings 0

Hall-effect settings 0 (0xA0)								
Bit Number	7	6	5	4	3	2	1	0
Data Access	-	-	R/W	R/W	-	-	R/W	R/W
Name	-	-	CHARGE_FREQ		reserved		AUTO_ATI_MODE	
Default	0x03							
	0	0	0	0	0	0	1	1

Bit definitions:

- Bit 5-4: Charge frequency divider
 - 00: 1/2
 - 01: 1/4
 - 10: 1/8
 - 11: 1/16
- Bit 1-0: Auto ATI Mode
 - 00: ATI disabled
 - 01: Partial ATI (all multipliers are fixed)
 - 10: Semi-Partial ATI (only coarse multipliers are fixed)
 - 11: Full-ATI

8.11.2 Hall-effect setting 1

Hall-effect settings 1 (0xA1)								
Bit Number	7	6	5	4	3	2	1	0
Data Access	R/W	R/W	R/W	R/W	R/W	R/W	R/W	R/W
Name	ATI_BASE		ATI_TARGET (x32)					
Default	0x50							
	0	0	0	0	0	1	0	1

Bit definitions:

- Bit 7-6: Auto ATI base value
 - 00: 75
 - 01: 100
 - 10: 150
 - 11: 200
- Bit 5-0: Auto ATI target
 - ATI target is 6-bit value x 32



8.11.3 Compensation Ch5/6

Compensation Ch5/6 (0xA2)								
Bit Number	7	6	5	4	3	2	1	0
Data Access	R/W	R/W	R/W	R/W	R/W	R/W	R/W	R/W
Name	Compensation (0-7)							

Bit definitions:

- Bit 7-0: Compensation lower 8-bits
 - 0-255: Lower 8-bits of the compensation value.

8.11.4 Multipliers Ch5/6

Multipliers Ch5/6 (0xA3)								
Bit Number	7	6	5	4	3	2	1	0
Data Access	R/W	R/W	R/W	R/W	R/W	R/W	R/W	R/W
Name	COMPENSATION (8-9)		MULTIPLIERS COARSE		MULTIPLIERS FINE			

Bit definitions:

- Bit 7-6: Compensation (8-9)
 - 0-3: Upper 2-bits of the Compensation value.
- Bit 5-4: Multiplier coarse
 - 0-3: Coarse multiplier selection
- Bit 3-0: Multiplier fine
 - 0-15: Fine multiplier selection.



8.12 Hall-effect switch UI settings

8.12.1 Hall-effect switch UI settings

Hall-effect switch UI settings (0xB0)								
Bit Number	7	6	5	4	3	2	1	0
Data Access	-	R/W	R/W	R/W	-	R/W	R/W	R/W
Name	-	Linear Mode	Hysteresis_T		-	Swap Direction	Hysteresis_P	
Default	0x00							
	0	0	0	0	0	0	0	0

Bit definitions:

- Bit 6: Linearize Output
 - 0: Disabled
 - 1: Enabled
- Bit 5-4: Touch Hysteresis
 - 00: Disabled
 - 01: 1/4 of threshold
 - 10: 1/8 of threshold
 - 11: 1/16 of threshold
- Bit 2: Swap field direction indication
 - 0: Disabled
 - 1: Enabled
- Bit 1-0: Prox Hysteresis
 - 00: Disabled
 - 01: 1/4 of threshold
 - 10: 1/8 of threshold
 - 11: 1/16 of threshold

8.12.2 Hall-effect switch UI prox threshold

Hall-effect switch UI prox threshold (0xB1)								
Bit Number	7	6	5	4	3	2	1	0
Data Access	R/W	R/W	R/W	R/W	R/W	R/W	R/W	R/W
Name	Hall-effect prox threshold value							
Default	0x19							
	0	0	0	1	1	0	0	1

Bit definitions:

- Bit 7-0: Hall-effect prox threshold = Hall-effect prox threshold value
 - 0-255: Hall-effect prox threshold value

8.12.3 Hall-effect switch UI touch threshold

Hall-effect switch UI touch threshold (0xB2)								
Bit Number	7	6	5	4	3	2	1	0
Data Access	R/W	R/W	R/W	R/W	R/W	R/W	R/W	R/W
Name	Hall-effect touch threshold value							
Default	0x19							
	0	0	0	1	1	0	0	1

Bit definitions:

- Bit 7-0: Hall-effect touch threshold = Hall-effect touch threshold value * 4
 - 0-1020: Hall-effect touch threshold



8.13 Device and power mode settings

8.13.1 System settings

System settings (0xD0)								
Bit Number	7	6	5	4	3	2	1	0
Data Access	W=1	W=1	R/W	R/W	R/W	R/W	W=1	W=1
Name	SOFT RESET	ACK RESET	EVENT MODE	8MHz	COMMS ATI	ATI BAND	REDO ATI	RESEED
Default	0x08							
	0	0	0	0	1	0	0	0

Bit definitions:

- Bit 7: Software Reset (**Set only, will clear when done**)
 - 1: Causes the device to perform a WDT reset
- Bit 6: ACK Reset (**Set only, will clear when done**)
 - 1: Acknowledge that a reset has occurred. This event will trigger until acknowledged.
- Bit 5: Event mode enable
 - 0: Event mode disabled. Default streaming mode communication.
 - 1: Event mode communication enabled.
- Bit 4: Main Clock frequency selection
 - 0: Run FOSC at 16MHz
 - 1: Run FOSC at 8MHz
- Bit 3: Communications during ATI
 - 0: No communications are generated during ATI
 - 1: Communication continue as setup regardless of ATI state.
- Bit 2: Re-ATI Band selection
 - 0: Re-ATI when outside 1/8 of ATI target
 - 1: Re-ATI when outside 1/16 of ATI target
- Bit 1: Redo ATI on all channels (**Set only, will clear when done**)
 - 1: Redo the ATI on all channels
- Bit 0: Reseed all Long-term filters (**Set only, will clear when done**)
 - 1: Reseed all channels

8.13.2 Active channels

Active channels (0xD1)								
Bit Number	7	6	5	4	3	2	1	0
Data Access	-	R/W	R/W	R/W	R/W	R/W	R/W	R/W
Name	-	Ch6	Ch5	Ch4	Ch3	Ch2	Ch1	Ch0
Default	0x7F							
	0	1	1	1	1	1	1	1

Bit definitions:

- Bit 6: Ch6 (**note: Ch5 and Ch6 must both be enabled for Hall-effect switch UI to be functional**)
 - 0: Channel is disabled
 - 1: Channel is enabled



- Bit 5: Ch5 (*note: Ch5 and Ch6 must both be enabled for Hall-effect switch UI to be functional*)
 - 0: Channel is disabled
 - 1: Channel is enabled
- Bit 4: Ch4 (*note: Ch3 and Ch4 must both be enabled for Active IR UI to be functional*)
 - 0: Channel is disabled
 - 1: Channel is enabled
- Bit 3: Ch3 (*note: Ch3 and Ch4 must both be enabled for Active IR UI to be functional*)
 - 0: Channel is disabled
 - 1: Channel is enabled
- Bit 2: Ch2 (*note: Ch2 must be enabled for ALS UI to be functional*)
 - 0: Channel is disabled
 - 1: Channel is enabled
- Bit 1: Ch1
 - 0: Channel is disabled
 - 1: Channel is enabled
- Bit 0: Ch0
 - 0: Channel is disabled
 - 1: Channel is enabled

8.13.3 Power mode settings

Power mode settings 0 (0xD2)								
Bit Number	7	6	5	4	3	2	1	0
Data Access	R/W	R/W	R/W	R/W	R/W	R/W	R/W	R/W
Name	NP SEG ALL	EN ULP MODE	DSBL AUTO MODE	POWER MODE		NP SEG RATE		
Default	0x03							
	0	0	0	0	0	0	1	1

Bit definitions:

- Bit 7: Normal power segment bounds check
 - 0: NP-segment check on prox channel 0 only
 - 1: NP-segment check on all channels
- Bit 6: Allow auto ultra-low power mode switching
 - 0: ULP is disabled during auto-mode switching
 - 1: ULP is enabled during auto-mode switching
- Bit 5: Disable auto mode switching
 - 0: Auto mode switching is enabled
 - 1: Auto mode switching is disabled
- Bit 4-3: Manually select power mode (*note: bit 5 must be set*)
 - 00: Normal power mode. The device runs at the normal power rate, all enabled channels and UIs will execute.
 - 01: Low power mode. The device runs at the low power rate, all enabled channels and UIs will execute.
 - 10: Ultra-low power mode. The device runs at the ultra-low power rate, Ch0 is run as wake-up channel. The other channels execute at the NP-segment rate.
 - 11: Halt mode. No conversions are performed; the device must be removed from this mode using an I2C command.
- Bit 2-0: Normal power segment update rate
 - 000: 1/2 ULP rate
 - 001: 1/4 ULP rate
 - 010: 1/8 ULP rate
 - 011: 1/16 ULP rate
 - 100: 1/32 ULP rate
 - 101: 1/64 ULP rate
 - 110: 1/128 ULP rate
 - 111: 1/256 ULP rate



8.13.4 Normal power mode report rate

Normal power mode report rate (0xD3)								
Bit Number	7	6	5	4	3	2	1	0
Data Access	R/W	R/W	R/W	R/W	R/W	R/W	R/W	R/W
Name	Normal power mode report rate in ms							
Default	0x0C = D'12 = 12ms							
	0	0	0	0	1	1	0	0

Bit definitions:

- Bit 7-0: Normal mode report rate in ms (**note: LPOSC timer has ± 4ms accuracy**)
 - 0-255ms: Normal mode report rate

Please note: Report rates faster than 4ms can be delayed due to channel setup and comm speed.

8.13.5 Low power mode report rate

Low power mode report rate (0xD4)								
Bit Number	7	6	5	4	3	2	1	0
Data Access	R/W	R/W	R/W	R/W	R/W	R/W	R/W	R/W
Name	Low power mode report rate in ms							
Default	0x30 = D'48 = 48ms							
	0	0	1	1	0	0	0	0

Bit definitions:

- Bit 7-0: Low-power mode report rate in ms (**note: LPOSC timer has ± 4ms accuracy**)
 - 0-255ms: Low power mode report rate

8.13.6 Ultra-low power mode report rate

Ultra-low power mode report rate (0xD5)								
Bit Number	7	6	5	4	3	2	1	0
Data Access	R/W	R/W	R/W	R/W	R/W	R/W	R/W	R/W
Name	Ultra-low power mode report rate in 16ms increments							
Default	0x08 = D'8 * 16 = 128ms							
	0	0	0	0	1	0	0	0

Bit definitions:

- Bit 7-0: Ultra-low power mode report rate in 16ms increments
 - 0-4080ms: Ultra low power mode report rate

8.13.7 Auto mode timer

Auto mode timer (0xD6)								
Bit Number	7	6	5	4	3	2	1	0
Data Access	R/W	R/W	R/W	R/W	R/W	R/W	R/W	R/W
Name	Auto modes timer in 500ms increments							
Default	0x14 = D'20 * 500 = 10 000ms = 10sec							
	0	0	0	1	0	1	0	0

Bit definitions:

- Bit 7-0: Auto modes switching time in 500ms increments
 - 0-127.5s: Auto mode switching time



8.13.8 Global event mask

Global event mask (0xD7)								
Bit Number	7	6	5	4	3	2	1	0
Data Access	-	-	R/W	R/W	R/W	R/W	R/W	R/W
Name	-	POWER MODE EVENT	SYS EVENT	IR EVENT	ALS EVENT	HALL EVENT	SAR EVENT	PROX SENSE EVENT
Default	0x00							
	0	0	0	0	0	0	0	0

Bit definitions:

- Bit 6: Power mode event mask
 - 0: Event is allowed
 - 1: Event is masked
- Bit 5: System event mask
 - 0: Event is allowed
 - 1: Event is masked
- Bit 4: Active IR UI event mask
 - 0: Event is allowed
 - 1: Event is masked
- Bit 3: ALS UI event mask
 - 0: Event is allowed
 - 1: Event is masked
- Bit 2: Hall-effect UI event mask
 - 0: Event is allowed
 - 1: Event is masked
- Bit 1: SAR UI event mask
 - 0: Event is allowed
 - 1: Event is masked
- Bit 0: ProxSense UI event mask
 - 0: Event is allowed
 - 1: Event is masked



9 Electrical characteristics

9.1 Absolute Maximum Specifications

The following absolute maximum parameters are specified for the device:

Exceeding these maximum specifications may cause damage to the device.

Table 9.1 Absolute maximum specification

Parameter	Absolute maximum
Operating temperature	-20°C to +85°C
Supply Voltage (VDDHI – GND)	3.6V
Maximum pin voltage	VDDHI + 0.5V (may not exceed VDDHI max)
Maximum continuous current (for specific pins)	10mA
Minimum pin voltage	GND - 0.5V
Minimum power-on slope	100V/s
ESD protection	±4kV (Human body model)

9.2 Voltage regulation specifications

Table 9.2 Internal voltage regulator operating conditions

DESCRIPTION	SYMBOL	MIN	TYPICAL	MAX	UNIT
Supply voltage	VDDHI	2.0	-	3.3	V
Internal voltage regulator	VREG	1.63	1.66	1.69	V

9.3 Reset conditions

Table 9.3 Device reset specifications

DESCRIPTION	Explanation	SYMBOL	MIN	MAX	UNIT
Reset - V _{DDHI} rising level	V _{DDHI} rising level to ensure active state startup	RESET _{VDDHI} ↑	-	1.55	V
Reset - V _{DDHI} falling level	V _{DDHI} falling level to ensure reset	RESET _{VDDHI} ↓	0.70	-	
Reset - V _{REG} falling level	V _{REG} falling level for reset during LP & ULP modes	RESET _{VREG} ↓	0.65	1.41	



9.4 I²C module output logic fall time limits

Table 9.4 I²C module output logic fall time specifications

DESCRIPTION	VDDHI (V)	Temp (°C)	Pull-up resistor (Ω)	C _{LOAD} (pF)	SYMBOL	MIN	MAX	UNIT
SDA & SCL minimum fall times	1.8	-20	7000	50	TF _{min}	11.80		ns
			885	400		28.70		
		+25	7000	50		11.80		
			885	400		30.70		
		+85	7000	50		11.80		
			885	400		33.80		
	3.3	-20	7000	50		7.90		
			885	400		18.60		
		+25	7000	50		11.80		
			885	400		30.70		
		+85	7000	50		11.80		
			885	400		33.80		
SDA & SCL maximum fall times	1.8	-20	420	50	TF _{max}		42.50	ns
			420	400			65.10	
		+25	420	50			43.40	
			420	400			69.70	
		+85	420	50			45.30	
			420	400			77.30	
	3.3	-20	770	50			20.20	
			770	400			32.80	
		+25	770	50			19.90	
			885	400			34.30	
		+85	770	50			20.00	
			770	400			36.80	



9.5 I²C module slew rates

Table 9.5 I²C module fastest falling slew rates and matching rising slew rates

DESCRIPTION	VDDHI (V)	Conditions	Fall time (ns)	Rise time (ns)	SYMBOL	SR	UNIT
SDA & SCL slew rates for the minimum allowed bus capacitance	1.8	C _{BUS} = 50pF R _{PU} = 7kΩ T _A = -20°C	11.80		SR _{FALL}	61.02	V/μs
				296.55	SR _{RISE}	2.43	
	3.3	C _{BUS} = 50pF R _{PU} = 7kΩ T _A = -20°C	7.90		SR _{FALL}	167.09	
				296.55	SR _{RISE}	4.45	
SDA & SCL slew rates for the maximum allowed bus capacitance	1.8	C _{BUS} = 400pF R _{PU} = 885Ω T _A = -20°C	28.70		SR _{FALL}	25.09	
				299.94	SR _{RISE}	2.40	
	3.3	C _{BUS} = 400pF R _{PU} = 885Ω T _A = -20°C	18.60		SR _{FALL}	70.97	
				299.94	SR _{RISE}	4.40	

Table 9.6 I²C module slowest falling slew rates and matching rising slew rates

DESCRIPTION	VDDHI (V)	Conditions	Fall time (ns)	Rise time (ns)	SYMBOL	SR	UNIT
SDA & SCL slew rates for the minimum allowed bus capacitance	1.8	C _{BUS} = 50pF R _{PU} = 420Ω T _A = +85°C	45.30		SR _{FALL}	15.89	V/μs
				17.79	SR _{RISE}	40.47	
	3.3	C _{BUS} = 50pF R _{PU} = 770Ω T _A = -20°C	20.20		SR _{FALL}	65.35	
				32.62	SR _{RISE}	40.47	
SDA & SCL slew rates for the maximum allowed bus capacitance	1.8	C _{BUS} = 400pF R _{PU} = 420Ω T _A = +85°C	77.30		SR _{FALL}	9.31	
				142.34	SR _{RISE}	5.06	
	3.3	C _{BUS} = 400pF R _{PU} = 770Ω T _A = +85°C	36.80		SR _{FALL}	35.87	
				260.96	SR _{RISE}	5.06	



9.6 I²C pins (SCL & SDA) input/output logic levels

Table 9.7 I²C pins (SCL & SDA) input and output logic level boundaries

DESCRIPTION	Conditions	SYMBOL	Temperature	MIN	TYP	MAX	UNIT
Input low level voltage	400kHz I ² C clock frequency	V _{in_LOW}	-20°C	32.12			% of VDDHI
			+25°C		34.84		
			+85°C			39.39	
Input high level voltage		V _{in_HIGH}	-20°C			71.51	
			+25°C		68.18		
			+85°C	66.06			
Output low level voltage		V _{out_LOW}	-20°C – +85°C		0		
Output high level voltage		V _{out_HIGH}	-20°C – +85°C		100		

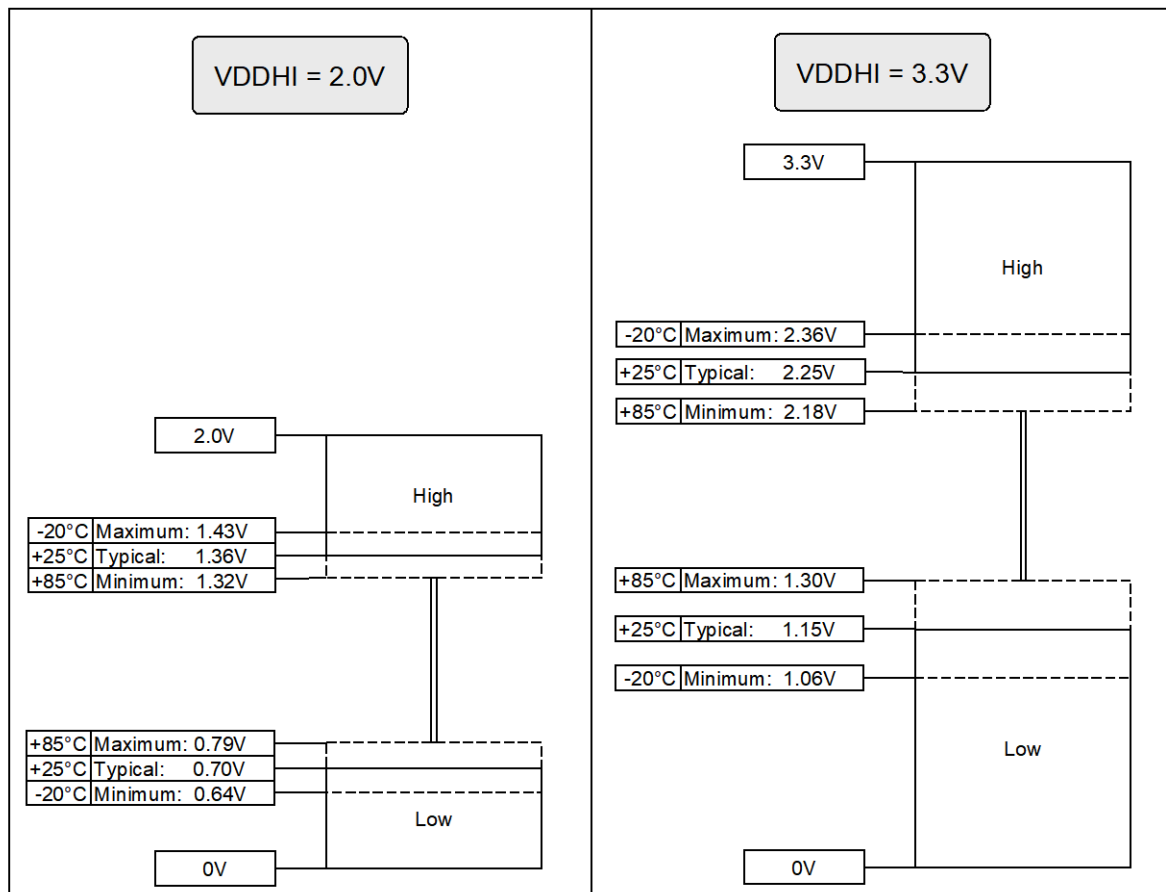

Figure 9.1 Calculated input voltage levels for GPIO pins at 400kHz I²C clock frequency for 2.0V and 3.3V VDDHI supply

9.7 General purpose digital output pins (GPIO0 & GPIO3) logic levels

DESCRIPTION	SYMBOL	Temperature	MIN	TYP	MAX	UNIT
Output low level voltage	V _{out_LOW}	-20°C – +85°C		0		% of VDDHI
Output high level voltage	V _{out_HIGH}	-20°C – +85°C		100		



9.8 Infrared LED Characteristics ⁱ

Table 9.8 Infrared LED absolute minimum and maximum specifications

DESCRIPTION	SYMBOL	CONDITIONS	MIN	TYPICAL	MAX	UNIT
Forward Voltage	V_f		-	-	1.6	V
Reverse Voltage	V_r		-	-	5	V
Continues Forward Current	I_f	$V_f = 1.6$ V	-	-	80	mA
Radiated Power	P_f	$I_f = 20$ mA	4.5	-	-	mW
Peak Wavelength	λ_p		830	-	870	nm

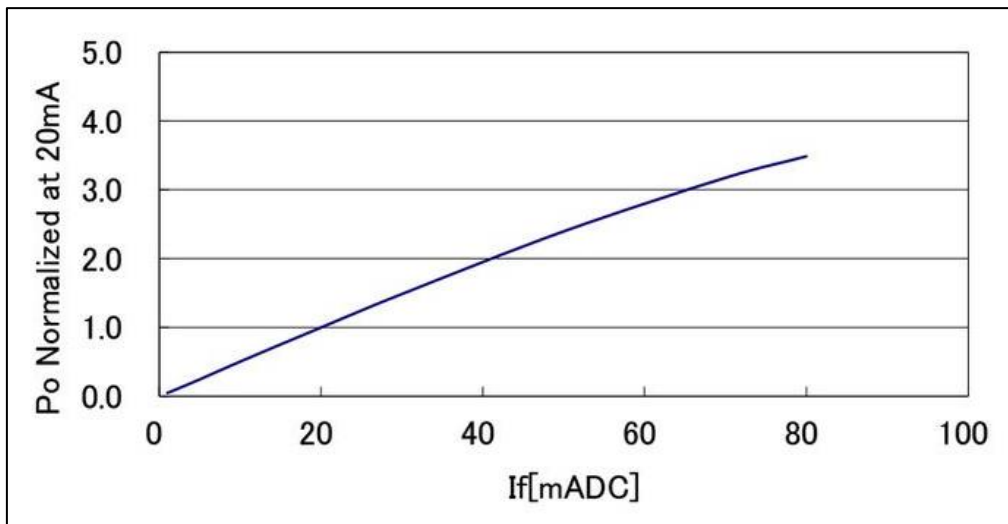

Figure 9.2 Forward LED Current vs. Normalized Radiated Power.

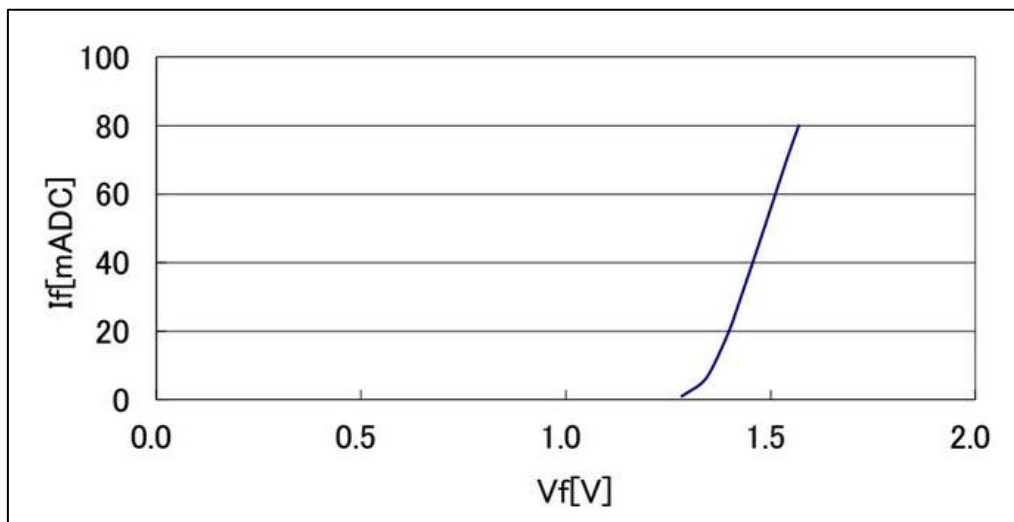

Figure 9.3 Forward LED Voltage vs. Forward LED Current.

ⁱ Details in this section are provided by DOWA ELECTRONICS MATERIALS CO., LTD



9.9 Current consumptions

Measurement conditions:

- All current measurements were done on the default memory map setup of the IQS622.
- The current measurements exclude I²C pull-up resistor currents
- The current measurements exclude the IR LED driving current into pin5: LED0. Please refer to section 9.8 for detailed IR LED characteristics.
- All measurements were taken in a period where zero active events occurred to limit I²C communications during event mode operation.

9.9.1 IC subsystems

Table 9.9 IC subsystem current consumption

Description	TYPICAL	MAX	UNIT
Core active	339	377	μA
Core sleep	0.63	1	μA

Table 9.10 IC subsystem typical timing

Power mode	Core active	Core sleep	TOTAL	UNIT
NP mode	5	5	10	ms
LP mode	5	43	48	ms
ULP mode	1.75	128	129.75	ms

9.9.2 Halt mode

Table 9.11 Halt mode current consumption

Power mode	Conditions	TYPICAL	UNIT
Halt mode	VDD = 2.0V	1.6	μA
Halt mode	VDD = 3.3V	1.9	μA

9.9.3 Capacitive sensing (2 channels active)

Table 9.12 Capacitive sensing current consumption for 2 active channels

Power mode	Conditions	Report rate	MIN	TYPICAL	MAX	UNIT
NP mode	VDD = 2.0V	10ms	59.25	59.62	60.07	μA
	VDD = 3.3V		59.59	60.05	60.52	μA
LP mode	VDD = 2.0V	48ms	16.10	16.57	16.90	μA
	VDD = 3.3V		16.62	17.25	17.78	μA
ULP mode	VDD = 2.0V	128ms	3.07	4.11	5.12	μA
	VDD = 3.3V		4.56	5.07	5.49	μA



9.9.4 Capacitive sensing with SAR (1 channel active)

Table 9.13 Capacitive sensing current consumption for 1 channel SAR

Power mode	Conditions	Report rate	MIN	TYPICAL	MAX	UNIT
NP mode	VDD = 2.0V	10ms	41.46	41.91	42.28	μA
	VDD = 3.3V		41.60	42.02	42.64	μA
LP mode	VDD = 2.0V	48ms	10.52	11.06	11.52	μA
	VDD = 3.3V		11.38	11.69	12.20	μA
ULP mode	VDD = 2.0V	128ms	2.99	4.07	5.12	μA
	VDD = 3.3V		4.61	5.08	5.42	μA

9.9.5 ALS sensing alone

Table 9.14 Ambient light sensing current consumption

Power mode	Conditions	Report rate	MIN	TYPICAL	MAX	UNIT
NP mode	VDD = 2.0V	10ms	25.92	26.26	26.48	μA
	VDD = 3.3V		26.25	26.65	27.05	μA
LP mode	VDD = 2.0V	48ms	6.91	7.19	7.49	μA
	VDD = 3.3V		7.44	7.93	8.33	μA
ULP mode	VDD = 2.0V	128ms	N/A ⁽¹⁾	N/A ⁽¹⁾	N/A ⁽¹⁾	μA
	VDD = 3.3V		N/A ⁽¹⁾	N/A ⁽¹⁾	N/A ⁽¹⁾	μA

9.9.6 Active IR sensing alone excluding LED current

Table 9.15 Active IR sensing current consumption

Power mode	Conditions	Report rate	MIN	TYPICAL	MAX	UNIT
NP mode	VDD = 2.0V	10ms	32.04	32.21	32.41	μA
	VDD = 3.3V		32.56	32.86	33.22	μA
LP mode	VDD = 2.0V	48ms	8.35	8.64	9.02	μA
	VDD = 3.3V		9.11	9.56	10.07	μA
ULP mode	VDD = 2.0V	128ms	N/A ⁽¹⁾	N/A ⁽¹⁾	N/A ⁽¹⁾	μA
	VDD = 3.3V		N/A ⁽¹⁾	N/A ⁽¹⁾	N/A ⁽¹⁾	μA

9.9.7 Active IR sensing with LED current consumption at 250 Lux

Table 9.16 Active IR sensing with LED current consumption at 250 Lux



Resistor	Conditions	Report rate	Duty Cycle	PEAK	AVG	UNIT
5.6 Ω	VDD = 2.0V	50 Hz	0.3%	54	0.16	mA
33 Ω	VDD = 3.3V	50 Hz	0.3%	55	0.16	mA
8.2 Ω	VDD = 2.0V	50 Hz	0.3%	37	0.11	mA
47 Ω	VDD = 3.3V	50 Hz	0.3%	38	0.11	mA
10 Ω	VDD = 2.0V	50 Hz	0.3%	30	0.09	mA
56 Ω	VDD = 3.3V	50 Hz	0.3%	32	0.1	mA

9.9.8 Hall-effect sensing alone

Table 9.17 Hall-effect current consumption

Power mode	Conditions	Report rate	MIN	TYPICAL	MAX	UNIT
NP mode	VDD = 2.0V	10ms	78.65	79.34	80.21	μA
	VDD = 3.3V		79.82	80.33	80.97	μA
LP mode	VDD = 2.0V	48ms	21.03	22.07	23.07	μA
	VDD = 3.3V		22.01	22.56	23.02	μA
ULP mode	VDD = 2.0V	128ms	N/A (1)	N/A (1)	N/A (1)	μA
	VDD = 3.3V		N/A (1)	N/A (1)	N/A (1)	μA

(1) It is not advised to use the IQS622 in ULP without capacitive sensing on CH0. This is due to all other sensor technologies on CH1-6 being disabled in ULP.



9.10 Start-up timing specifications

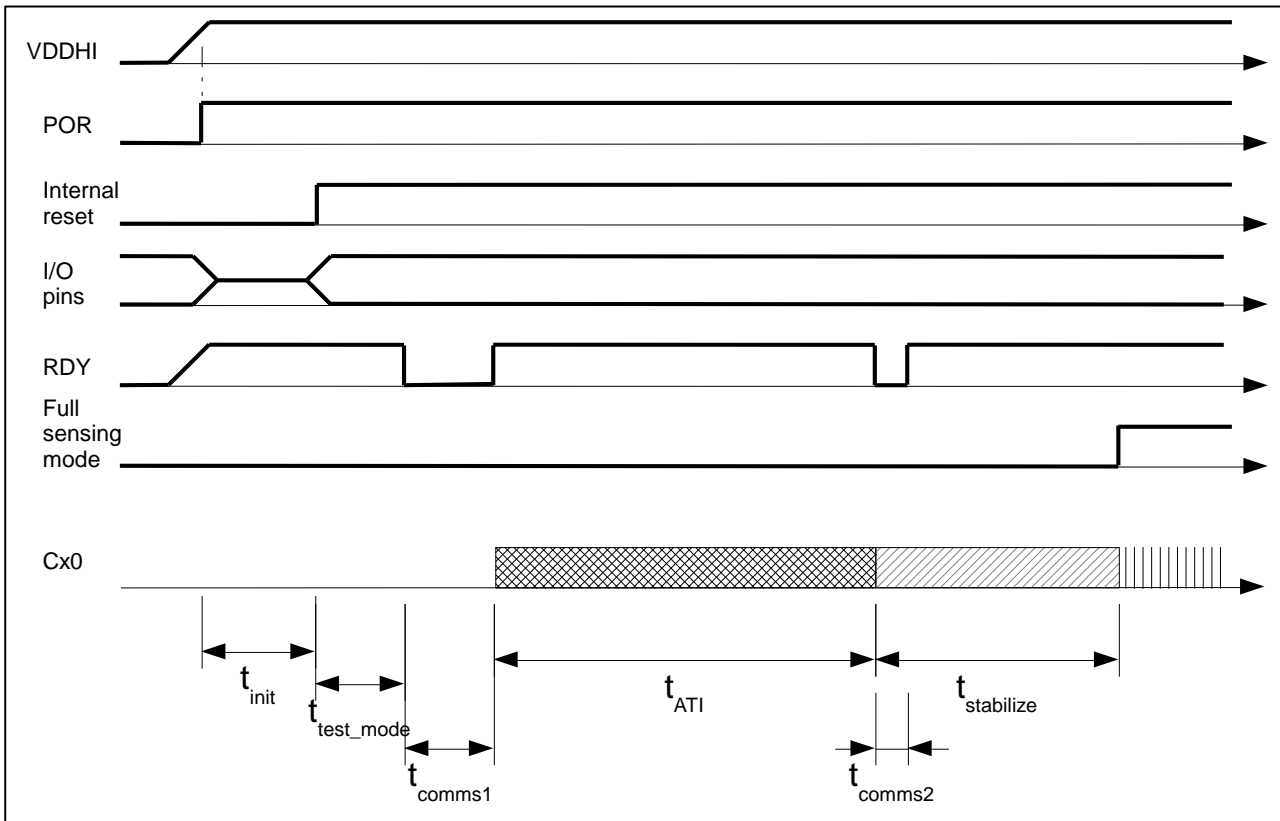

Figure 9.4 IQS622 start-up timing diagram

Table 9.18 Timing values for IQS622 start-up timing diagram

Timing	Min	Typical	Max
t_{init}		6ms	
t_{test_mode}		5ms	
t_{comms1} (16MHz)	until I ² C stop bit		2ms (time-out)
t_{comms1} (8MHz)	until I ² C stop bit		4ms (time-out)
t_{ATI} (16MHz)		110ms (default settings)	
t_{ATI} (8MHz)		220ms (default settings)	
t_{comms2} (event mode enabled – system event)	until I ² C stop bit		2ms (time-out) (x2 for 8MHz mode)
$t_{stabilize}$ (16MHz)	40ms	70ms (default settings)	
$t_{stabilize}$ (8MHz)	80ms	140ms (default settings)	
$t_{full_sensing_mode}$ (16MHz)		201ms (from POR)	
$t_{full_sensing_mode}$ (8MHz)		402ms (from POR)	

10 Package information

10.1 DMA-3.94 x 2.36 x 1.37 – 9-pin package and footprint specifications

Table 10.1 DMA 3.94 x 2.36 x 1.37 – 9-pin package dimensions (bottom)

Dimension	Min. [mm]	Nom. [mm]	Max. [mm]
A	3.84	3.94	4.04
B	2.26	2.36	2.46

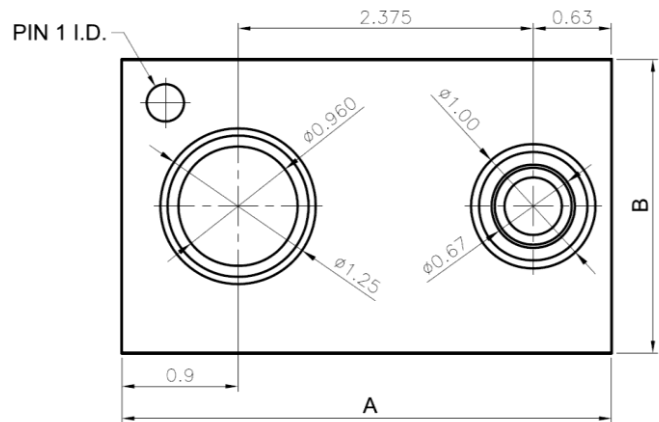

Figure 10.1 DMA 3.94 x 2.36 x 1.37 – 9-pin package dimensions (top view).

Table 10.2 DMA 3.94 x 2.36 x 1.37 – 9-pin package dimensions (side)

Dimension	Min. [mm]	Nom. [mm]	Max. [mm]
C	1.27	1.37	1.47
D	-	1.07	-
E	-	0.30	-

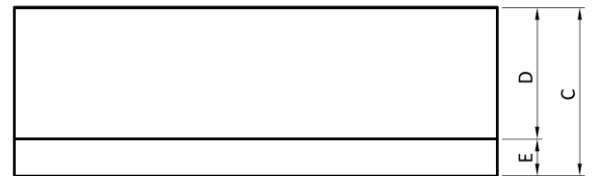

Figure 10.2 DMA 3.94 x 2.36 x 1.37 – 9-pin package dimensions (side view)

Table 10.3 DMA 3.94 x 2.36 x 1.37 – 9-pin landing pad dimensions

Dimension	Min. [mm]	Nom. [mm]	Max. [mm]
F	0.45	0.5	0.55
G	-	0.97	-
H	0.45	0.5	0.55
I	-	0.41	-
J	0.45	0.5	0.55
K	0.52	0.62	0.72
L	0.45	0.5	0.55
M	-	0.12	-

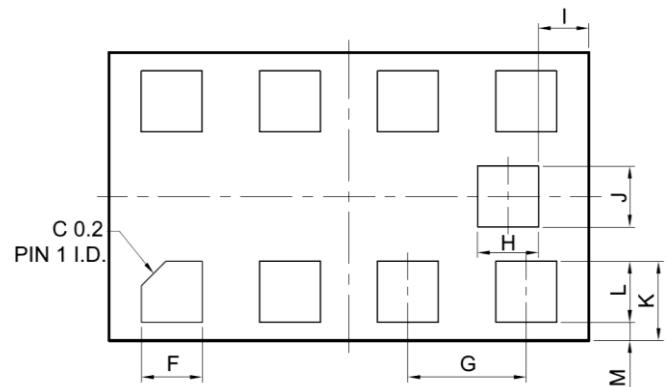
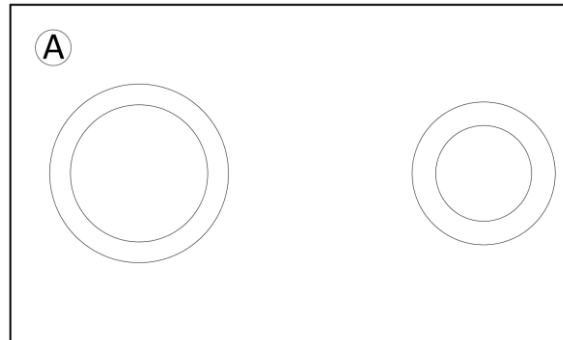

Figure 10.3 DMA 3.94 x 2.36 x 1.37 – 9-pin landing pad dimensions (bottom view)



10.2 Device mark and ordering information

10.2.1 Device mark



PIN 1 MARKING	A	=	Dot to indicate pin 1
----------------------	----------	---	-----------------------

10.2.2 Ordering Information

IQS622zppb

- z – Configuration
 - 0: 44H sub-address
 - 1: 45H sub-address
- pp – Package type
 - DM: DMA-3.94 x 2.36 x 1.37-9N
- b – Bulk packaging
 - R: Reel (3k per reel, MOQ=1 Reel)

Example:

IQS6220DMR

- 0 - configuration is default (44H sub-address)
- DM - DMA-3.94 x 2.36 x 1.37-9N package
- R - packaged in reels of 3k (must be ordered in multiples of 3k)

10.3 Bulk packaging specification

10.3.1 Tape specification

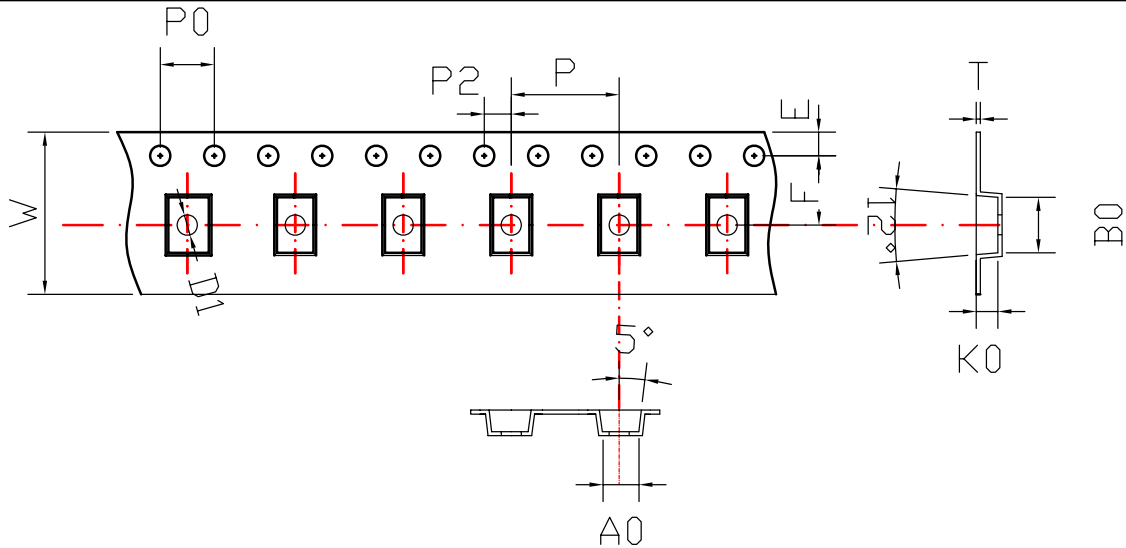

ITEM	W	A0	B0	D	D1	E	F	K0	P0	P	P2	T	10P0
DIM	12	2.80	4.40	1.50	1.50	1.75	5.50	1.70	4.0	8.0	2.0	0.30	40.0
TOLE	+0.3 -0.3	±0.10	±0.10	+0.1 -0.0	+0.1 -0.0	±0.1	±0.10	±0.10	±0.1	±0.1	±0.1	±0.05	±0.2

NOTE:

1. 10 SPROCKET HOLE PITCH CUMULATIVE TOLERANCE ± 0.2
2. CARRIER CAMBER IS 1MM IN 100MM
3. A0 AND B0 MEASURED ON A PLANCE 0.3MM ABOVE THE BOTTOM OF THE POCKET
4. K0 MEASURED FROM A PLANE ON THE INSIDE BOTTOM OF THE POCKET TO THE TOP SURFACE OF THE CARRIER
5. ALL DIMENSIONS MEET EIA-481-B REQUIREMENTS
6. PACKING LENGTH PER 13" REEL : 33 METERS
7. COMPONENT LOAD PER 13" REEL : 4000 PCS

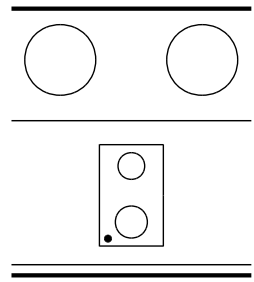

COVER TAPE SPECIFICATION

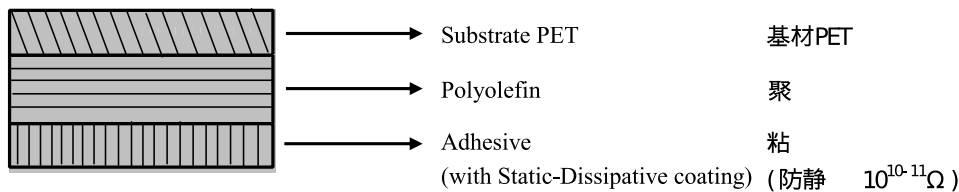

度 Width of Carrier	8	12	16	24	32	44	56	72	88
盖 度 Width of Cover Tape	5.3	9.3	13.3	21.3	25.5	37.5	49.5	65.5	81.5
包装(卷/箱) Packing (Roll/box)	38	20	15	9	7	5	4	3	2
公差(mm) Tolerance(mm):	+/-0.1								
厚度 Thickness(mm)	0.06+/-0.005								
度 Length(m)	300m+10/-0								
心 Core	3 inch (76.2mm)								



10.3.2 Reel specification

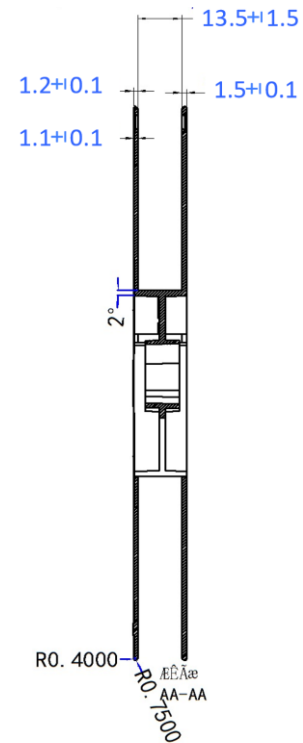
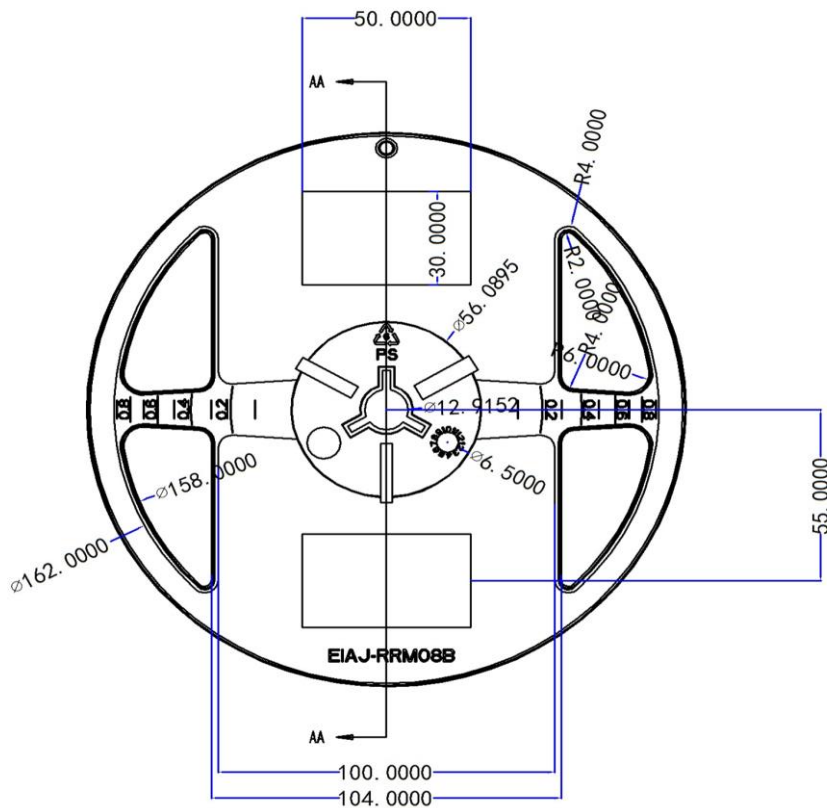
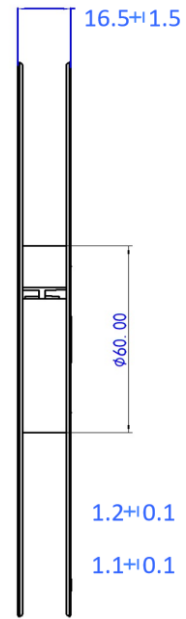
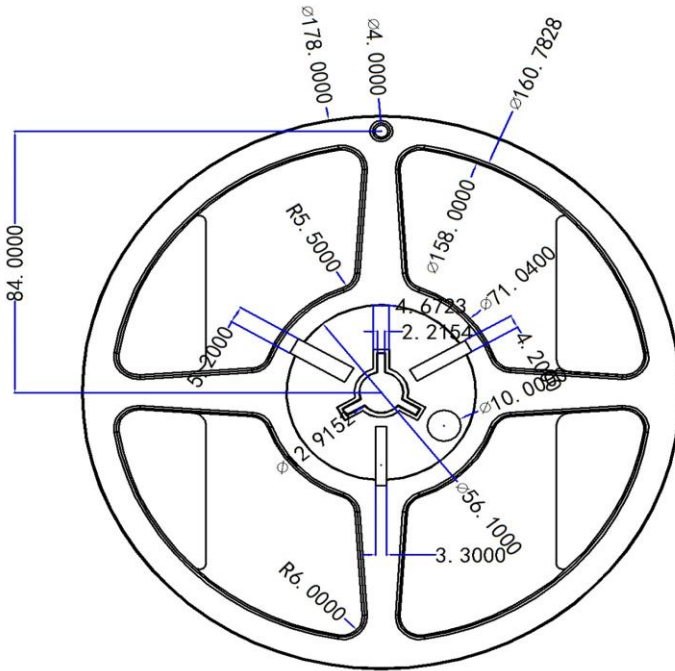



10.4 MSL Level

Moisture Sensitivity Level (MSL) relates to the packaging and handling precautions for some semiconductors. The MSL is an electronic standard for the period in which a moisture sensitive device can be exposed to ambient room conditions (approximately 30°C/60%RH see J-STD033C for more info) before reflow occur.

Package	Level (duration)
DMA-3.94 x 2.36 x 1.37-9N	MSL 4 (72 hours at ≤ 30°C / 60% RH) Reflow profile peak temperature < 180°C for < 30 seconds



11 Datasheet revisions

11.1 Revision history

- v1.00: – First release version
- v1.01: – Datasheet update:
- Memory map register added: IR Flags (address 0x15). Subsequent register addresses incremented in order to shift on position down the memory map.
 - Halt mode current consumption added.
 - General formatting updates
- v1.02: – Datasheet update:
- Default register values added (hex and binary representation) for all memory map registers.
- v1.03: – Datasheet update:
- Voltage regulation specifications added (Table 9.2).
- v1.04: – Datasheet update:
- Low power mode description corrected.
 - ProxFusion® updated to a registered trademark.
- v1.05: – Datasheet update:
- 9-pin landing pad dimensions corrected (0).
- v1.06: – Datasheet update
- Hall-effect sensing operational range confirmed and updated to 10mT – 200mT.
 - Section 1.5 ProxFusion® sensitivity added for ATI algorithm explanation.
 - Section 9.4 & 9.5 added: I²C module fall times and slew rates.
 - Section 9.6 updated and illustrated in additional Figure 9.1.
 - Appendix B. Hall ATI added.
- v1.07: – Datasheet update:
- Section 9.10 added: Start-up timing specifications.
 - Section 9.3 Reset conditions updated.
 - Appendix A. Contact information updated.

11.2 Errata



Appendix A. Contact information

	USA	Asia	South Africa
Physical Address	6507 Jester Blvd Bldg 5, suite 510G Austin TX 78750 USA	Rm1227, Glittery City Shennan Rd Futian District Shenzhen, 518033 China	109 Main Street Paarl 7646 South Africa
Postal Address	6507 Jester Blvd Bldg 5, suite 510G Austin TX 78750 USA	Rm1227, Glittery City Shennan Rd Futian District Shenzhen, 518033 China	PO Box 3534 Paarl 7620 South Africa
Tel	+1 512 538 1995	+86 755 8303 5294 ext 808	+27 21 863 0033
Fax	+1 512 672 8442		+27 21 863 1512
Email	info@azoteq.com	info@azoteq.com	info@azoteq.com

Please visit www.azoteq.com for a list of distributors and worldwide representation.

The following patents relate to the device or usage of the device: US 6,249,089; US 6,952,084; US 6,984,900; US 8,395,395; US 8,531,120; US 8,659,306; US 9,209,803; US 9,360,510; US 9,496,793; US 9,709,614; US 9,948,297; EP 2,351,220; EP 2,559,164; EP 2,748,927; EP 2,846,465; HK 1,157,080; SA 2001/2151; SA 2006/05363; SA 2014/01541; SA 2017/02224;

AirButton®, Azoteq®, Crystal Driver®, IQ Switch®, ProxSense®, ProxFusion®, LightSense™, SwipeSwitch™, and the  logo are trademarks of Azoteq.

The information in this Datasheet is believed to be accurate at the time of publication. Azoteq uses reasonable effort to maintain the information up-to-date and accurate, but does not warrant the accuracy, completeness or reliability of the information contained herein. All content and information are provided on an "as is" basis only, without any representations or warranties, express or implied, of any kind, including representations about the suitability of these products or information for any purpose. Azoteq disclaims all warranties and conditions with regard to these products and information, including but not limited to all implied warranties and conditions of merchantability, fitness for a particular purpose, title and non-infringement of any third party intellectual property rights. Azoteq assumes no liability for any damages or injury arising from any use of the information or the product or caused by, without limitation, failure of performance, error, omission, interruption, defect, delay in operation or transmission, even if Azoteq has been advised of the possibility of such damages. The applications mentioned herein are used solely for the purpose of illustration and Azoteq makes no warranty or representation that such applications will be suitable without further modification, nor recommends the use of its products for application that may present a risk to human life due to malfunction or otherwise. Azoteq products are not authorized for use as critical components in life support devices or systems. No licenses to patents are granted, implicitly, express or implied, by estoppel or otherwise, under any intellectual property rights. In the event that any of the abovementioned limitations or exclusions does not apply, it is agreed that Azoteq's total liability for all losses, damages and causes of action (in contract, tort (including without limitation, negligence) or otherwise) will not exceed the amount already paid by the customer for the products. Azoteq reserves the right to alter its products, to make corrections, deletions, modifications, enhancements, improvements and other changes to the content and information, its products, programs and services at any time or to move or discontinue any contents, products, programs or services without prior notification. For the most up-to-date information and binding Terms and Conditions please refer to www.azoteq.com.

www.azoteq.com/ip

info@azoteq.com



Appendix B. Hall ATI

Azoteq’s ProxFusion® Hall technology has ATI Functionality; which ensures stable sensor sensitivity. The ATI functionality is similar to the ATI functionality found in ProxSense® technology. The difference is that the Hall ATI requires two channels for a single plate.

Using two channels ensures that the ATI can still be used in the presence of the magnet. The two channels are the inverse of each other, this means that the one channel will sense North and the other South. The two channels being inverted allows the capability of calculating a reference value which will always be the same regardless of the presence of a magnet.

12.1.1 Hall reference value:

The equation used to calculate the reference value, per plate:

$$Ref_n = \frac{1}{2 \cdot \left(\frac{1}{P_n} + \frac{1}{P'_n} \right)}$$

12.1.2 ATI parameters:

Channel 5/6

<p>Multipliers</p> <p>Coarse : <input type="text" value="1"/> Fine : <input style="border: 1px dashed gray;" type="text" value="10"/></p>	<p>Compensation</p> <p><input type="text" value="100"/></p>	<p>ATI Target x32</p> <p><input type="text" value="16"/> <input type="text" value="512"/></p>
--	--	--

Auto ATI Mode

ATI disabled
 Partial ATI (all multipliers are fixed)
 Semi-Partial ATI (only coarse multipliers are fixed)
 Full-ATI

Auto ATI Base Value

75
 100
 150
 200

The ATI process adjusts three values (Coarse multiplier, Fine multiplier, Compensation) using two parameters per plate (ATI base and ATI target). The ATI process is used to ensure that the sensor’s sensitivity is not severely affected by external influences (Temperature, voltage supply change, etc.).

12.1.3 Coarse and Fine multipliers:

In the ATI process the compensation is set to 0 and the coarse and fine multipliers are adjusted such that the counts of the reference value (*Ref*) are roughly the same as the ATI Base value. This means that if the base value is increased, the coarse and fine multipliers should also increase and vice versa.

12.1.4 ATI-Compensation:

After the coarse and fine multipliers are adjusted, the compensation is adjusted till the reference value (*Ref*) reaches the ATI target. A higher target means more compensation and therefore more sensitivity on the sensor.

The ATI process ensures that long term temperature changes, or bulk magnetic interference (e.g. the accidental placement of another magnet too close to the setup), do not affect the sensor’s ability to detect the intended magnetic change.