

THIS DRAWING IS UNPUBLISHED. RELEASED FOR PUBLICATION 20  
 © COPYRIGHT 20 BY - ALL RIGHTS RESERVED.

REVISIONS				
P	LTR	DESCRIPTION	DATE	APVD
E		REV PER ECO 17-015222	20OCT2017	CT OC

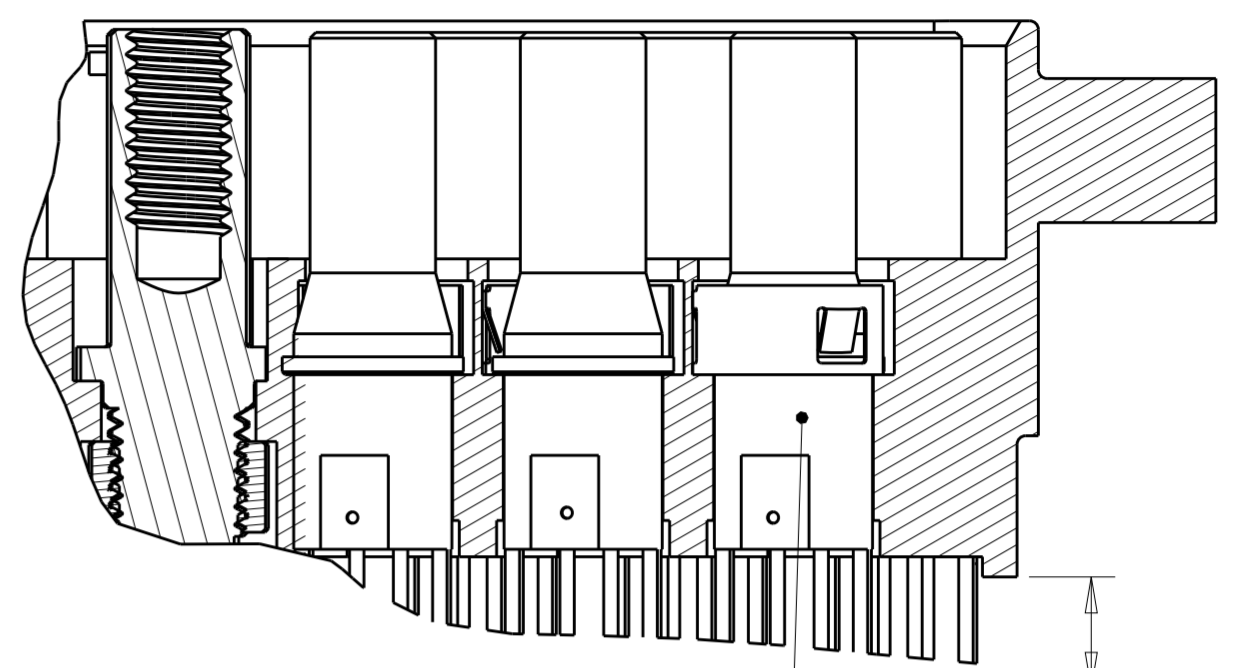

FR/FR QUADRAx PIN ASSY  
 12 REQD, NOT INCLUDED,  
 MUST BE ORDERED SEPARATELY;  
 SEE DRAWING 1445626; VARIOUS  
 TAIL LENGTHS ARE AVAILABLE

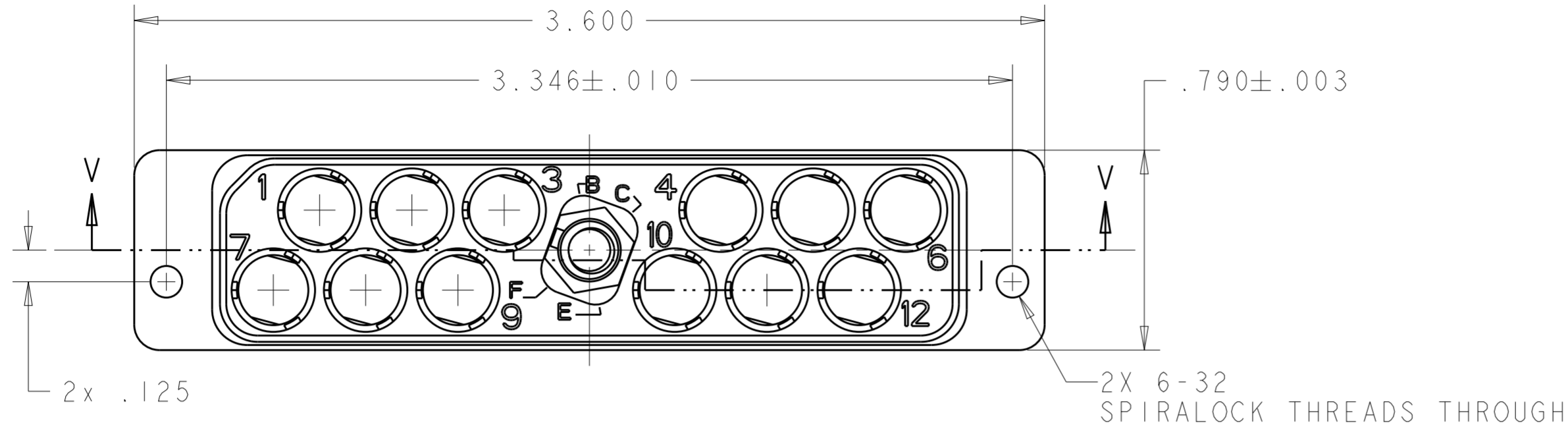
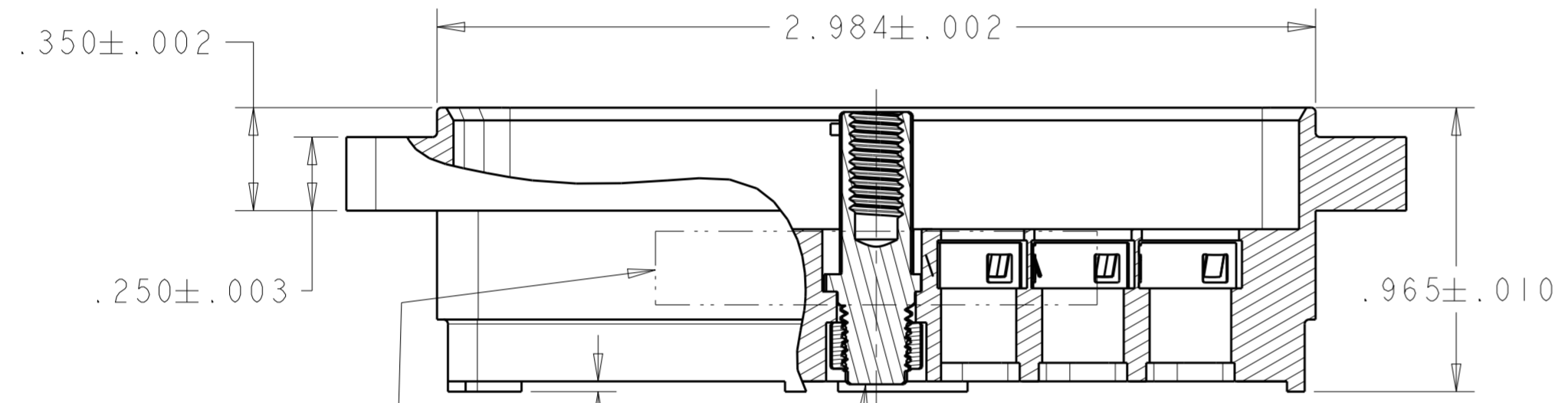

TE LOGO, TE PART NUMBER,  
 AND DATE CODE MARKED  
 APPROX AS SHOWN ON  
 NEAR OR FAR SIDE

JACK POST ASSY  
 SIMILAR TO BACC65AG  
 (NOT INCLUDED ON -1)  
 FLAT PLZLN W/ 1604798-2

SECTION V-V

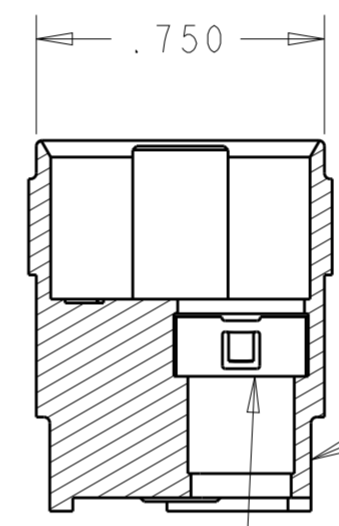

RECEPTACLE SHELL  
 MATL: ALUMINUM ALLOY  
 FINISH: ELECTROLESS  
 NICKEL

RETENTION CLIP, 12 REQD  
 MATL: STAINLESS STEEL  
 FINISH: PLATED SILVER

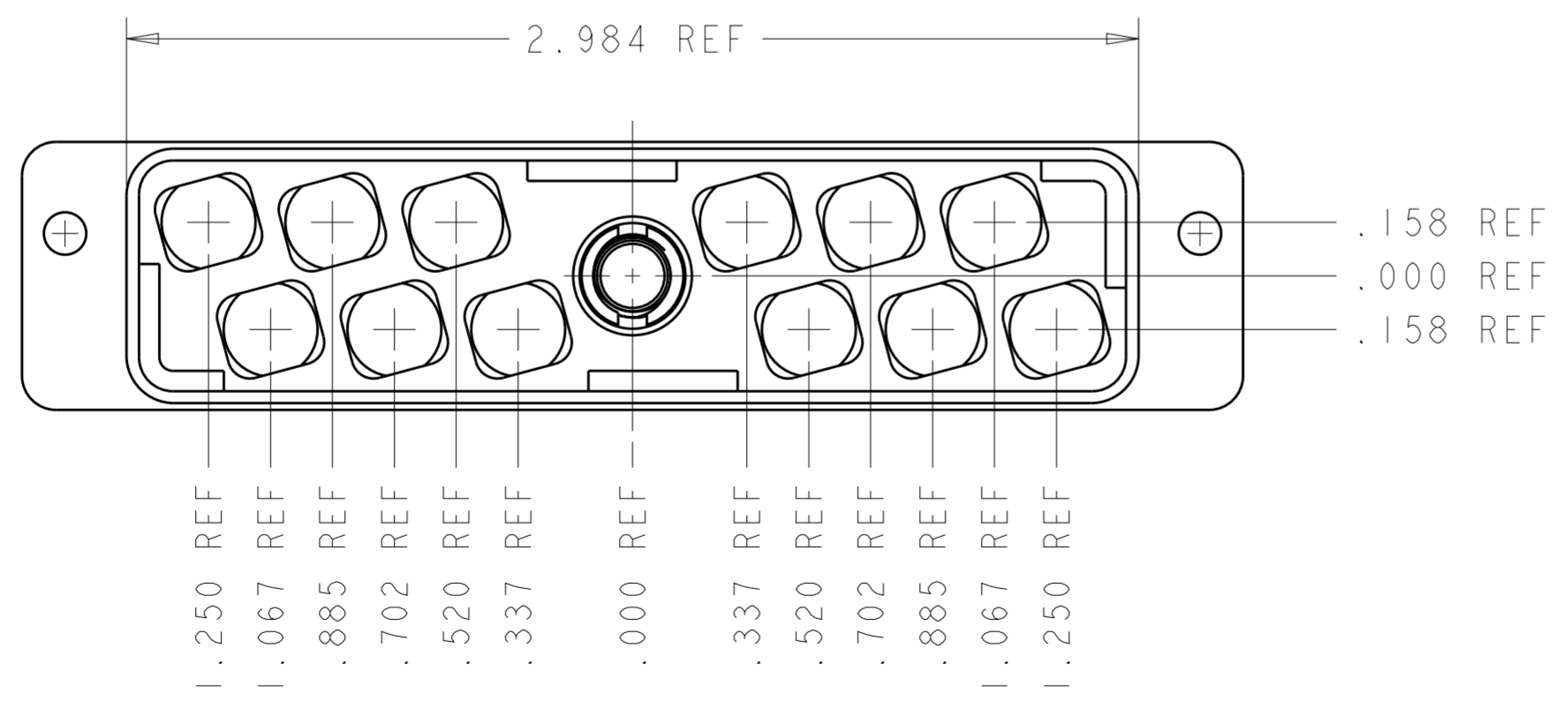

REFERENCE APPLICATION SPEC.  
 FOR RECOMMENDED BOARD LAYOUT

D	DUST COVER INCLUDED SEE SHT 2	WITH JACKPOST (FLAT POLARIZATION)	1604798-5
C	DUST COVER INCLUDED SEE SHT 2	WITH JACKPOST (FLAT POLARIZATION)	1604798-4
B	DUST COVER INCLUDED SEE SHT 2	WITH JACKPOST (FLAT POLARIZATION)	1604798-3
A	DUST COVER INCLUDED; SEE SHT 2	WITH JACKPOST (FLAT POLARIZATION)	1604798-2
-	DUST COVER NOT INCLUDED	WITHOUT JACKPOST	1604798-1
JACKPOST POLARIZATION CODE	DUST COVER P/N 1604996-1	DESCRIPTION	PART NO.

THIS DRAWING IS A CONTROLLED DOCUMENT.		DWN 25 JUNE 2004 Brent D. Yohn	 TE Connectivity
DIMENSIONS: IN		CHK 25 JUNE 2004 W. H. BERNHART	
TOLERANCES UNLESS OTHERWISE SPECIFIED:		APVD 25 JUNE 2004 W. H. BERNHART	NAME ASSEMBLY, RECEPTACLE, QUADRAx, PWB MOUNT, FR/FR, 12 POSN
0 PLC ±	1 PLC ±	PRODUCT SPEC	SIZE A2
2 PLC ±	3 PLC ±.005	APPLICATION SPEC	CAGE CODE 0779
4 ANGLES ±	FINISH -	WEIGHT -	DRAWING NO. C-1604798
MATERIAL -		CUSTOMER DRAWING	RESTRICTED TO -
		SCALE 2:1	SHEET 1 OF 2
			REV E

REVISIONS				
P	LTR	DESCRIPTION	DATE	APVD
-		SEE SHEET 1	-	-

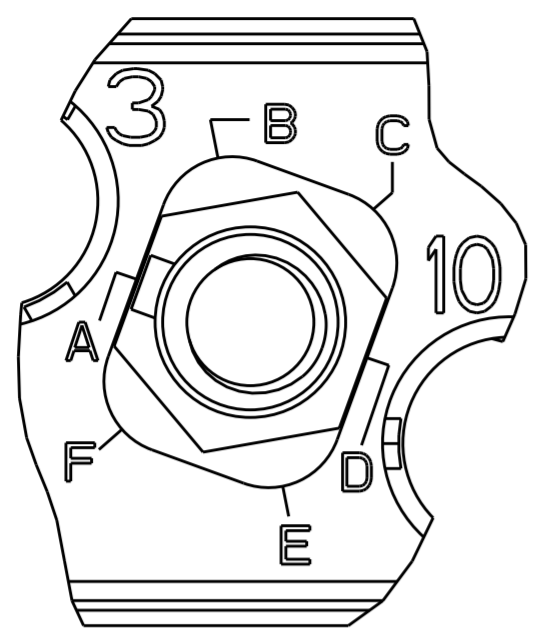

**1604798-2  
 PLZN CODE A  
 (FLAT PLZN)**

(PLZN CODES, A THRU F,  
 SHOWN FOR REF ONLY; MARKING  
 ON SHELL WILL ONLY SHOW  
 CODES B,C,E AND F)

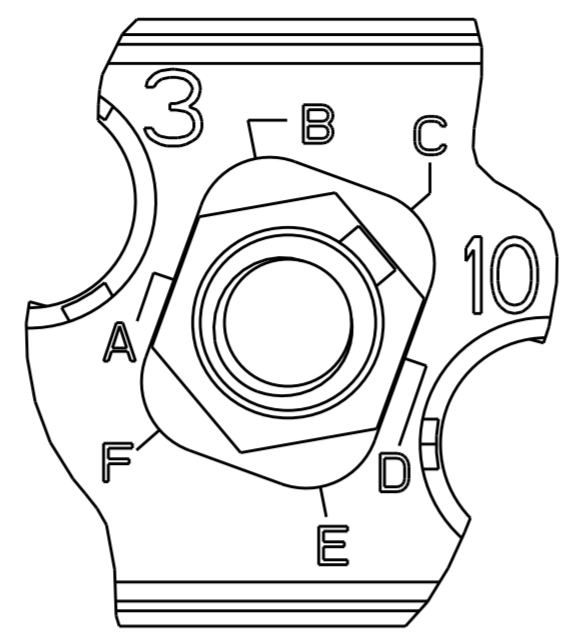

**1604798-4  
 PLZN CODE C  
 (FLAT PLZN)**

(PLZN CODES, A THRU F,  
 SHOWN FOR REF ONLY; MARKING  
 ON SHELL WILL ONLY SHOW  
 CODES B,C,E AND F)

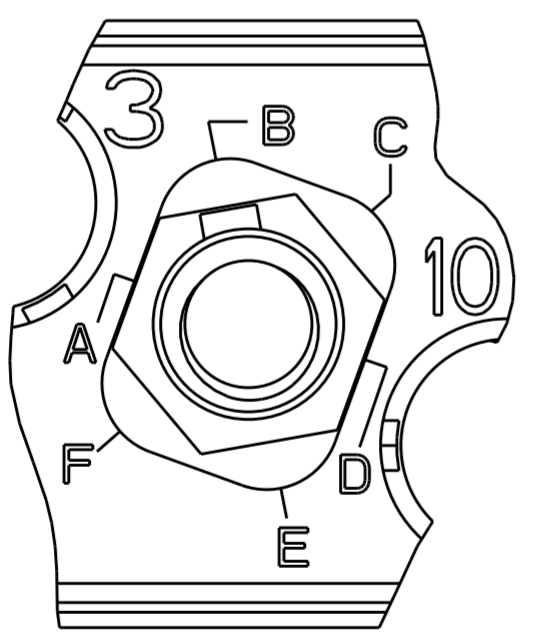

**1604798-3  
 PLZN CODE B  
 (FLAT PLZN)**

(PLZN CODES, A THRU F,  
 SHOWN FOR REF ONLY; MARKING  
 ON SHELL WILL ONLY SHOW  
 CODES B,C,E AND F)

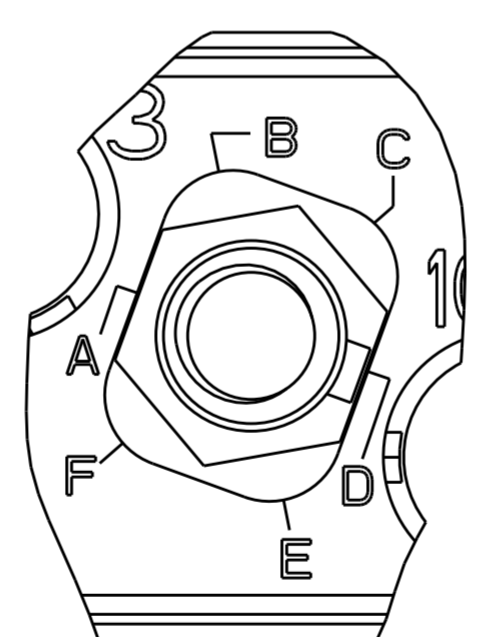

**1604798-5  
 PLZN CODE D  
 (FLAT PLZN)**

(PLZN CODES, A THRU F,  
 SHOWN FOR REF ONLY; MARKING  
 ON SHELL WILL ONLY SHOW  
 CODES B,C,E AND F)

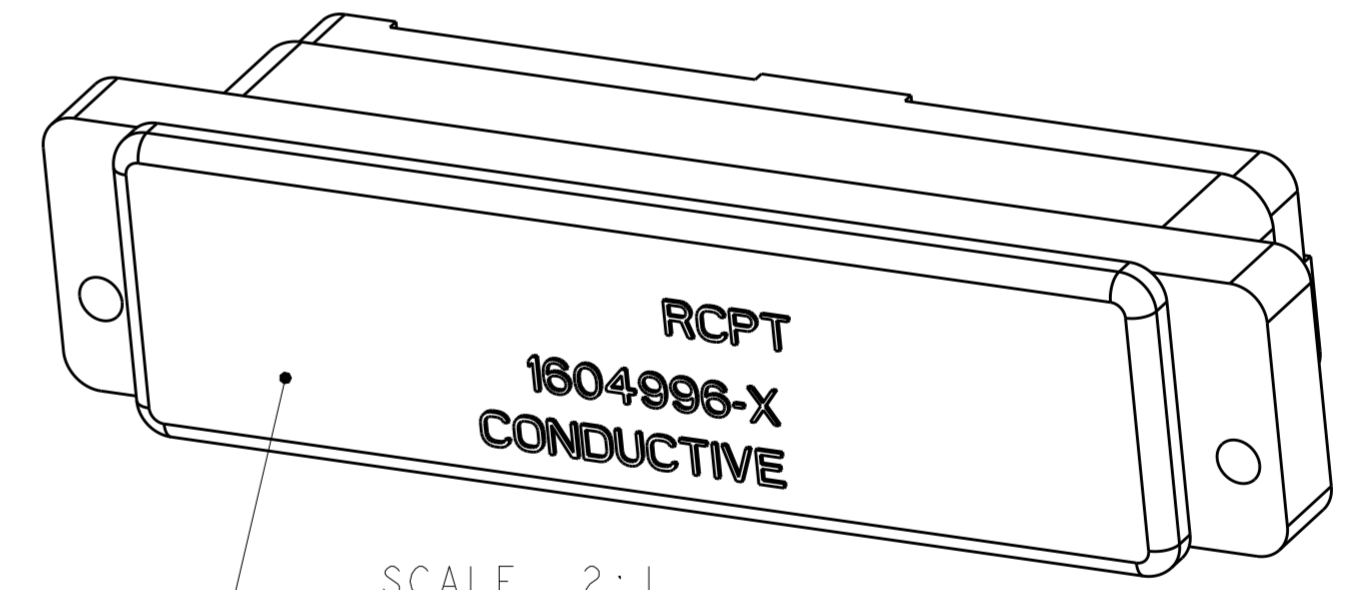

ESD DUST COVER; PART NUMBER 1604996-1  
 INCLUDED WITH ASSY PART NUMBER  
 1604798-2, -3 AND -4

**SHOWN WITH DUST COVER**

THIS DRAWING IS A CONTROLLED DOCUMENT.		DWN Brent D. Yohn 25 JUNE 2004	 TE Connectivity	
DIMENSIONS: IN		CHK W.H. BERNHART 25 JUNE 2004		
TOLERANCES UNLESS OTHERWISE SPECIFIED: 0 PLC ± 1 PLC ± 2 PLC ± 3 PLC ± 4 PLC ± ANGLES ± FINISH		APVD W.H. BERNHART 25 JUNE 2004	NAME ASSEMBLY, RECEPTACLE, QUADRAX, PWB MOUNT, FR/FR, 12 POSN	
MATERIAL -		PRODUCT SPEC -	APPLICATION SPEC -	RESTRICTED TO -
		WEIGHT -	SIZE A200779	CAGE CODE C-1604798
		CUSTOMER DRAWING	SCALE 2:1	SHEET 2 OF 2
			REV E	