

RECOMMENDED SPACING FOR PC LUGS

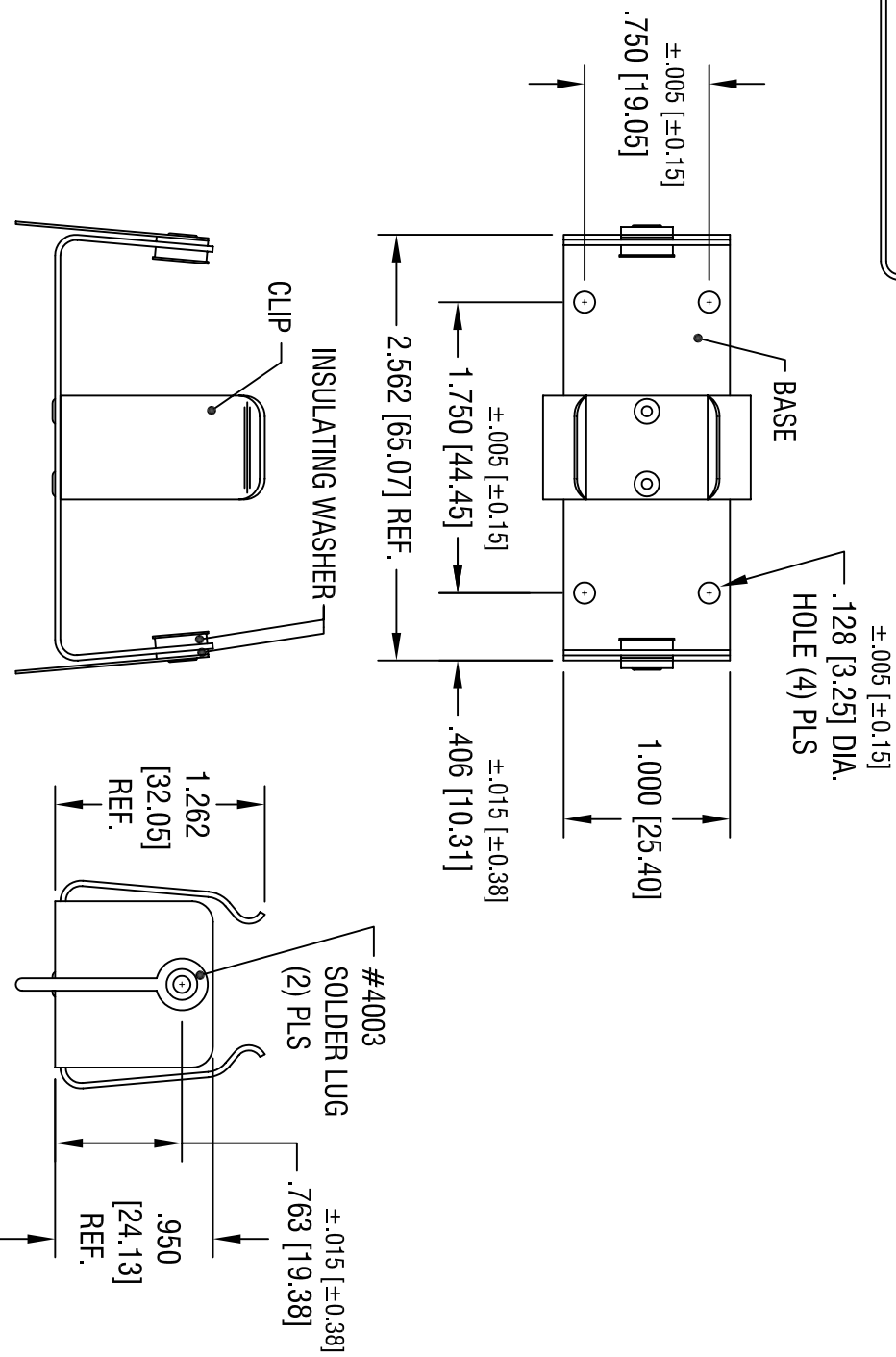
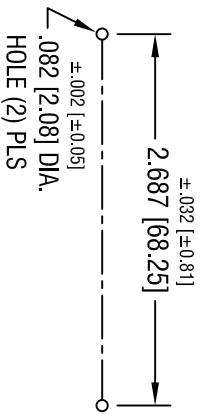

DATE	DESCRIPTION	REV.

NOTES:

- 1. BASE: MAT'L - .032 [.81] THK ALUMINUM
- CLIP: MAT'L - .032 [.81] THK ALUMINUM
- SOLDER LUG: MAT'L - BRASS
- FINISH - TIN PLATE

**KEYSTONE ELECTRONICS CORP.**

ASTORIA, N.Y. 11105-2017

PART NAME

BATTERY HOLDER, (1) 'D' CELL

MATERIAL

AS NOTED

FINISH

AS NOTED

TOLERANCES	INCH	[MM]	CODE	DWG NO.
DECIMAL	± .010	[± 0.25]	C	2226
ANGULAR	± 1°			

THIS DOCUMENT IS THE PROPERTY OF KEYSTONE ELECTRONICS CORP. AND SHALL NOT BE REPRODUCED, DISTRIBUTED OR USED AS A BASIS FOR MANUFACTURE WITHOUT PRIOR WRITTEN PERMISSION FROM KEYSTONE ELECTRONICS CORP.

DRN BY	DATE
BOONE	6.22.07

App'D	SCALE
LN	.9X