

Performance Specifications					
Characteristics	Pressure Range (psi)	MIN	TYP	MAX	UNITS
Zero Pressure Offset	ALL	-35	-20	0	mV
Sensitivity	01		3.90		mV/psi
	05		2.70		
	15		1.50		
	30		0.86		
	60		0.50		
	100		0.30		
150		0.14			
Temperature Coefficient of Span	ALL		-2150		ppm/degC
Temperature Coefficient of Offset	ALL		4		uV/V/degC
Combined Linearity and Hysteresis	ALL		0.2		%FS
Long Term Stability	ALL		0.1		mV
Response Time (10% to 90%)	ALL		100		us
Input Resistance	ALL		4.1		kohms
Temperature Coefficient of Resistance	ALL		750		ppm/degC
Output Impedance	ALL		4.1		kohms
Repeatability	ALL		0.5		%FSS
Overpressure	01, 05		20		psi
	15		30		
	30		60		
	60		90		
	100		150		
150		200			

Specifications	
Characteristics	Maximum Ratings
Supply voltage	12 Vdc
Operating Temperature	-40C to +125C
Storage Temperature	-55C to +125C
Lead Temperature (Soldering 2s to 4s)	250C

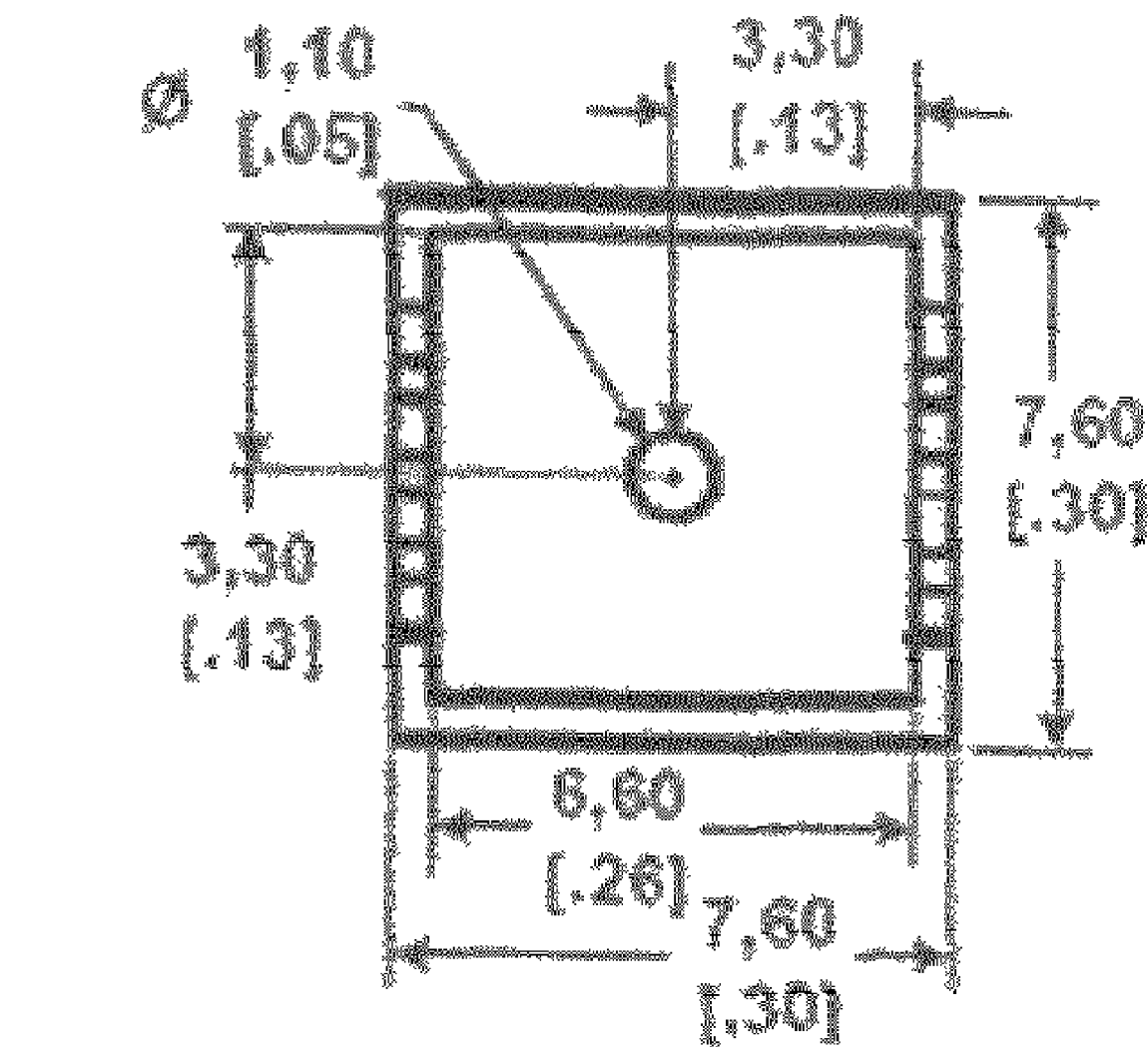

PORTED "P" SMT

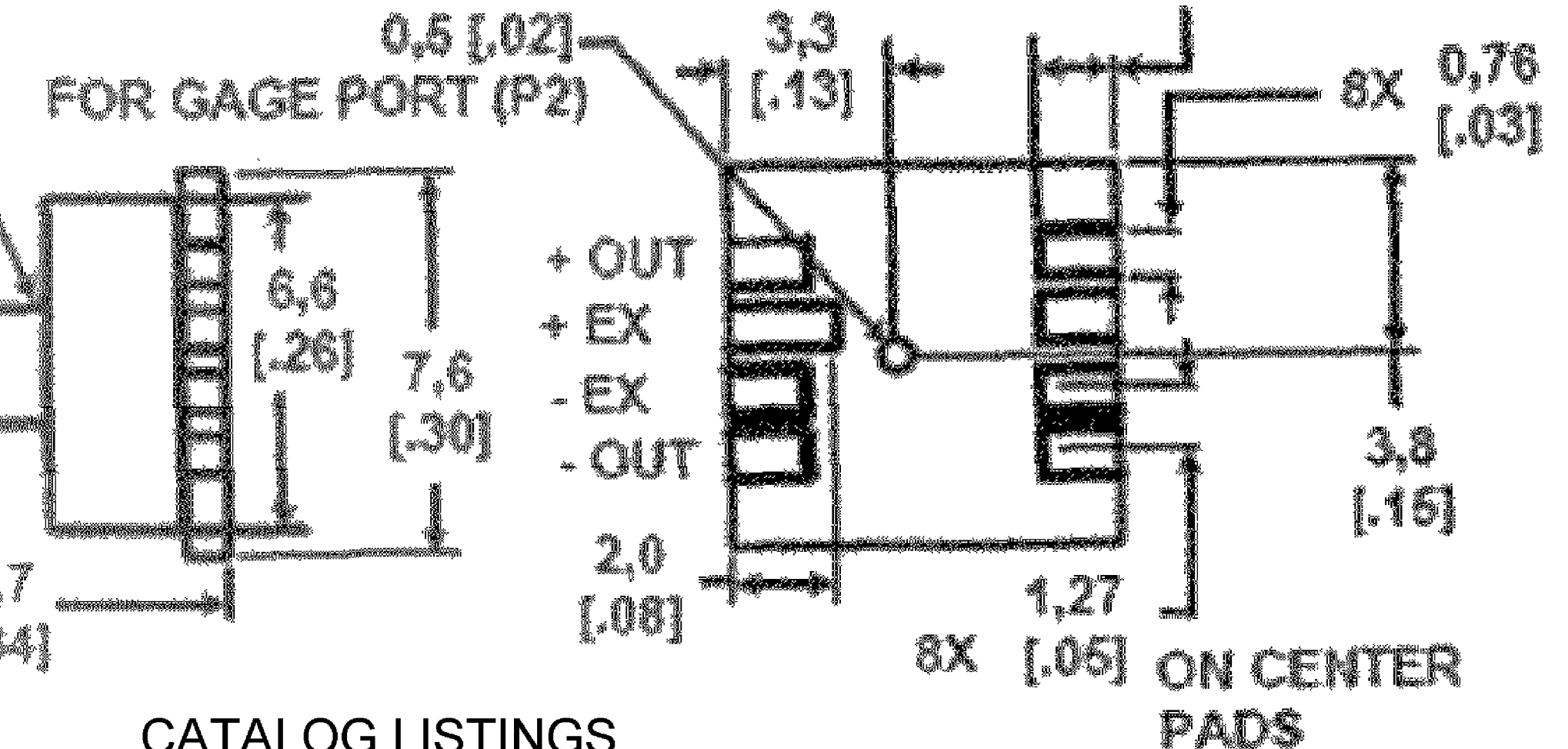
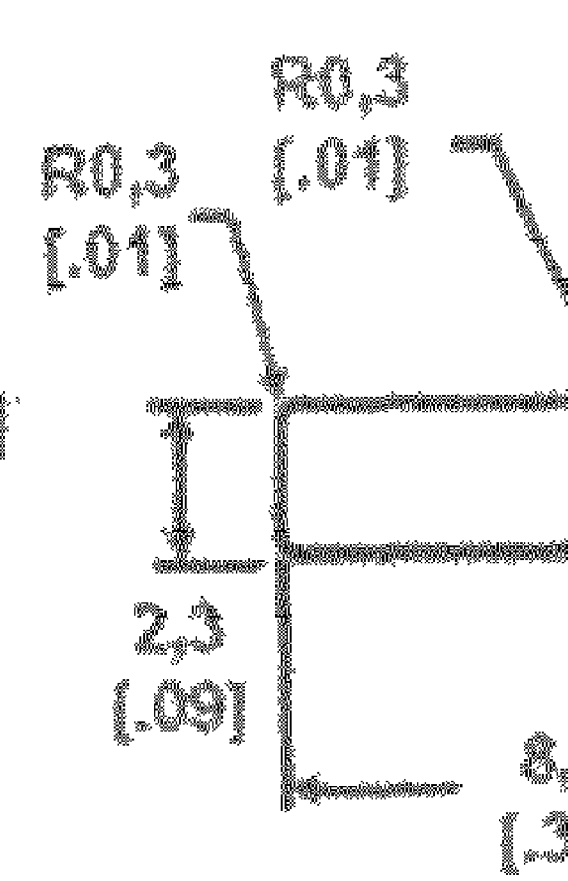
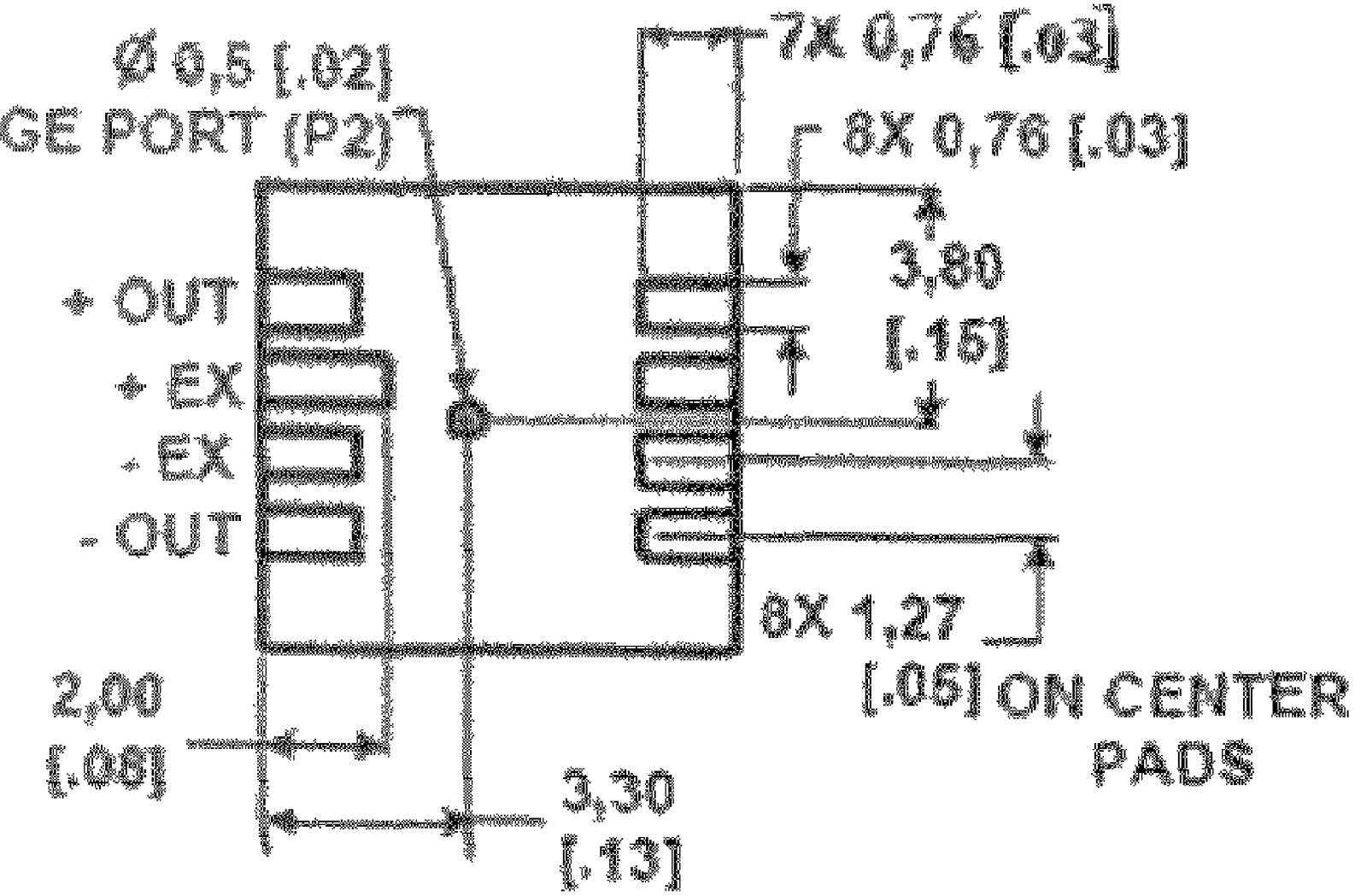
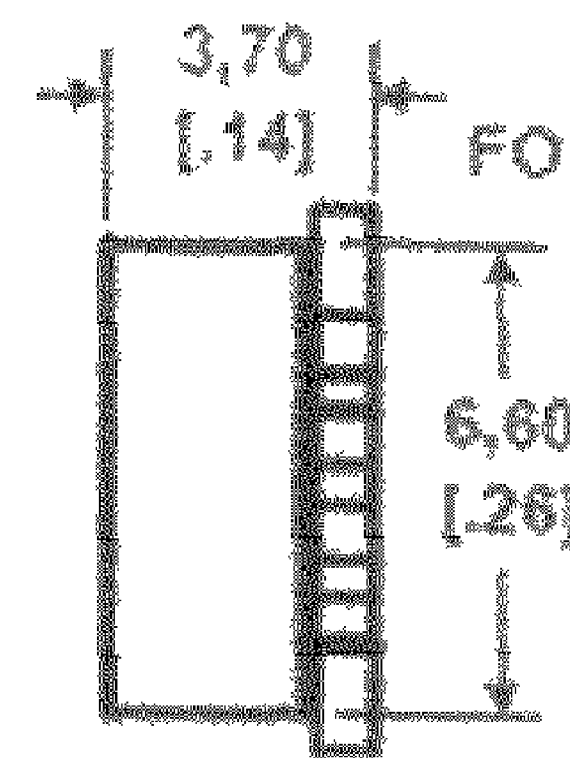
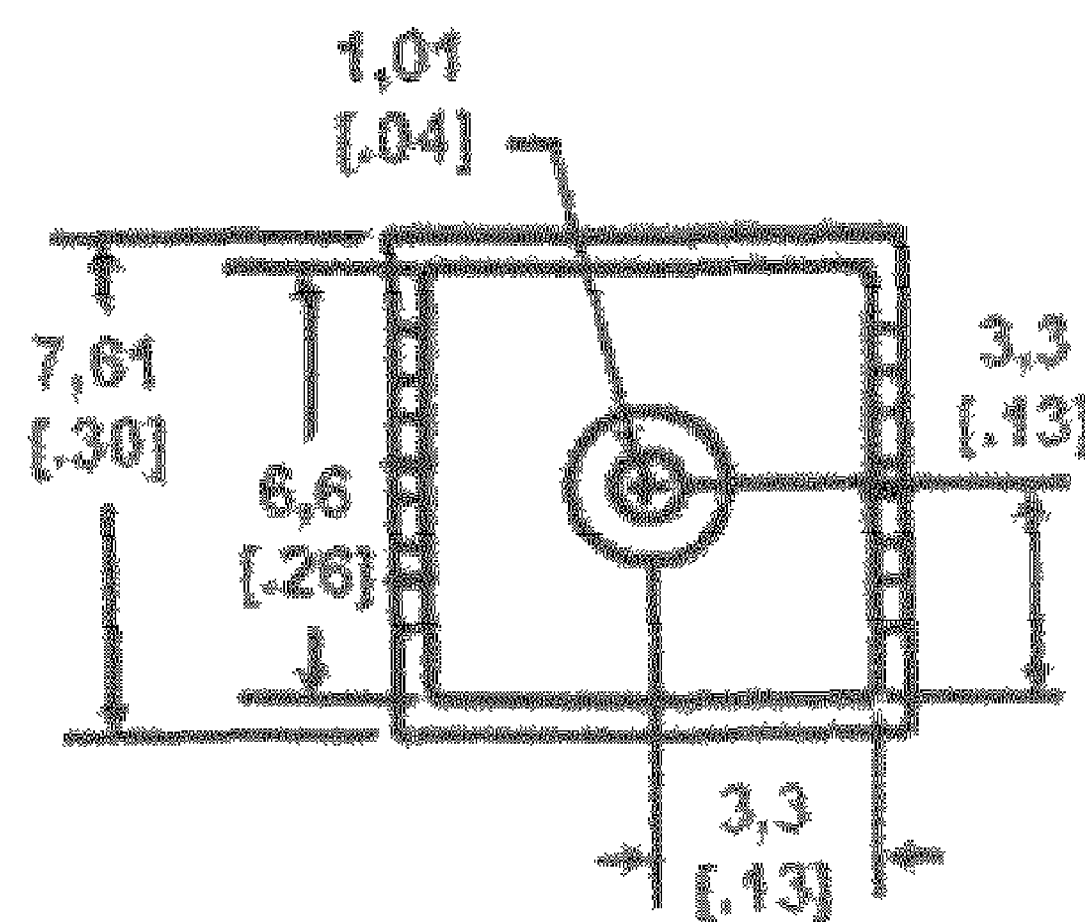

CATALOG LISTINGS

- | | |
|-------------|--------------|
| SX01GSMT | SX100ASMT |
| SX01GSMTTP | SX100GSMT |
| SXP01GSMTTP | SX100GSMTTP |
| | SXP100ASMT |
| | SXP100GSMTTP |
| SXP05GSMTTP | SXP100GSMTTP |
| SX15ASMT | SX150ASMT |
| SX15ASMTTP | SX150GSMT |
| SX15GSMT | SXP150ASMT |
| SXP15ASMTTP | SXP150ASMTTP |
| SXP15GSMTTP | SXP150GSMT |
| SX30ASMT | |
| SX30GSMT | |
| SXP30ASMTTP | |

EQUIVALENT CIRCUITS

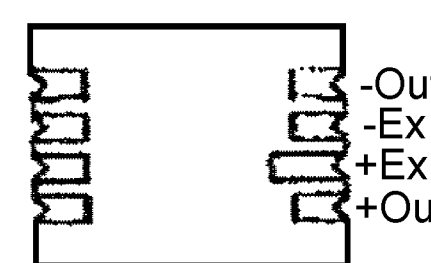
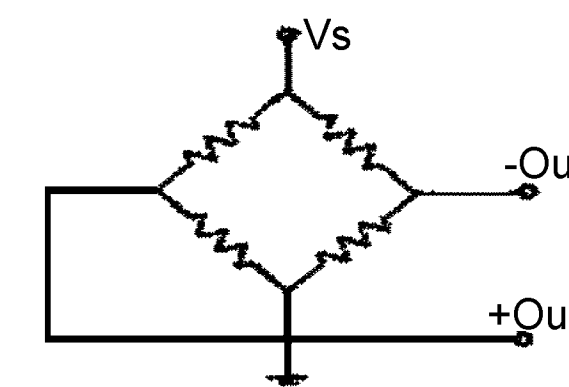

- NOTES:
- 1) REFERENCE CONDITIONS: SUPPLY VOLTAGE, VS= 5.0 Vdc, TEMP = 0degC TO 70degC
 - 2) IF MAXIMUM PRESSURE IS EXCEEDED, EVEN MOMENTARILY, THE PACKAGE MAY LEAK OR BURST, OR THE PRESSURE SENSING DIE MAY FRACTURE.
 - 3) SENSITIVITY IS THE RATIO OF THE OUTPUT SIGNAL VOLTAGE CHANGE TO INPUT PRESSURE CHANGE. THE SENSITIVITY IS CHARACTERIZED BY DESIGN AND PERIODIC PRODUCTION TESTING. THIS PARAMETER IS NOT 100% TESTED IN PRODUCTION.
 - 4) TEMPERATURE COEFFICIENT IS DEFINED AS BEST FIT STRAIGHT LINE FIT FOR OPERATION BETWEEN 0degC TO 70degC.
 - 5) TEMPERATURE COEFFICIENT IS NOT 100% TESTED. IT IS DEFINED BY PROCESS DESIGN.
 - 6) SLOPE OF BEST FIT STRAIGHT LINE FIT FOR OPERATION BETWEEN 0degC TO 70degC.
 - 7) LONG TERM STABILITY OVER A ONE YEAR PERIOD.
 - 8) RESPONSE TIME FOR 0 psi TO FULL SCALE SPAN PRESSURE STEP CHANGE.

DESIGN UNITS: MM	DRAWN	SK	19OCT06	Honeywell	
TOLERANCES UNLESS NOTED:	CHECK	CMH	19OCT06		
NO PLACE X ± 1,000	THIS DRAWING COVERS A PROPRIETARY ITEM AND IS THE PROPERTY OF HONEYWELL. THIS DRAWING IS NOT TO BE COPIED OR USED WITHOUT THE PERMISSION OF HONEYWELL.			TITLE	
ONE PLACE .X ± 0,4				SCALE	NONE
TWO PLACE .XX ± 0,15				SIZE	D I
THREE PLACE .XXX ± 0,005				TYPE	I
FOUR PLACE .XXXX ± 0,0050				DRAWING NAME	SX SMT SERIES CHART 1
ANGLES X ± 3	INTERPRET PER ASME Y14.5M-1994 OTHER HONEYWELL ENGINEERING STANDARDS MAY APPLY	REVISION	B		
THIRD ANGLE PROJECTION	RASTER	SHEET	1 OF 1		