

THIS DRAWING IS UNPUBLISHED. RELEASED FOR PUBLICATION  
 © COPYRIGHT BY TYCO ELECTRONICS CORPORATION. ALL RIGHTS RESERVED.

LOC	DIST	REVISIONS			
P	LTR	DESCRIPTION	DATE	DWN	APVD
FT	0	F1	REVISED PER ECO-06-13762	6/19/06	SS SRY

- 1 STAINLESS STEEL.
- 2 BRASS.
- 3 1.27um [.000050] MIN TIN-LEAD OVER 1.27um [.000050] MIN NICKEL.
- 4 WIRE RANGE: 20-24 AWG. INSULATION RANGE: 1.52-3.05 [.060-.120] DIA.
- 5 0.38um [.000015] MIN GOLD IN LOCALIZED GOLD PLATE AREA, OVER 1.27um [.000050] MIN NICKEL.
- 6 0.76um [.000030] MIN GOLD IN LOCALIZED GOLD PLATE AREA, OVER 1.27um [.000050] MIN NICKEL.
- 7 1.27um [.000050] MIN TIN OVER 1.27um [.000050] MIN NICKEL.

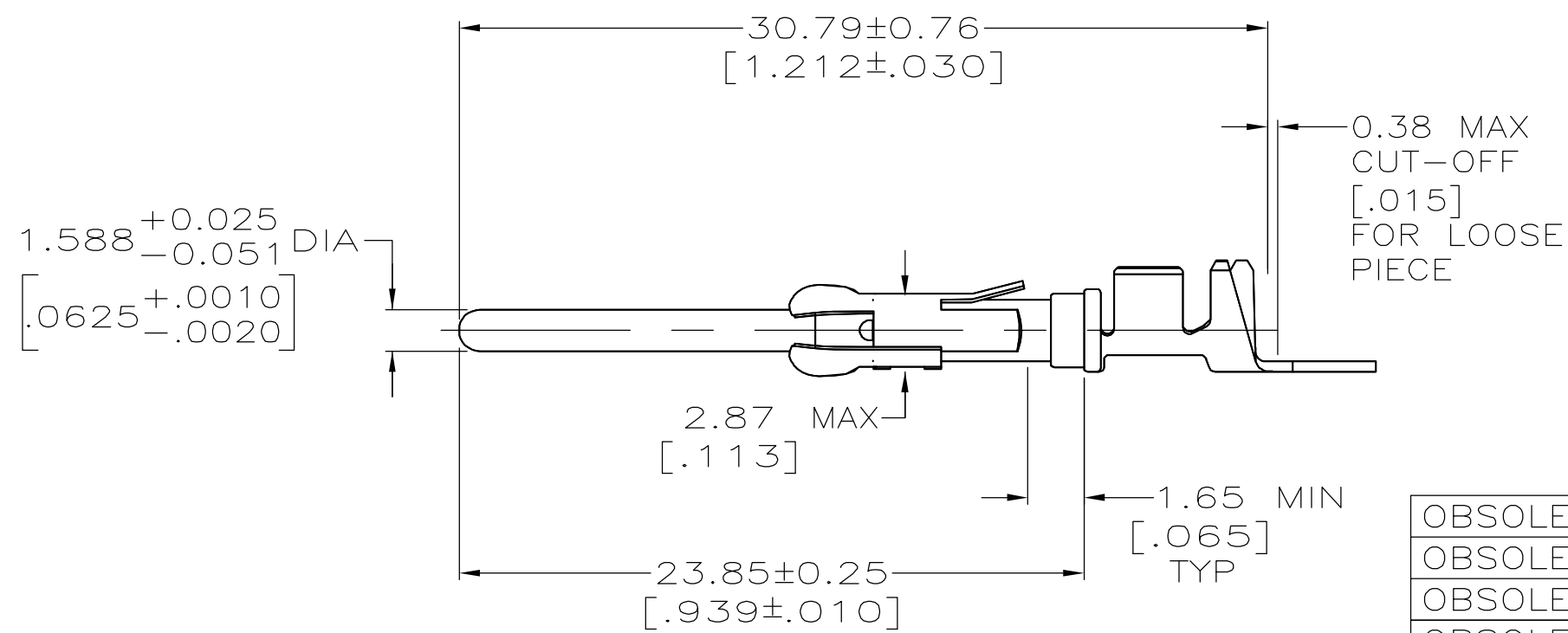
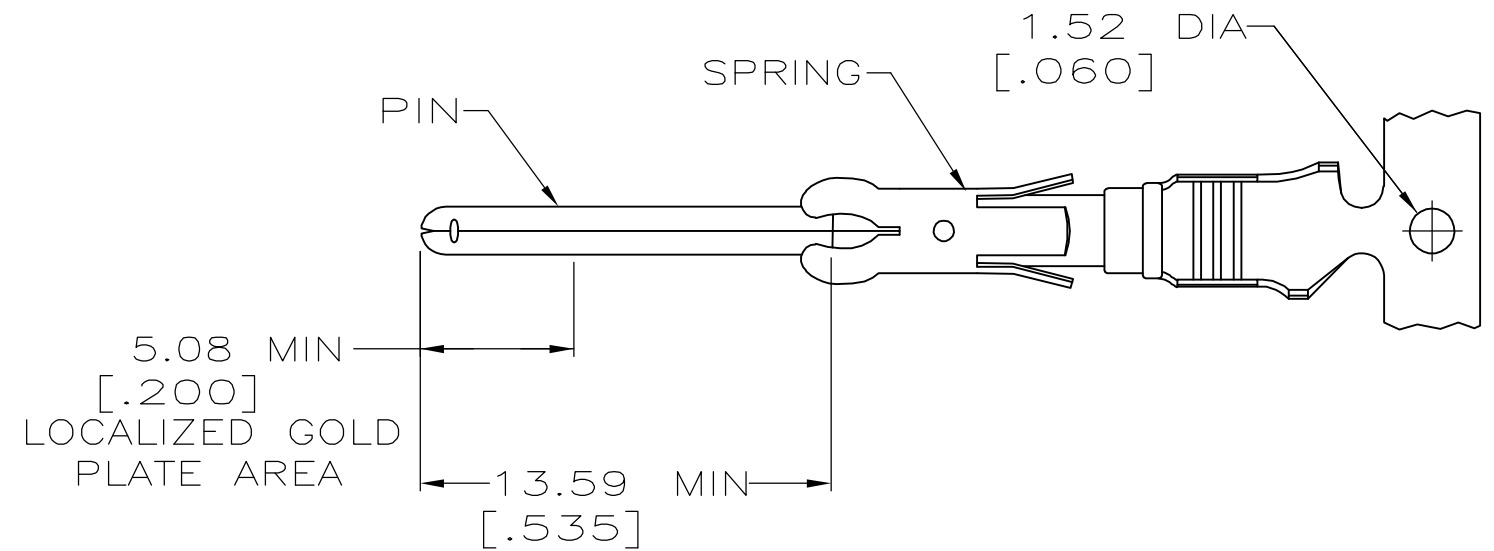

	DESCRIPTION	PIN FINISH	PART NO.
	STRIP	7	213605-7
OBSOLETE	LOOSE PIECE	6	213605-6
OBSOLETE	STRIP	6	213605-5
OBSOLETE	LOOSE PIECE	5	213605-4
OBSOLETE	STRIP	5	213605-3
OBSOLETE	LOOSE PIECE	3	213605-2
	STRIP	3	213605-1

THIS DRAWING IS A CONTROLLED DOCUMENT.		DWN L.SIPE 05/07/90	Tyco Electronics Corporation Harrisburg, PA 17105-3608			
DIMENSIONS: mm [INCHES]		CHK R.STONE 5-17-90				
TOLERANCES UNLESS OTHERWISE SPECIFIED:		APVD -	NAME			
0 PLC ± - 1 PLC ± - 2 PLC ± 0.13 [.005] 3 PLC ± - 4 PLC ± - ANGLES ± -		PRODUCT SPEC -	PIN ASSEMBLY, 5015 SERIES, 20-24 AWG, SPECIAL TYPE III+			
MATERIAL		APPLICATION SPEC -	SIZE	CAGE CODE	DRAWING NO	RESTRICTED TO
SPRING: 1 PIN: 2		WEIGHT -	A3	00779	C-213605	-
FINISH		CUSTOMER DRAWING		SCALE	SHEET	REV
PIN: SEE TABLE				4:1	1 OF 1	F1