

## Ultralow Power Boost Converters with Output Disconnect

### DESCRIPTION

Demonstration circuits 1387A-A, and -B are Ultralow Power Boost Converters with Output Disconnect featuring the LT8410 and LT8410-1. Both versions convert a 3V-10V source to 16V. The -A version supplies 1.6mA at 3V<sub>in</sub> and the -B supplies 0.5mA.

Both versions feature a low noise control scheme, integrated schottky diode and output disconnect function, ultra-low quiescent current, built in soft-start and over-voltage protection. The LT8410 datasheet gives a complete description of the parts, their operation and application information. The datasheet must be read in conjunction with this quick start guide for working on or modifying the demo circuit 1387.

These circuits are intended for space-conscious applications such as Sensor Power, RF Mems and General Purpose Bias Supplies.

**Design files for this circuit board are available. Call the LTC factory.**

 , LTC, LTM, LT are registered trademarks of Linear Technology Corporation.

### PERFORMANCE SUMMARY FOR DC1387A-A/LT8410 Specifications are at TA = 25°C

SYMBOL	PARAMETER	CONDITIONS	MIN	TYP	MAX	UNITS
V <sub>IN</sub>	Input Supply Range		3		10	V
V <sub>OUT</sub>	Output Voltage Range	V <sub>IN</sub> = 3V, I <sub>LOAD</sub> = 1.6mA	15.54	16	16.48	V
V <sub>OUT</sub>	Output Voltage Range	V <sub>IN</sub> = 10V, I <sub>LOAD</sub> = 10mA	15.54	16	16.48	V
RIPPLE		V <sub>IN</sub> = 10V, I <sub>LOAD</sub> = 10mA		20		mV
EFFICIENCY		V <sub>IN</sub> = 3V, I <sub>LOAD</sub> = 1.6mA		73		%
EFFICIENCY		V <sub>IN</sub> = 10V, I <sub>LOAD</sub> = 10mA		83		%

### PERFORMANCE SUMMARY FOR DC1387A-B/LT8410-1 Specifications are at TA = 25°C

SYMBOL	PARAMETER	CONDITIONS	MIN	TYP	MAX	UNITS
V <sub>IN</sub>	Input Supply Range		3		10	V
V <sub>OUT</sub>	Output Voltage Range	V <sub>IN</sub> = 3V, I <sub>LOAD</sub> = 0.5mA	15.52	16	16.48	V
V <sub>OUT</sub>	Output Voltage Range	V <sub>IN</sub> = 10V, I <sub>LOAD</sub> = 3mA	15.52	16	16.48	V
RIPPLE		V <sub>IN</sub> = 10V, I <sub>LOAD</sub> = 3mA		10		mV
EFFICIENCY		V <sub>IN</sub> = 3V, I <sub>LOAD</sub> = 0.5mA		69		%
EFFICIENCY		V <sub>IN</sub> = 10V, I <sub>LOAD</sub> = 3mA		83		%

## QUICK START PROCEDURE

Demonstration circuit 1387 is easy to set up to evaluate the performance of the LT8410 and LT8410-1. Refer to Figure 1 for proper measurement equipment setup and follow the procedure below:

**NOTE.** When measuring the input or output voltage ripple, care must be taken to avoid a long ground lead on the oscilloscope probe. Measure the input or output voltage ripple by touching the probe tip directly across the Vin or Vout and GND terminals. See Figure 2 for proper scope probe technique.

1. Place jumpers in the following positions:

JP1 Run

2. With power off, connect the input power supply to Vin and GND.

3. Turn on the power at the input.

Check for the proper output voltages.  $V_{out} = 15.52V$  to  $16.48V$ .

**NOTE.** If there is no output, temporarily disconnect the load to make sure that the load is not set too high.

4. Once the proper output voltage is established, adjust the load within the operating range and observe the output voltage regulation, ripple voltage, efficiency and other parameters.

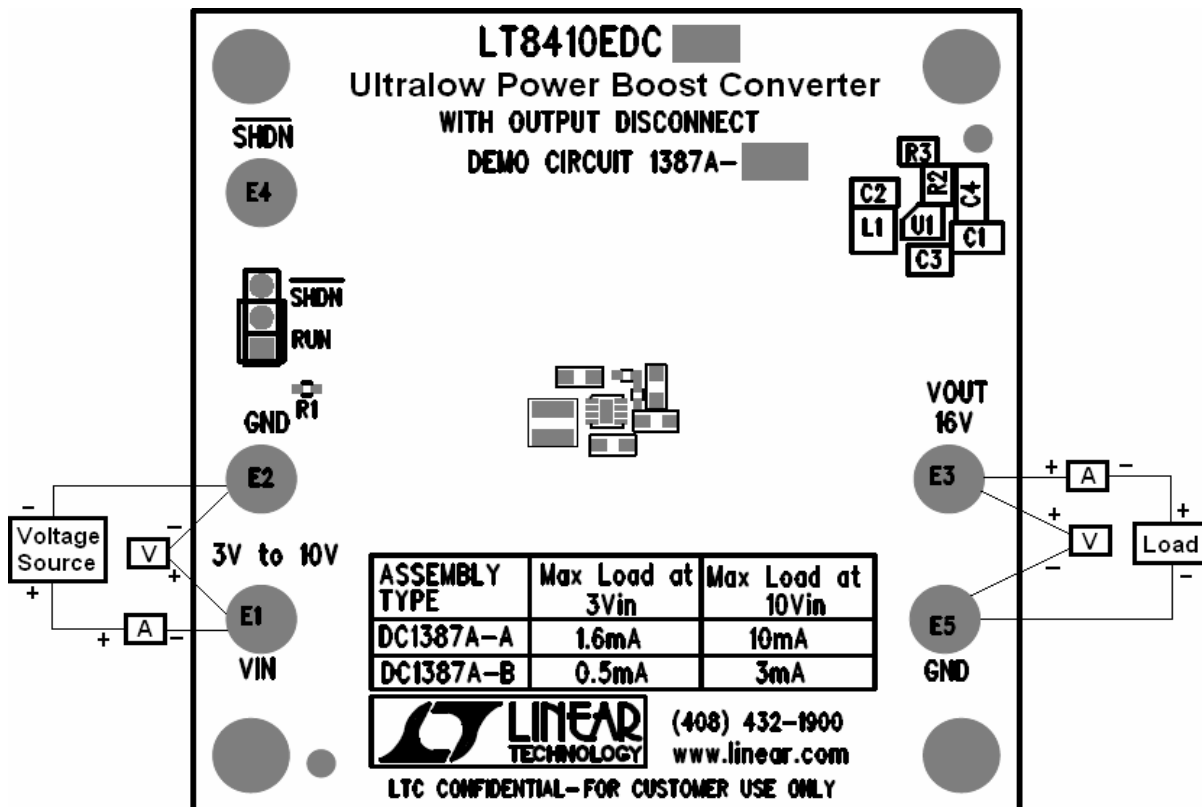

Figure 1. Proper Measurement Equipment Setup

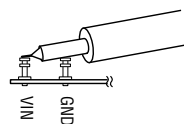
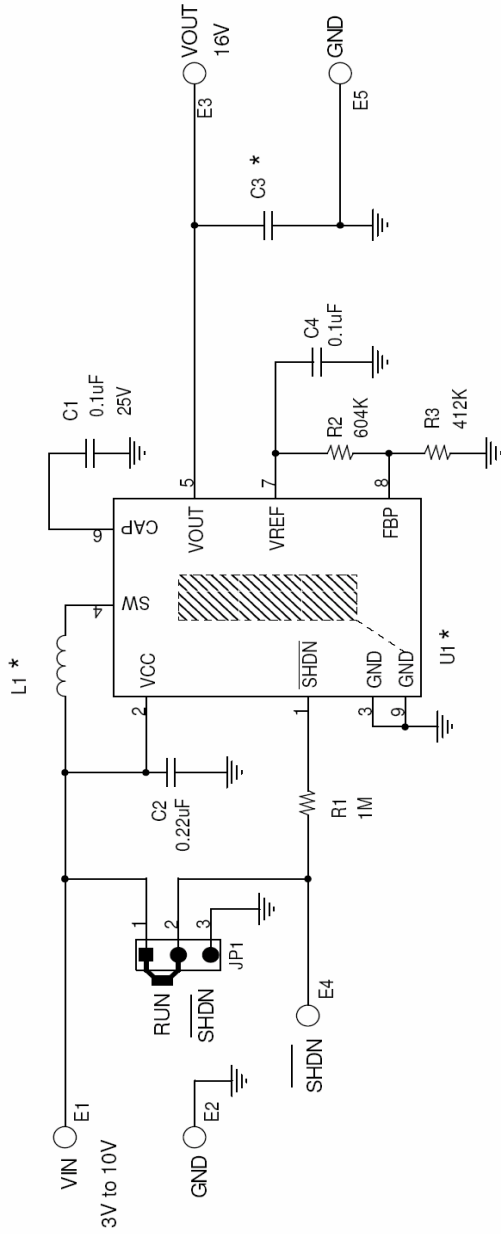

Figure 2. Measuring Input or output Ripple



\* VERSION TABLE

ASSEMBLY TYPE	Max Load at 3 V <sub>in</sub>	Max Load at 10 V <sub>in</sub>	U1	L1	C3
DC1387A-A	1.6 mA	10 mA	LT8410EDC	DO2010-104MLB	1uF
DC1387A-B	0.5 mA	3 mA	LT8410EDC-1	DO2010-224MLB	0.1uF

- NOTES: UNLESS OTHERWISE SPECIFIED
1. ALL RESISTORS ARE IN OHMS, 0402.
  2. INSTALL SHUNT ON JP1 PIN 1 AND 2.

**CUSTOMER NOTICE**

LINEAR TECHNOLOGY HAS MADE A BEST EFFORT TO DESIGN A CIRCUIT THAT MEETS CUSTOMER-SUPPLIED SPECIFICATIONS; HOWEVER, IT REMAINS THE CUSTOMER'S RESPONSIBILITY TO VERIFY PROPER AND RELIABLE OPERATION IN THE ACTUAL APPLICATION. COMPONENT SUBSTITUTION AND PRINTED CIRCUIT BOARD LAYOUT MAY SIGNIFICANTLY AFFECT CIRCUIT PERFORMANCE OR RELIABILITY. CONTACT LINEAR TECHNOLOGY APPLICATIONS ENGINEERING FOR ASSISTANCE

THIS CIRCUIT IS PROPRIETARY TO LINEAR TECHNOLOGY AND SUPPLIED FOR USE WITH LINEAR TECHNOLOGY PARTS.

**CONTRACT NO.**

**APPROVALS**

DRAWN: Antonina Mak

CHECKED:

APPROVED:

ENGINEER: JESUS R.

DESIGNER:



1630 McCarthy Blvd.  
Milpitas, CA 95035  
Phone: (408)432-1900  
Fax: (408)434-0507  
LTC Confidential-For Customer Use Only

TITLE: LT8410EDC, LT8410EDC-1

ULTRALOW POWER BOOST CONVERTER WITH OUTPUT DISCONNECT

SIZE	DWG NO.	REV
A	DC1387A	2

DATE: Wednesday, October 15, 2008

SHEET 1 OF 1