

THIS DRAWING IS UNPUBLISHED. RELEASED FOR PUBLICATION
 © COPYRIGHT - By - ALL RIGHTS RESERVED.

REVISIONS				
P	LTR	DESCRIPTION	DATE	APVD
T2		REVISED PER ECO-16-004223	05AUG2016	NK MZ

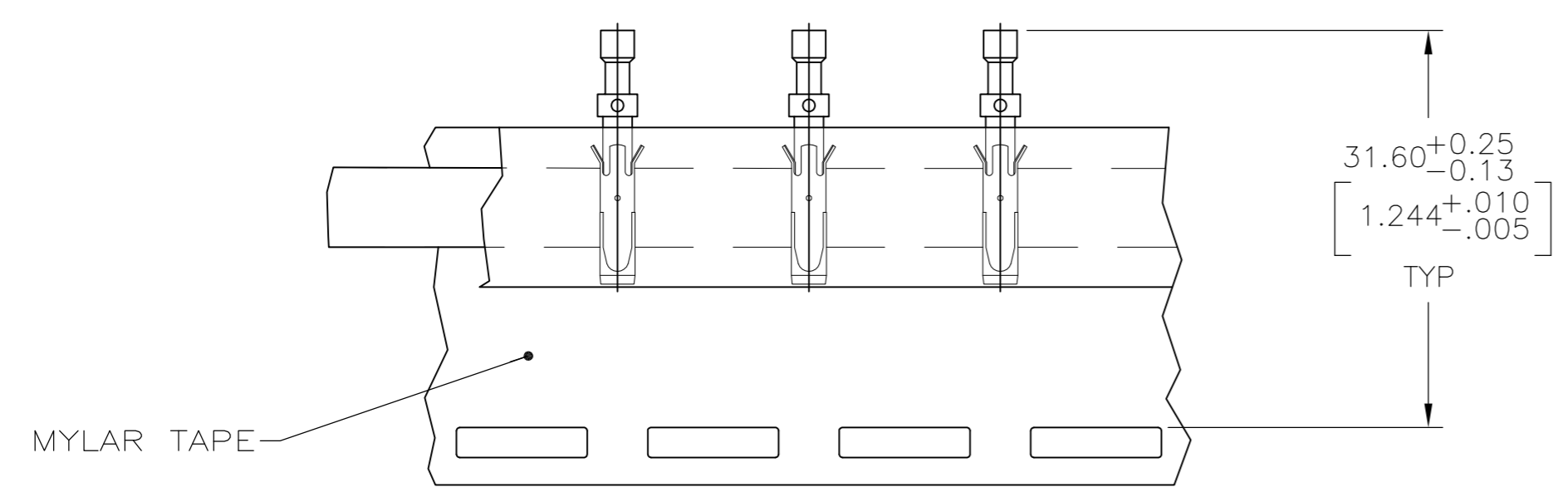
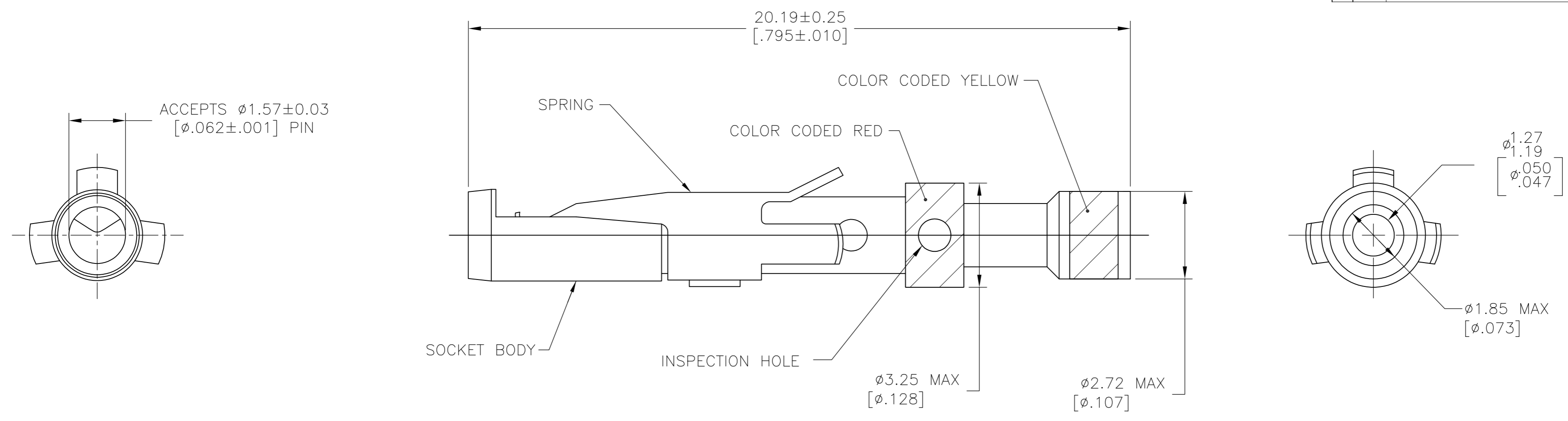

TAPE MTG DETAIL
SCALE 2:1

- ① 0.76 μ m [.000030] MIN GOLD OVER 1.27 μ m [.000050] MIN NICKEL.
- ② 2.54 μ m [.000100] MIN GOLD OVER 1.27 μ m [.000050] MIN NICKEL.
- ③ WHEN ORDERING CONTACT ASSEMBLY ON TAPE, ORDER BY THE TAPE NUMBER PLUS THE PACKAGING CODE AS FOLLOWS:
 1. FOR USE WITH AMP TAPETRONIC, PNEUMATIC TOOL-
A. 1000 PARTS TO A BOX ADD PACKAGING CODE: 1MBOX
 2. FOR USE WITH 4/8 INDENT STRIPPER CRIMPER-
A. 1000 PARTS TO A REEL ADD PACKAGING CODE: 1MREEL
B. 5000 PARTS TO A REEL ADD PACKAGING CODE: 5MREEL
- ④ OBSOLETE PARTS: OBSOLETE CIS STREAMLINING PER D.RENAUD/D.SINISI

④ OBSOLETE	SMALL PACK	①	-201580-9-
	TAPE MTG (SEE DETAIL)	③	-201580-7-
OBSOLETE	TAPE MTG (SEE DETAIL)	③	-201580-4-
	STANDARD	②	-201580-3-
	STANDARD	①	201580-1
	PACKAGING TYPE	SOCKET BODY FINISH	PART NUMBER

THIS DRAWING IS A CONTROLLED DOCUMENT.		DWN D.GELTZ 04/07/93	TE Connectivity	
DIMENSIONS: mm [INCHES]		CHK R.STONE 4-26-93		
TOLERANCES UNLESS OTHERWISE SPECIFIED:		APVD R.S.KLINE 4-29-93	NAME CONTACT ASSEMBLY, SOCKET, #16, 20-24 AWG, TYPE II	
0 PLC ± - 1 PLC ± - 2 PLC ± - 3 PLC ± - 4 PLC ± - ANGLES ± -		PRODUCT SPEC -	SIZE A2	CAGE CODE 00779
MATERIAL SOCKET BODY: COPPER ALLOY SPRING: STAINLESS STEEL		FINISH SOCKET BODY: SEE TABLE	DRAWING NO C=201580	RESTRICTED TO -
CUSTOMER DRAWING			SCALE 10:1	SHEET 1 OF 1