

THIS DRAWING IS UNPUBLISHED. RELEASED FOR PUBLICATION
© COPYRIGHT 19 BY - ALL RIGHTS RESERVED.

LOC	DIST	REVISIONS				
P	LTR	DESCRIPTION	DATE	DWN	APVD	
-	-	A	DRAWING RELEASE	31/7/07	NH	YP
		B	MODIF TIN BRACKET PLATING- CLARIFICATION	18JUN2013	JT	YP
		C	ADDED NOTE 1	22MAR2019	LN	YP

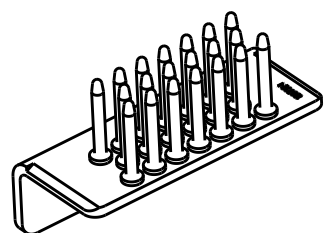

SCALE 1:1

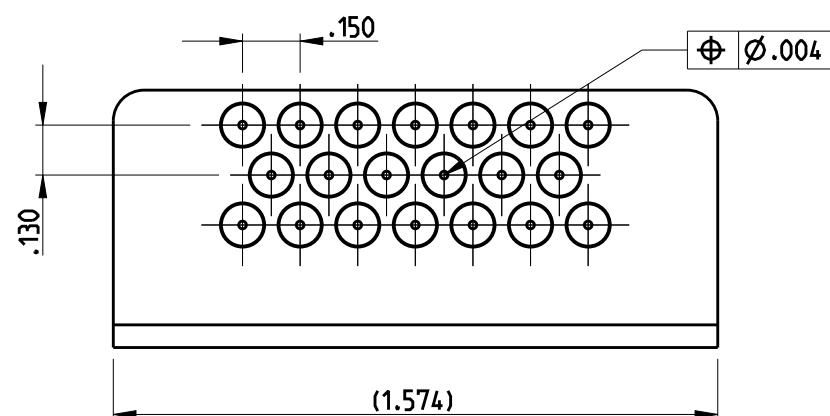
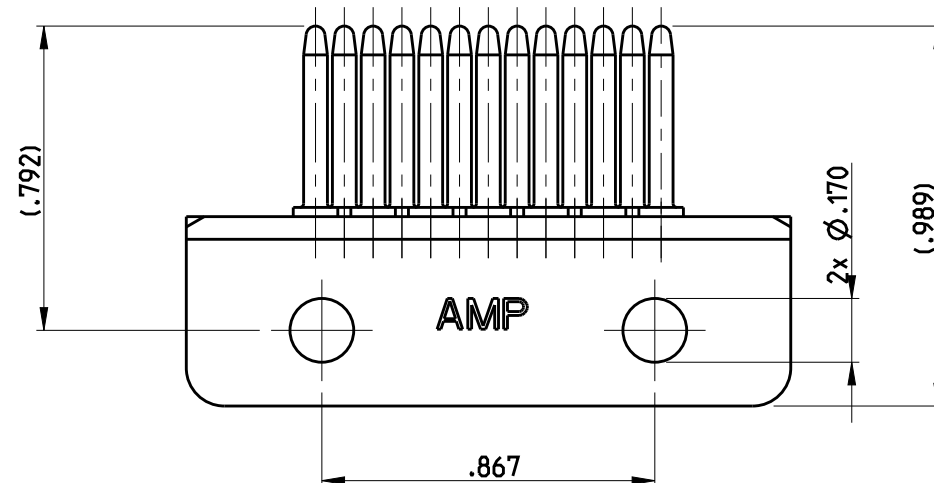
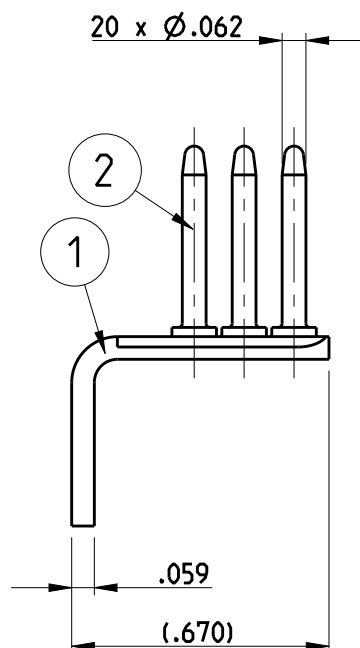
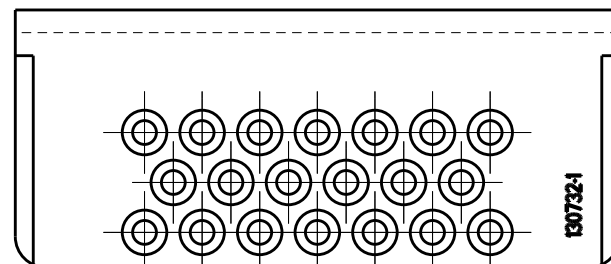

- 1. MATES TO 131435-3. 130733-2. 130733-4.
- 2 .000030 MIN AU OVER NICKEL.
- 3 .00016 MIN Sn. OVER Cu UNDERLAYER

FINISH	MATERIAL	QTY	PART DESCRIPTION	ITEM
2	BRASS	20	PIN	2
3	BRASS	1	BRACKET	1

130732-1
PART NUMBER

THIS DRAWING IS A CONTROLLED DOCUMENT.		DWN 31JULY2007 Niranjan Hegde	TE Connectivity	
DIMENSIONS: Inches		CHK 31JULY2007 Petronin Yves		
TOLERANCES UNLESS OTHERWISE SPECIFIED:		APVD 31JULY2007 Petronin Yves	NAME BRACKET GROUNDING 20 PIN	
0 PLC ±.1	1 PLC ±.02	PRODUCT SPEC	-	
2 PLC ±.005	3 PLC ±.005	APPLICATION SPEC	-	
4 PLC ±.005	ANGLES ±1°	WEIGHT 18 g	SIZE A3	CAGE CODE -
MATERIAL TABLE	FINISH TABLE	Customer Drawing	DRAWING NO C-130732	RESTRICTED TO -
			SCALE 2:1	SHEET 1 OF 1