

MICRO SWITCH

FREEMONT ILLINOIS, U.S.A.
A DIVISION OF HONEYWELL

FED. MFG. CODE 91929

ASSEMBLY- PUSHBUTTON SWITCH

CATALOG LISTING
IPB544

CATALOG LISTING
IPB544
PAGE 1 OF 1
M
DRAWING NUMBER
6
ISSUE
RELEASE NO. PR-8790
CHECK
REVISIONS
A PR 8790
D J S
23 MAY 80
B CO
53488
WJM
15 JUL 83
C 201143
CSL
1 SEP 00
D 201411
CSL
2 OCT 00
E 0018502
PM
27 FEB 06
CHECK
15 OCT 70
DRAWN
14 OCT 70
CHECK
MB S
3-50378-1A
RASTER

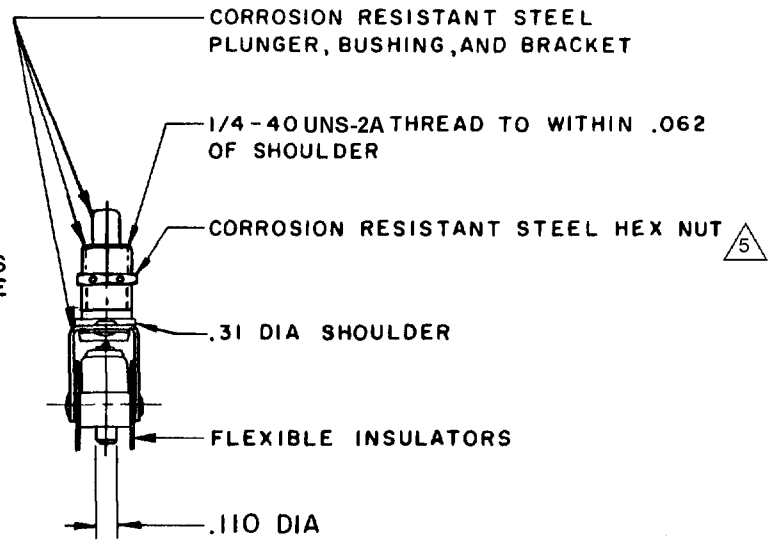
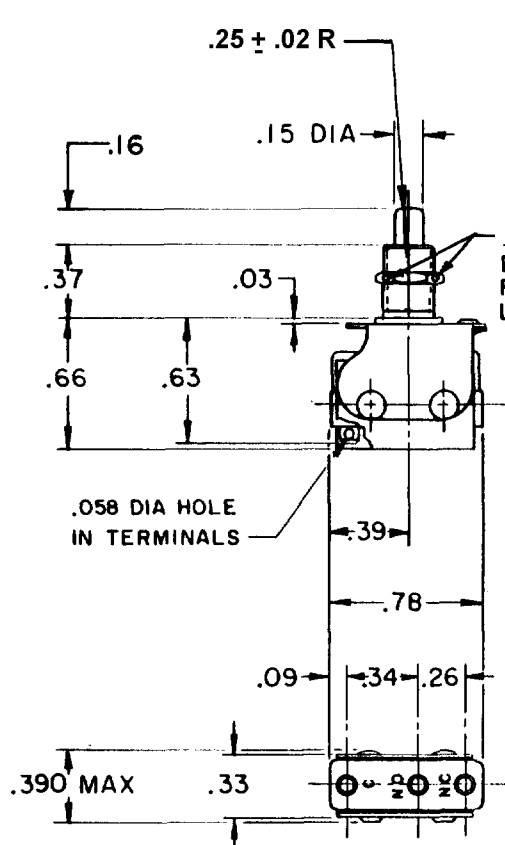

- NOTES**
- 1 - UNIT INCLUDES "11SM2446" TYPE BASIC SWITCH
 - 2 - TERMINALS ARE PLATED FOR SOLDERING
 - 3 - RECOMMENDED FOR MANUAL OPERATION ONLY
 - 4 - FOR USE IN TEMPERATURE RANGE -65° F TO +400° F
 - 5 MOUNTING HARDWARE FURNISHED UNASSEMBLED

THIS DRAWING COVERS A PROPRIETARY ITEM AND IS THE PROPERTY OF MICRO SWITCH, A DIVISION OF HONEYWELL. THIS DRAWING IS NOT TO BE COPIED OR USED WITHOUT THE APPROVAL OF MICRO SWITCH.

CHARACTERISTICS	ELECTRICAL DATA	SCALE FULL
OPERATING FORCE ----- 2 LBS MAX	CONTACT ARRANGEMENT S P D T	DO NOT SCALE PRINT
OVERTRAVEL FORCE ----- 2.5 LBS MAX	30 VOLTS DC RATING	UNLESS OTHERWISE NOTED DIMENSIONS ARE IN INCHES TOLERANCES ARE:
RELEASE FORCE ----- 2 OZ MIN		
OVERTRAVEL ----- .100 MIN	RESISTIVE ----- SEA LEVEL --- 5 AMP	ONE PLACE (.0) ± .030
DIFFERENTIAL TRAVEL ----- .031 MAX		TWO PLACE (.00) ± .015
		THREE PLACE (.000) ± .005
		ANGLES ±
		WEIGHT