

THIS DOCUMENT IS THE PROPERTY OF
KEYSTONE ELECTRONICS CORP. AND
SHALL NOT BE REPRODUCED, DISTRIBUTED
OR USED AS A BASIS FOR MANUFACTURE
WITHOUT PRIOR WRITTEN PERMISSION
FROM KEYSTONE ELECTRONICS CORP.

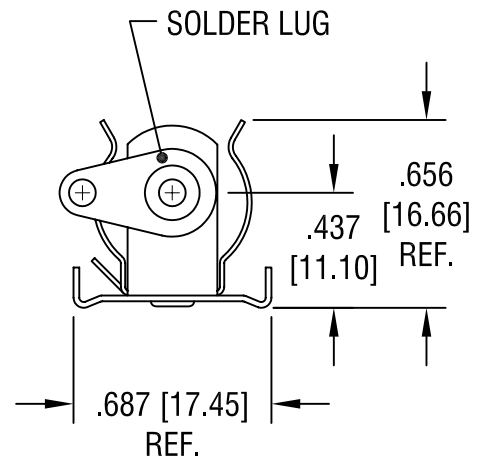
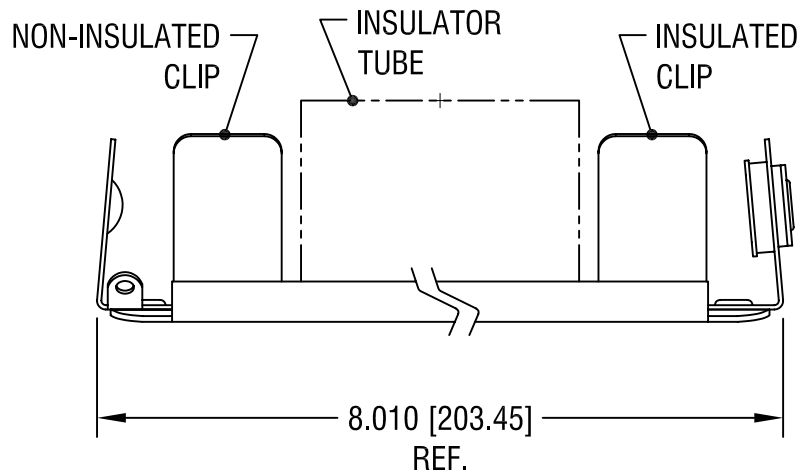
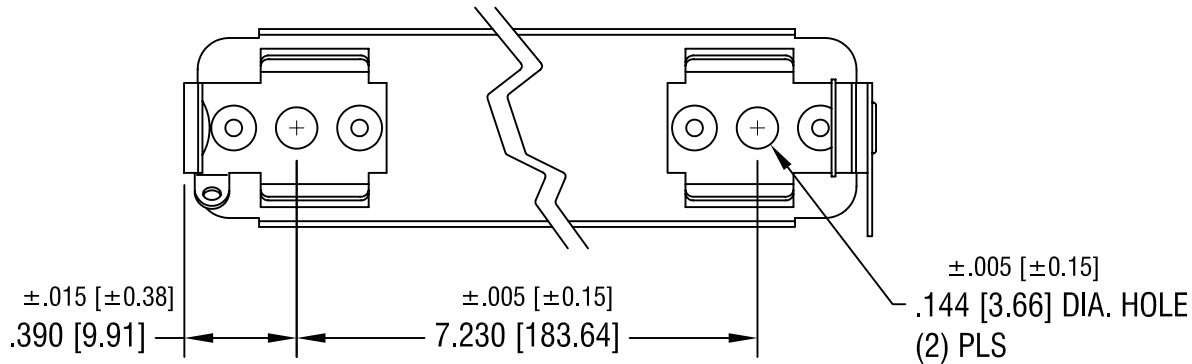

NOTES:

- 1. BASE: MAT'L - STAINLESS STEEL
- CLIP: MAT'L - SPRING STEEL
FINISH - NICKEL PLATE
- LUG: MAT'L - BRASS
FINISH - TIN PLATE
- TUBE: MAT'L - WOUND PAPER, BLACK

6.13.00	CHANGE AS PER ECN 00-047	B
11.12.97	CHANGE AS PER ECR 97-059	A
DATE	DESCRIPTION	REV.

KEYSTONE ELECTRONICS CORP.			
ASTORIA, N.Y. 11105-2017			
PART NAME			
NON-INSULATED BATTERY HOLDER, (4) 'AA'			
MATERIAL			
AS NOTED			
FINISH		DRN BY	DATE
AS NOTED		BOONE	4.5.82
		APP'D	SCALE
		LN	1.5X
TOLERANCES	INCH [MM]	CODE	DWG NO.
DECIMAL	$\pm .010 [\pm 0.25]$	C	1194
ANGULAR	$\pm 1^\circ$		
UNLESS OTHERWISE SPECIFIED			