

Gate Driver Providing Galvanic isolation Series

Isolation voltage 2500Vrms

1ch Gate Driver Providing Galvanic Isolation

**BM6104FV-C**

**General Description**

The BM6104FV-C is a gate driver with isolation voltage 2500Vrms, I/O delay time of 150ns, and minimum input pulse width of 90ns, and incorporates the fault signal output functions, undervoltage lockout (UVLO) function, and short current protection (SCP, DESAT) function.

**Key Specifications**

■ Isolation Voltage:	2500Vrms
■ Maximum Gate Drive Voltage:	24V
■ I/O Delay Time:	150ns(Max)
■ Minimum Input Pulse Width:	90ns(Max)

**Features**

- Providing Galvanic Isolation
- Active Miller Clamping
- Fault Signal Output Function (Adjustable Output Holding Time)
- Undervoltage Lockout Function
- Short Current Protection Function (Adjustable Reset Time)
- Soft Turn-Off Function For Short Current Protection (Adjustable Turn-Off Time)
- Supporting Negative VEE2
- Output State Feedback Function
- UL1577 Recognized:File No. E356010
- AEC-Q100 Qualified<sup>(Note 1)</sup> (Note 1:Grade1)

**Package**

SSOP-B20W

W(Typ) x D(Typ) x H(Max)  
6.50mm x 8.10mm x 2.01mm



**Applications**

- IGBT Gate Driver
- MOSFET Gate Driver

**Typical Application Circuits**

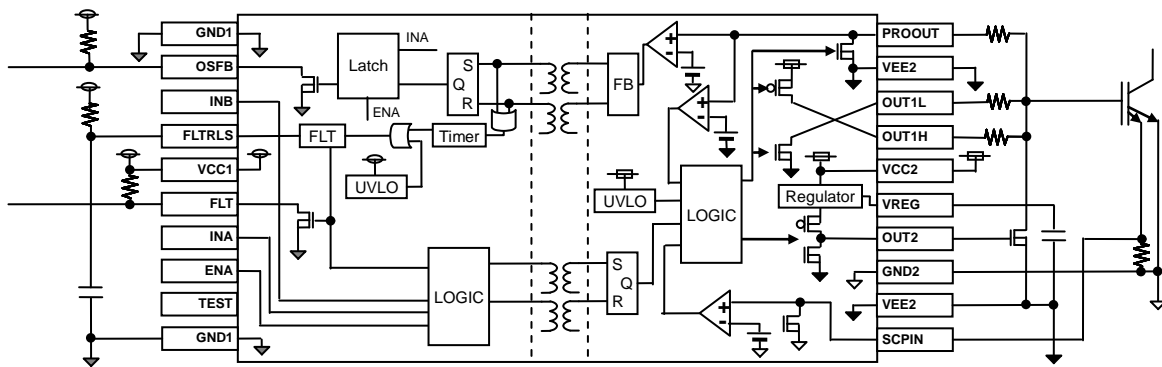

Figure 1. For using 4-pin IGBT (for using SCP function)

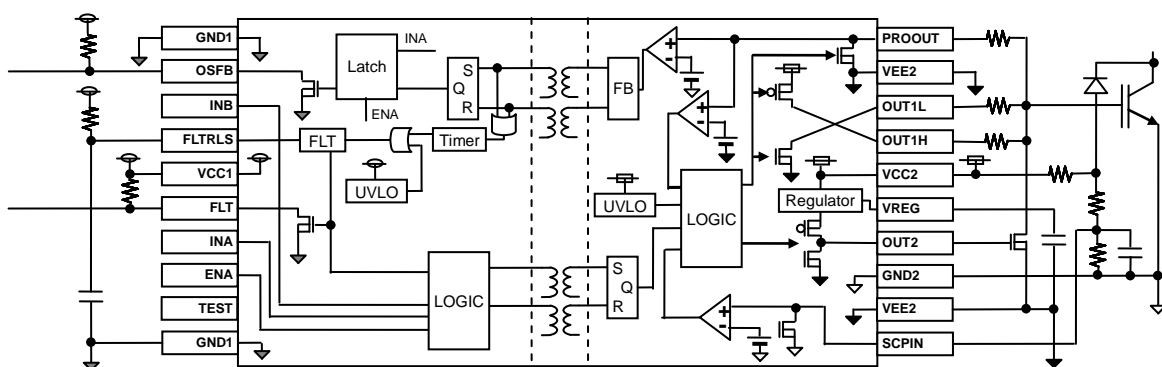

Figure 2. For using 3-pin IGBT (for using DESAT function)

Product structure : Silicon integrated circuit    This product is not designed protection against radioactive rays

## Recommended Range Of External Constants

Pin Name	Symbol	Recommended Value			Unit
		Min	Typ	Max	
FLTRLS	CFLTRLS	-	0.01	0.47	$\mu$ F
	RFLTRLS	50	200	1000	k $\Omega$
VREG	CVREG	1.0	3.3	10.0	$\mu$ F
VCC1	CVCC1	0.1	1.0	-	$\mu$ F
VCC2	CVCC2	0.33	-	-	$\mu$ F

## Pin Configurations

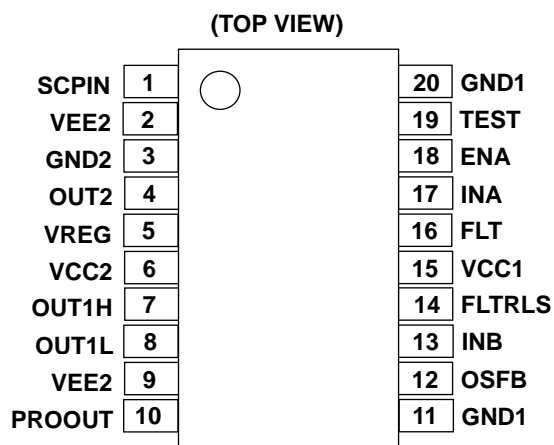

## Pin Descriptions

Pin No.	Pin Name	Function
1	SCPIN	Short current detection pin
2	VEE2	Output-side negative power supply pin
3	GND2	Output-side ground pin
4	OUT2	MOSFET control pin for Miller Clamp
5	VREG	Power supply pin for driving MOSFET for Miller Clamp
6	VCC2	Output-side positive power supply pin
7	OUT1H	Source side output pin
8	OUT1L	Sink side output pin
9	VEE2	Output-side negative power supply pin
10	PROOUT	Soft turn-off pin
11	GND1	Input-side ground pin
12	OSFB	Output state feedback output pin
13	INB	Control input pin B
14	FLTRLS	Fault output holding time setting pin
15	VCC1	Input-side power supply pin
16	FLT	Fault output pin
17	INA	Control input pin A
18	ENA	Input enabling signal input pin
19	TEST	Mode setting pin
20	GND1	Input-side ground pin

**Description of pins and cautions on layout of board**

## 1) VCC1 (Input-side power supply pin)

The VCC1 pin is a power supply pin on the input side. To suppress voltage fluctuations due to the current to drive internal transformers, connect a bypass capacitor between the VCC1 and the GND1 pins.

## 2) GND1 (Input-side ground pin)

The GND1 pin is a ground pin on the input side.

## 3) VCC2 (Output-side positive power supply pin)

The VCC2 pin is a positive power supply pin on the output side. To reduce voltage fluctuations due to OUT1H/L pin output current and due to the current to drive internal transformers, connect a bypass capacitor between the VCC2 and the GND2 pins.

## 4) VEE2 (Output-side negative power supply pin)

The VEE2 pin is a power supply pin on the output side. To suppress voltage fluctuations due to OUT1H/L pin output current and due to the current to drive internal transformers, connect a bypass capacitor between the VEE2 and the GND2 pins. To use no negative power supply, connect the VEE2 pin to the GND2 pin.

## 5) GND2 (Output-side ground pin)

The GND2 pin is a ground pin on the output side. Connect the GND2 pin to the emitter / source of a power device.

## 6) IN (Control input terminal)

The IN is a pin used to determine output logic.

ENA	INB	INA	OUT1H	OUT1L
H	X	X	Hi-Z	L
L	H	L	Hi-Z	L
L	H	H	Hi-Z	L
L	L	L	Hi-Z	L
L	L	H	H	Hi-Z

## 7) FLT (Fault output pin)

The FLT pin is an open drain pin used to output a fault signal when a fault occurs (i.e., when the undervoltage lockout function (UVLO) or short current protection function (SCP) is activated).

Pin	FLT
While in normal operation	Hi-Z
When an Fault occurs (When UVLO or SCP is activated)	L

## 8) FLTRLS (Fault output holding time setting pin)

The FLTRLS is a pin used to make setting of time to hold a Fault signal. Connect a capacitor between the FLTRLS pin and the GND1 pin, and a resistor between it and the VCC1 pin.

The Fault signal is held until the FLTRLS pin voltage exceeds a voltage set with the  $V_{FLTRLS}$  parameter. To set holding time to 0 ms, do not connect the capacitor. Short-circuiting the FLTRLS pin to the VCC1 pin will cause a high current to flow in the FLTRLS pin and, in an open state, may cause the IC to malfunction. To avoid such trouble, be sure to connect a resistor between the FLTRLS and the VCC1 pins.

## 9) OUT1H, OUT1L (Output pin)

The OUT1H pin is a source side pin used to drive the gate of a power device, and the OUT1L pin is a sink side pin used to drive the gate of a power device.

## 10) OUT2 (MOSFET control pin for Miller Clamp)

The OUT2 is a pin for controlling the external MOS switch to prevent the increase in gate voltage due to the miller current of the power device connected to OUT1H/L pin.

## 11) VREG (Power supply pin for driving the MOSFET for Miller Clamp)

The VREG pin is a power supply pin for Miller Clamp (typ 10V). Be sure to connect a capacitor between VREG pin and VEE2 pin to prevent oscillation and to reduce voltage fluctuations due to OUT2 pin output current.

## 12) PROOUT (Soft turn-off pin)

The PROOUT is a pin used to put the soft turn-off function of a power device in operation when the SCP function is activated. This pin combines with the gate voltage monitoring pin for Miller Clamp function and OSFB function which output the gate state.

## 13) SCPIN (Short current detection pin)

The SCPIN is a pin used to detect current for short current protection. When the SCPIN pin voltage exceeds  $V_{SCDET}$  (typ 0.7V), the SCP function will be activated. This may cause the IC to malfunction in an open state. To avoid such trouble, short-circuit the SCPIN pin to the GND2 pin if the short current protection is not used. In order to prevent the wrong detection due to noise, the noise mask time  $t_{SCPMASK}$  (typ 0.8 $\mu$ s) is set.

14) OSFB (Output state feedback output pin)

The OSFB pin is an open drain pin used to output the gate state. If the IN and the OUT1H/L pin are at the same level, the OSFB pin output the "Hi-Z" level, otherwise the OSFB pin output the "L" level and hold "L" until ENA=H or UVLO on low voltage side is activated.

15) TEST (Mode setting pin)

The TEST pin is an operation mode setting pin. This pin is usually connected to GND1 pin. If the TEST pin is connected to the VCC1 pin, Input-side UVLO function is disabled.

**Description of functions and examples of constant setting**

1) Miller Clamp function

When OUT1H/L=Hi-Z/L and PROOUT pin voltage <  $V_{OUT2ON}$  (typ 2V), H is output from OUT2 pin and the external MOS switch is turned ON. When OUT1H/L=H/Hi-Z, L is output from OUT2 pin and the external MOS switch is turned OFF. While the short-circuit protection function is activated, L is output from OUT2 pin and the external MOS switch is turned OFF.

Short current	SCPIN	IN	PROOUT	OUT2
Detected	Not less than $V_{SCDET}$	X	X	L
Not detected	X	L	Not less than $V_{OUT2ON}$	L
	X	L	less than $V_{OUT2ON}$	H
	X	H	X	L

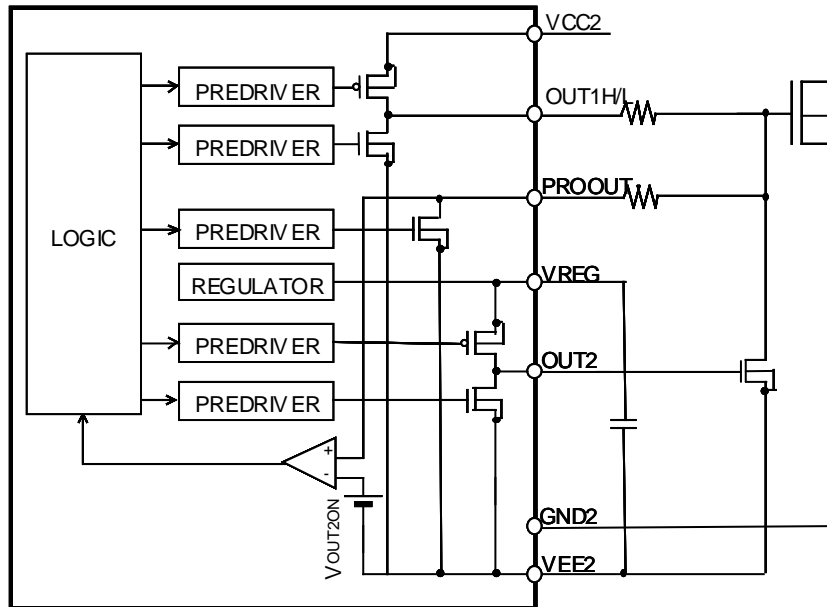

Figure 3. Block diagram of Miller Clamp function.

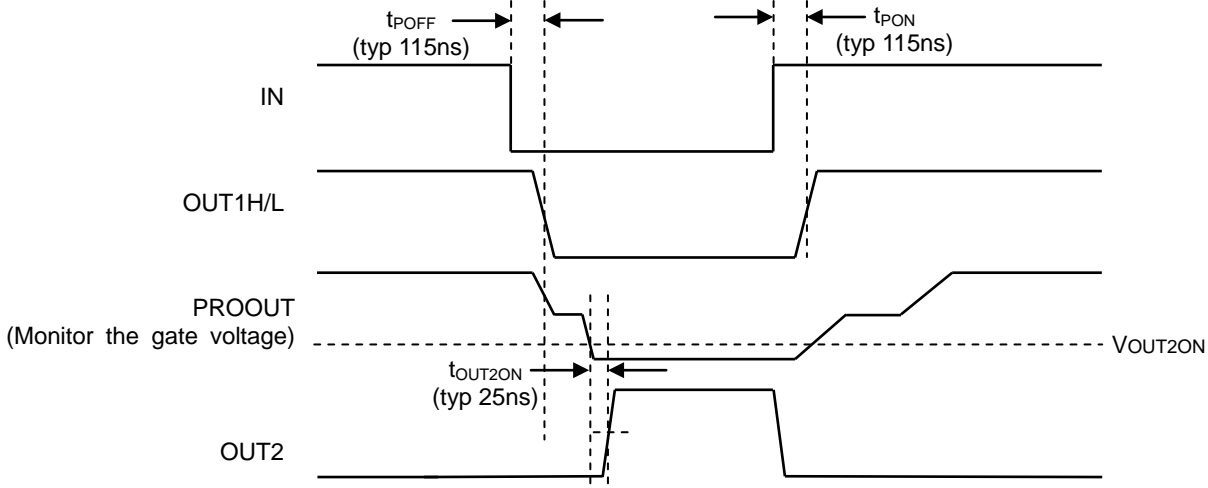

Figure 4. Timing chart of Miller Clamp function

2) Fault status output

This function is used to output a fault signal from the FLT pin when a fault occurs (i.e., when the undervoltage lockout function (UVLO) or short current protection function (SCP) is activated) and hold the Fault signal until the set Fault output holding time is completed. The Fault output holding time  $t_{FLTRLS}$  is given as the following equation with the settings of capacitor  $C_{FLTRLS}$  and resistor  $R_{FLTRLS}$  connected to the FLTRLS pin. For example, when  $C_{FLTRLS}$  is set to  $0.01\mu F$  and  $R_{FLTRLS}$  is set to  $200k\Omega$ , the holding time will be set to 2 ms.

$$t_{FLTRLS} [ms] = C_{FLTRLS} [\mu F] \cdot R_{FLTRLS} [k\Omega]$$

To set the fault output holding time to "0" ms, only connect the resistor  $R_{FLTRLS}$ .

Status	FLT pin
Normal	Hi-Z
Fault occurs	L

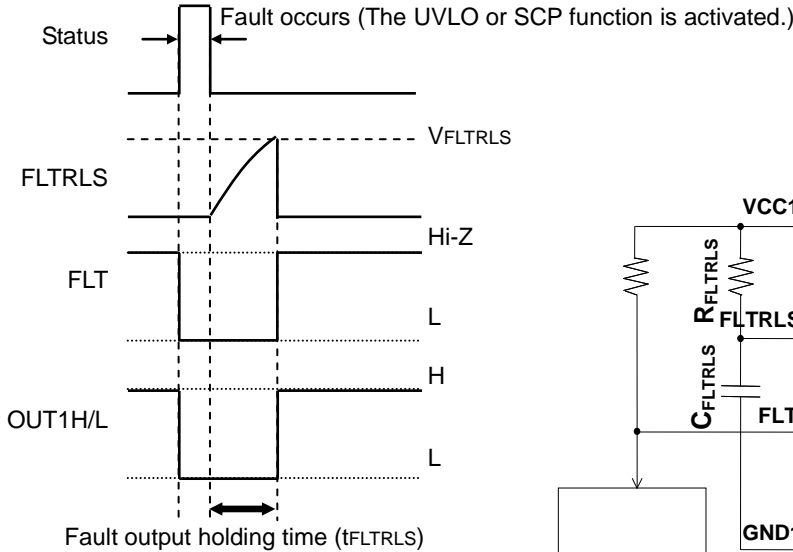

Figure 5. Fault Status Output Timing Chart

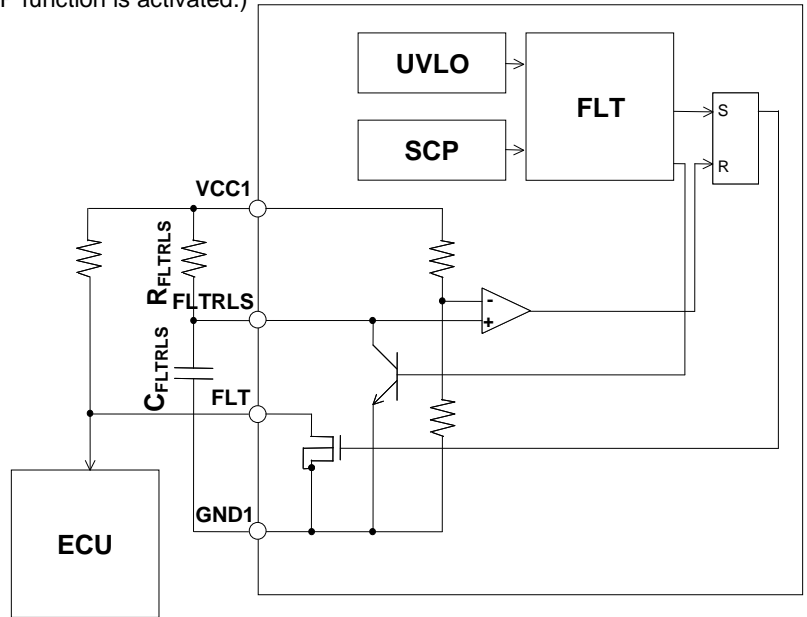

Figure 6. Fault Output Block Diagram

3) Undervoltage Lockout (UVLO) function

The BM6104FV-C incorporates the undervoltage lockout (UVLO) function both on the low and the high voltage sides. When the power supply voltage drops to the UVLO ON voltage (low voltage side typ 3.4V, high voltage side typ 9.05V), the OUT1 and the FLT pin both will output the "L" signal. When the power supply voltage rises to the UVLO OFF voltage (low voltage side typ 3.5V, high voltage side typ 9.55V), these pins will be reset. However, during the fault output holding time set in "2) Fault status output" section, the OUT1 pin and the FLT pin will hold the "L" signal. In addition, to prevent malfunctions due to noises, mask time  $t_{UVLO1MSK}$  (typ 10 $\mu s$ ) and  $t_{UVLO2MSK}$  (typ 10 $\mu s$ ) are set on both low and high voltage sides.

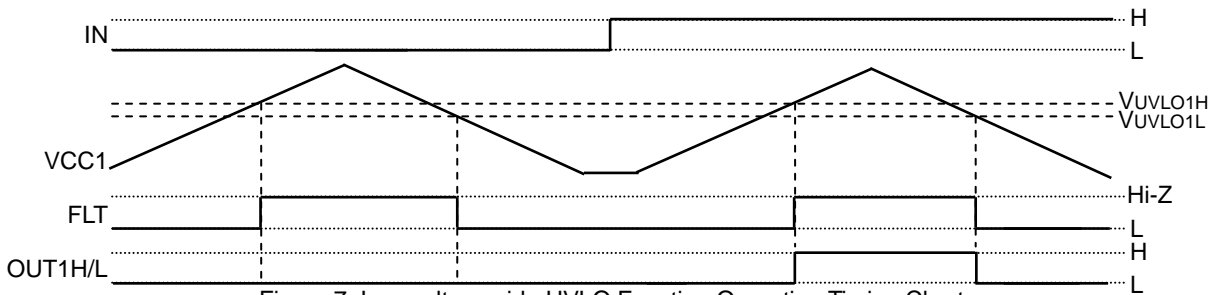

Figure 7. Low voltage side UVLO Function Operation Timing Chart

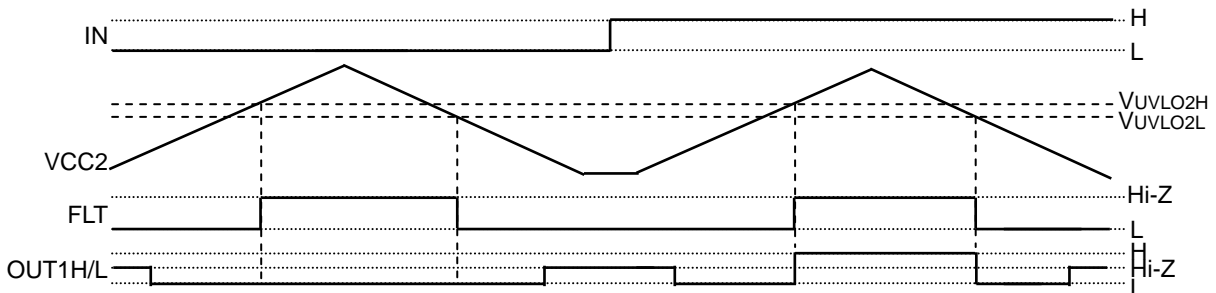

Figure 8. High voltage side UVLO Operation Timing Chart

4) Short current protection function (SCP, DESAT)

When the SCPIN pin voltage exceeds  $V_{SCDET}$  (typ 0.7V), the SCP function will be activated. When the SCP function is activated, the OUT1H/L pin voltage will be set to the "Hi-Z/HiZ" level first, and then the PROOUT pin voltage to the "L" level (soft turn-off). Next, after  $t_{STO}$  (min 30µs, max 110µs) has passed after the short-circuit current falls below the threshold value, OUT1H/L pin becomes HiZ/L and PROOUT pin becomes L. Finally, when the fault output holding time set in "2) fault status output" section on page 5 is completed, the SCP function will be released.

$V_{COLLECTOR}/V_{DRAIN}$  which Desaturation Protection starts operation ( $V_{DESAT}$ ) and the blanking time ( $t_{BLANK}$ ) can be calculated by the formula below;

$$V_{DESAT} [V] = V_{SCDET} \cdot \frac{R3 + R2}{R3} - V_{FD1}$$

$$V_{CC2\_MIN} [V] > V_{SCDET} \cdot \frac{R3 + R2 + R1}{R3}$$

$$t_{BLANK\text{outemal}} [s] = -\frac{R2 + R1}{R3 + R2 + R1} \cdot R3 \cdot (C_{BLANK} + 24 \cdot 10^{-12}) \cdot \ln\left(1 - \frac{R3 + R2 + R1}{R3} \cdot \frac{V_{SCDET}}{V_{CC2}}\right) + 0.2 \cdot 10^{-6}$$

$V_{DESAT}$	Reference Value		
	R1	R2	R3
4.0V	15 kΩ	39 kΩ	6.8 kΩ
4.5V	15 kΩ	43 kΩ	6.8 kΩ
5.0V	15 kΩ	36 kΩ	5.1 kΩ
5.5V	15 kΩ	39 kΩ	5.1 kΩ
6.0V	15 kΩ	43 kΩ	5.1 kΩ
6.5V	15 kΩ	62 kΩ	6.8 kΩ
7.0V	15 kΩ	68 kΩ	6.8 kΩ
7.5V	15 kΩ	82 kΩ	7.5 kΩ
8.0V	15 kΩ	91 kΩ	8.2 kΩ
8.5V	15 kΩ	82 kΩ	6.8 kΩ
9.0V	15 kΩ	130 kΩ	10 kΩ
9.5V	15 kΩ	91 kΩ	6.8 kΩ
10.0V	15 kΩ	130 kΩ	9.1 kΩ

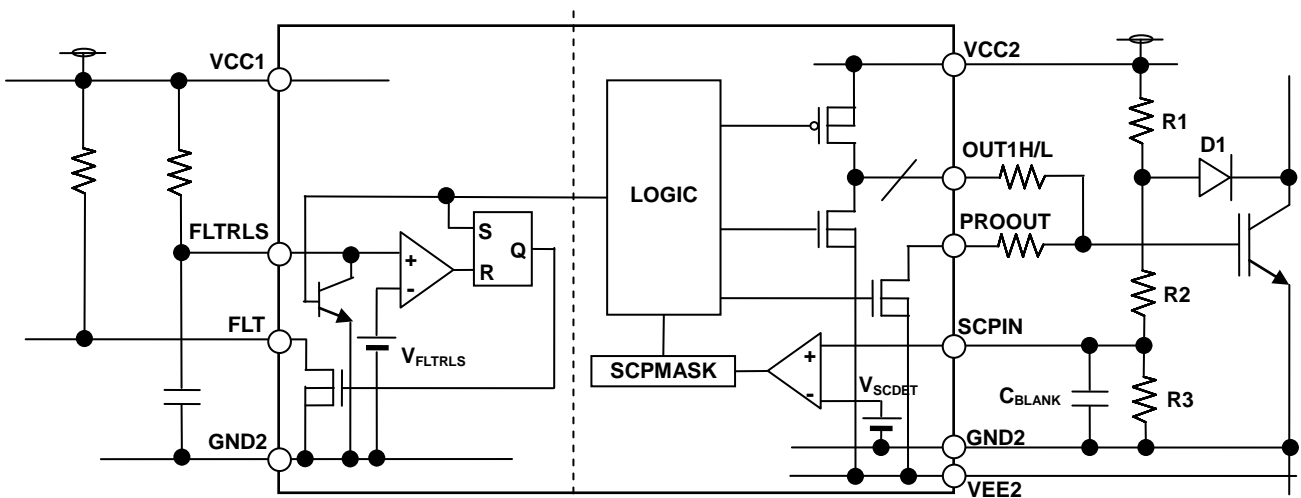

Figure 9. Block Diagram for DESAT

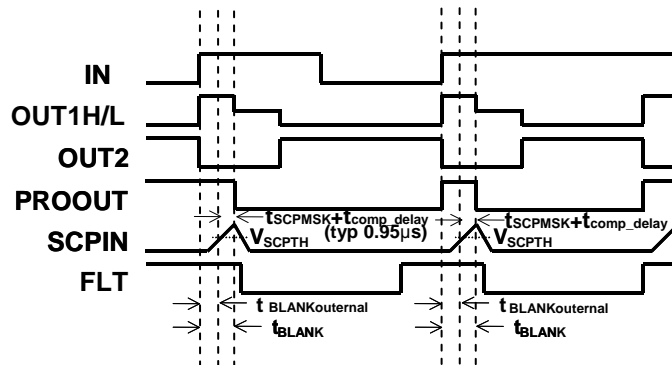
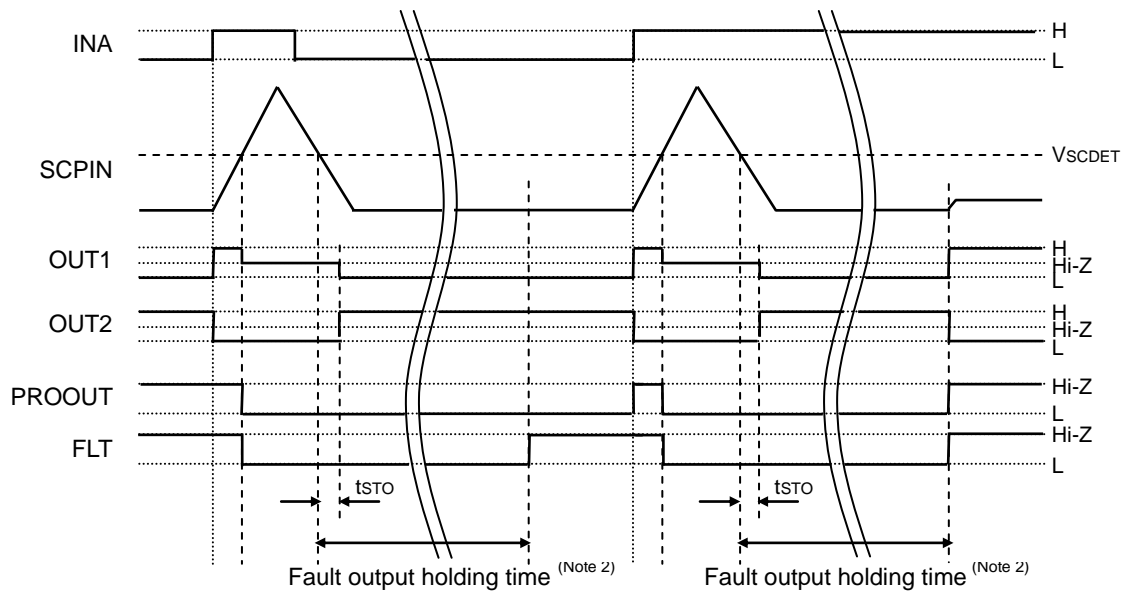

Figure 10. DESAT Operation Timing Chart



(Note 2): "2) Fault status output" section on page 5

Figure 11. SCP Operation Timing Chart

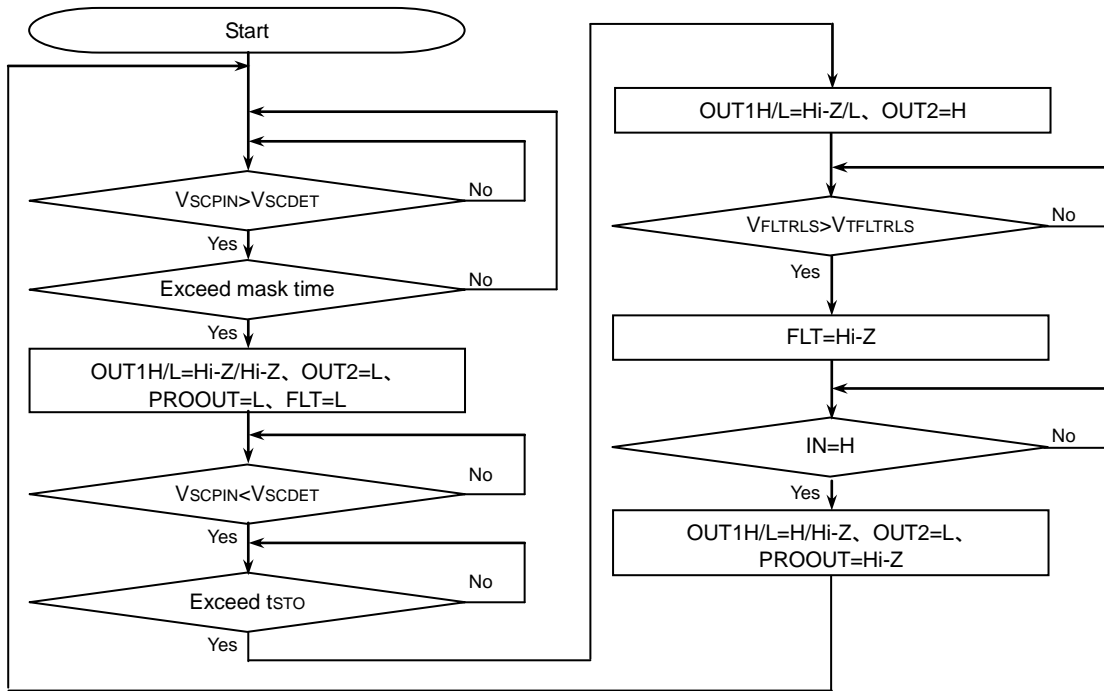

Figure 12. SCP Operation Status Transition Diagram

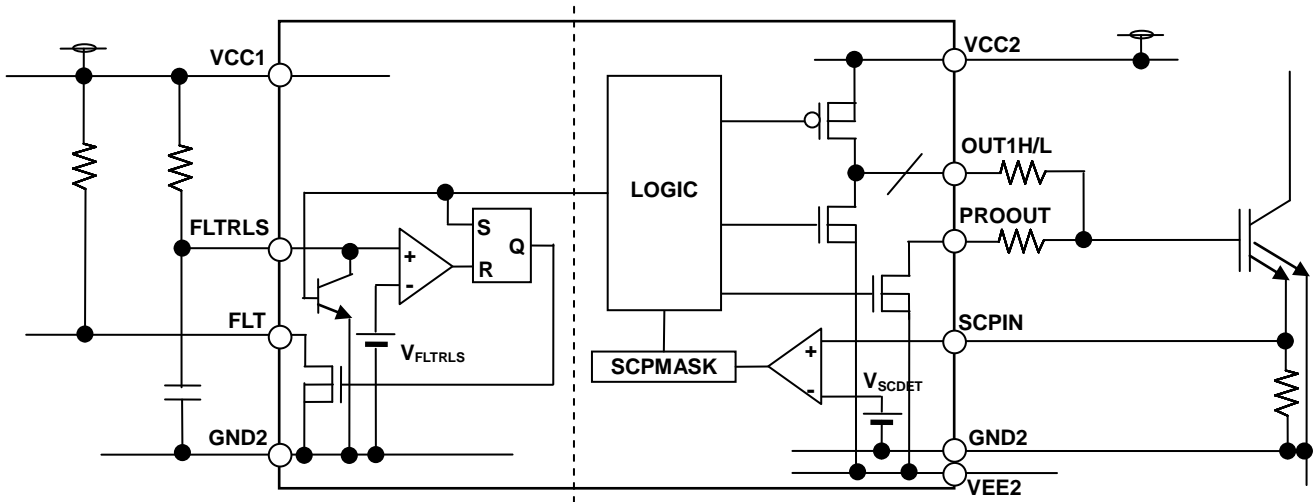

Figure 13. Block Diagram for SCP



5) I/O condition table

No	Status	Input							Output					
		VCC1	VCC2	SCPIN	EN A	IN B	IN A	PROOUT	OUT1H	OUT1L	OUT2	PROOUT	FLT	OSFB
1	SCP	O	O	H	L	L	H	X	Hi-Z	Hi-Z	L	L	L	Hi-Z
2	VCC1UVLO	UVLO	X	L	X	X	X	H	Hi-Z	L	L	Hi-Z	L	Hi-Z
3		UVLO	X	L	X	X	X	L	Hi-Z	L	H	Hi-Z	L	Hi-Z
4	VCC2UVLO	X	UVLO	L	X	X	X	H	Hi-Z	L	L	Hi-Z	L	Hi-Z
5		X	UVLO	L	X	X	X	L	Hi-Z	L	H	Hi-Z	L	Hi-Z
6	Disable	O	O	L	H	X	X	H	Hi-Z	L	L	Hi-Z	Hi-Z	Hi-Z
7		O	O	L	H	X	X	L	Hi-Z	L	H	Hi-Z	Hi-Z	Hi-Z
8	INB Active	O	O	L	L	H	X	H	Hi-Z	L	L	Hi-Z	Hi-Z	L
9		O	O	L	L	H	X	L	Hi-Z	L	H	Hi-Z	Hi-Z	Hi-Z
10	Normal Operation L Input	O	O	L	L	L	L	H	Hi-Z	L	L	Hi-Z	Hi-Z	L
11		O	O	L	L	L	L	L	Hi-Z	L	H	Hi-Z	Hi-Z	Hi-Z
12	Normal Operation H Input	O	O	L	L	L	H	H	H	Hi-Z	L	Hi-Z	Hi-Z	Hi-Z
13		O	O	L	L	L	H	L	H	Hi-Z	L	Hi-Z	Hi-Z	L

O: VCC1 or VCC2 &gt; UVLO, X: Don't care

6) Power supply startup / shutoff sequence

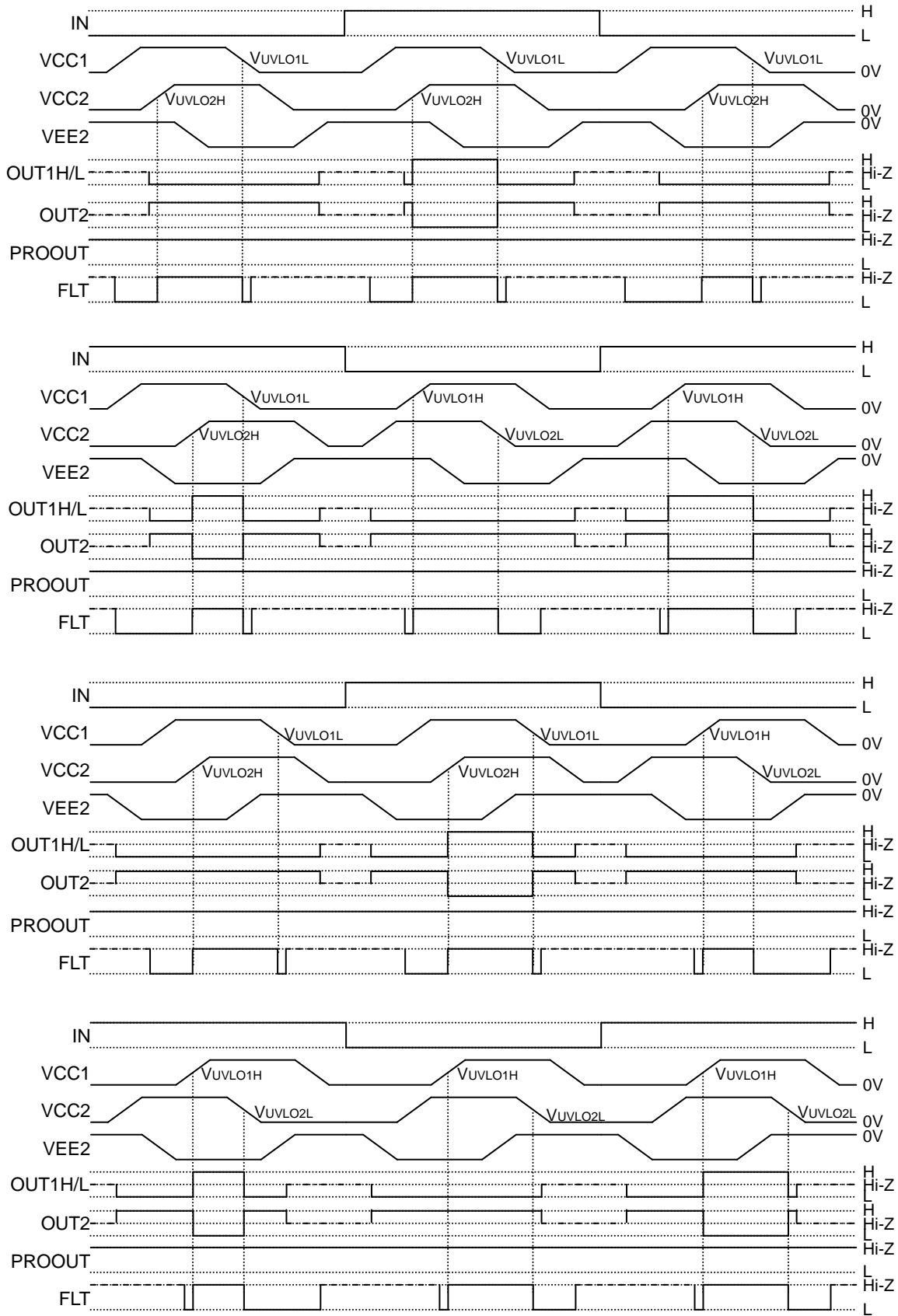

----- : Since the VCC2 to VEE2 pin voltage is low and the output MOS does not turn ON, the output pins become Hi-Z conditions.  
 ----- : Since the VCC1 pin voltage is low and the FLT output MOS does not turn ON, the output pins become Hi-Z conditions.

Figure 14. Power supply startup / shutoff sequence

## Absolute Maximum Ratings

Parameter	Symbol	Limits	Unit
Input-Side Supply Voltage	$V_{CC1}$	$-0.3 \sim +7.0$ <sup>(Note 3)</sup>	V
Output-Side Positive Supply Voltage	$V_{CC2}$	$-0.3 \sim +30.0$ <sup>(Note 4)</sup>	V
Output-Side Negative Supply Voltage	$V_{EE2}$	$-15.0 \sim +0.3$ <sup>(Note 4)</sup>	V
Maximum Difference Between Output-Side Positive and Negative Voltages	$V_{MAX2}$	36.0	V
INA, INB, ENA Pin Input Voltage	$V_{IN}$	$-0.3 \sim +V_{CC1}+0.3$ or $7.0$ <sup>(Note 3)</sup>	V
OSFB, FLT Pin Input Voltage	$V_{FLT}$	$-0.3 \sim +V_{CC1}+0.3$ or $7.0$ <sup>(Note 3)</sup>	V
FLTRLS Pin Input Voltage	$V_{FLTRLS}$	$-0.3 \sim +V_{CC1}+0.3$ or $7.0$ <sup>(Note 3)</sup>	V
SCPIN Pin Input Voltage	$V_{SCPIN}$	$-0.3 \sim -V_{CC2}+0.3$ <sup>(Note 4)</sup>	V
VREG Pin Output Current	$I_{VREG}$	10	mA
OUT1H, OUT1L, PROOUT Pin Output Current (Peak 10 $\mu$ s)	$I_{OUT1PEAK}$	5.0 <sup>(Note 5)</sup>	A
OUT2 Pin Output Current (Peak 10 $\mu$ s)	$I_{OUT2PEAK}$	1.0 <sup>(Note 5)</sup>	A
OSFB Output Current	$I_{OSFB}$	10	mA
FLT Output Current	$I_{FLT}$	10	mA
Power Dissipation	$P_d$	1.19 <sup>(Note 6)</sup>	W
Operating Temperature Range	$T_{opr}$	$-40 \sim +125$	$^{\circ}$ C
Storage Temperature Range	$T_{stg}$	$-55 \sim +150$	$^{\circ}$ C
Junction Temperature	$T_{jmax}$	+150	$^{\circ}$ C

(Note 3) Relative to GND1.

(Note 4) Relative to GND2.

(Note 5) Should not exceed  $P_d$  and  $T_j=150^{\circ}$ C.(Note 6) Derate above  $T_a=25^{\circ}$ C at a rate of 9.5mW/ $^{\circ}$ C. Mounted on a glass epoxy of 70 mm  $\times$  70 mm  $\times$  1.6 mm.

**Caution:** Operating the IC over the absolute maximum ratings may damage the IC. The damage can either be a short circuit between pins or an open circuit between pins and the internal circuitry. Therefore, it is important to consider circuit protection measures, such as adding a fuse, in case the IC is operated over the absolute maximum ratings.

## Recommended Operating Ratings

Parameter	Symbol	Min	Max	Units
Input-Side Supply Voltage <sup>(Note 7)</sup>	$V_{CC1}$	4.5	5.5	V
Output-Side Positive Supply Voltage <sup>(Note 8)</sup>	$V_{CC2}$	10	24	V
Output-Side Negative Supply Voltage <sup>(Note 8)</sup>	$V_{EE2}$	-12	0	V
Maximum Difference Between Output-Side Positive and Negative Voltages	$V_{MAX2}$	10	32	V

(Note 7) Relative to GND1.

(Note 8) Relative to GND2.

## Insulation Related Characteristics

Parameter	Symbol	Characteristic	Units
Insulation Resistance ( $V_{IO}=500V$ )	$R_s$	$>10^9$	$\Omega$
Insulation Withstand Voltage / 1min	$V_{ISO}$	2500	Vrms
Insulation Test Voltage / 1sec	$V_{ISO}$	3000	Vrms

**Electrical Characteristics**(Unless otherwise specified  $T_a = -40^{\circ}\text{C} \sim 125^{\circ}\text{C}$ ,  $V_{CC1} = 4.5\text{V} \sim 5.5\text{V}$ ,  $V_{CC2} = 10\text{V} \sim 24\text{V}$ ,  $V_{EE2} = -12\text{V} \sim 0\text{V}$ )

Parameter	Symbol	Min	Typ	Max	Unit	Conditions
<b>General</b>						
Input Side Circuit Current 1	$I_{CC11}$	0.38	0.51	0.64	mA	OUT1=L
Input Side Circuit Current 2	$I_{CC12}$	0.38	0.51	0.64	mA	OUT1=H
Input Side Circuit Current 3	$I_{CC13}$	0.47	0.62	0.77	mA	INA=10kHz, Duty=50%
Input Side Circuit Current 4	$I_{CC14}$	0.54	0.72	0.90	mA	INA=20kHz, Duty=50%
Output Side Circuit Current 1	$I_{CC21}$	1.5	2.0	2.5	mA	VCC2=14V, OUT1=L
Output Side Circuit Current 2	$I_{CC22}$	1.3	1.8	2.3	mA	VCC2=14V, OUT1=H
Output Side Circuit Current 3	$I_{CC23}$	1.6	2.2	2.8	mA	VCC2=18V, OUT1=L
Output Side Circuit Current 4	$I_{CC24}$	1.3	1.9	2.5	mA	VCC2=18V, OUT1=H
Output Side Circuit Current 5	$I_{CC25}$	1.8	2.5	3.2	mA	VCC2=24V, OUT1=L
Output Side Circuit Current 6	$I_{CC26}$	1.5	2.1	2.7	mA	VCC2=24V, OUT1=H
<b>Logic Block</b>						
Logic High Level Input Voltage	$V_{INH}$	2.0	-	$V_{CC1}$	V	INA, INB, ENA
Logic Low Level Input Voltage	$V_{INL}$	0	-	0.8	V	INA, INB, ENA
Logic Pull-Down Resistance	$R_{IND}$	25	50	100	k $\Omega$	INA, INB
Logic Pull-Up Resistance	$R_{INU}$	25	50	100	k $\Omega$	ENA
Logic Input Mask Time	$t_{INMSK}$	-	-	90	ns	INA, INB
ENA Mask Time	$t_{ENAMSK}$	4	10	20	$\mu\text{s}$	ENA
<b>Output</b>						
OUT1H ON Resistance	$R_{ONH}$	0.7	1.8	4.0	$\Omega$	IOUT1H=40mA
OUT1L ON Resistance	$R_{ONL}$	0.4	0.9	2.0	$\Omega$	IOUT1L=40mA
OUT1 Maximum Current	$I_{OUTMAX}$	3.0	4.5	-	A	VCC2=18V Guaranteed by design
PROOUT ON Resistance	$R_{ONPRO}$	0.4	0.9	2.0	$\Omega$	IPROOUT=40mA
Turn ON Time	$t_{PONA}$	90	115	150	ns	INA=PWM, INB=L
	$t_{PONB}$	100	125	160	ns	INA=H, INB=PWM
Turn OFF Time	$t_{POFFA}$	90	115	150	ns	INA=PWM, INB=L
	$t_{POFFB}$	80	105	140	ns	INA=H, INB=PWM
Propagation Distortion	$t_{PDISTA}$	-25	0	20	ns	$t_{POFFA} - t_{PONA}$
	$t_{PDISTB}$	-45	-20	0	ns	$t_{POFFB} - t_{PONB}$
Rise Time	$t_{RISE}$	-	50	-	ns	10nF between OUT1-VEE2
Fall Time	$t_{FALL}$	-	50	-	ns	10nF between OUT1-VEE2
OUT2 ON Resistance (Source)	$R_{ON2H}$	2.0	4.5	9.0	$\Omega$	IOUT2=10mA
OUT2 ON Resistance (Sink)	$R_{ON2L}$	1.5	3.5	7.0	$\Omega$	IOUT2=10mA
OUT2 ON Threshold Voltage	$V_{OUT2ON}$	1.8	2	2.2	V	Relative to VEE2
OUT2 Output Delay Time	$t_{OUT2ON}$	-	25	50	ns	
VREG Output Voltage	$V_{REG}$	9	10	11	V	Relative to VEE2
Common Mode Transient Immunity	CM	100	-	-	kV/ $\mu\text{s}$	Design assurance

**Electrical Characteristics**

(Unless otherwise specified  $T_a = -40^{\circ}\text{C} \sim 125^{\circ}\text{C}$ ,  $V_{CC1} = 4.5\text{V} \sim 5.5\text{V}$ ,  $V_{CC2} = 10\text{V} \sim 24\text{V}$ ,  $V_{EE2} = -12\text{V} \sim 0\text{V}$ )

Protection functions						
VCC1 UVLO OFF Voltage	$V_{UVLO1H}$	3.35	3.50	3.65	V	
VCC1 UVLO ON Voltage	$V_{UVLO1L}$	3.25	3.40	3.55	V	
VCC1 UVLO Mask Time	$t_{UVLO1MSK}$	4	10	30	$\mu\text{s}$	
VCC2 UVLO OFF Voltage	$V_{UVLO2H}$	8.95	9.55	10.15	V	
VCC2 UVLO ON Voltage	$V_{UVLO2L}$	8.45	9.05	9.65	V	
VCC2 UVLO Mask Time	$t_{UVLO2MSK}$	4	10	30	$\mu\text{s}$	
SCPIN Input Voltage	$V_{SCPIN}$	-	0.1	0.22	V	$I_{SCPIN} = 1\text{mA}$
SCP Threshold Voltage	$V_{SCDET}$	0.665	0.700	0.735	V	
SCP Detection Mask Time	$t_{SCPMASK}$	0.55	0.8	1.05	$\mu\text{s}$	
Soft Turn OFF Release Time	$t_{STO}$	30		110	$\mu\text{s}$	
OSFB Threshold Voltage H	$V_{OSFBH}$	4.5	5.0	5.5	V	Respective to GND2
OSFB Threshold Voltage L	$V_{OSFBL}$	4.0	4.5	5.0	V	Respective to GND2
OSFB Output Low Voltage	$V_{OSFBOL}$	-	0.18	0.40	V	$I_{OSFB} = 5\text{mA}$
OSFB Filter Time	$t_{OSFBON}$	1.5	2.0	2.6	$\mu\text{s}$	
FLT Output Low Voltage	$V_{FLT}$	-	0.18	0.40	V	$I_{FLT} = 5\text{mA}$
FLTRLS Threshold	$V_{FLTRLS}$	$0.64 \times V_{CC1} - 0.1$	$0.64 \times V_{CC1}$	$0.64 \times V_{CC1} + 0.1$	V	

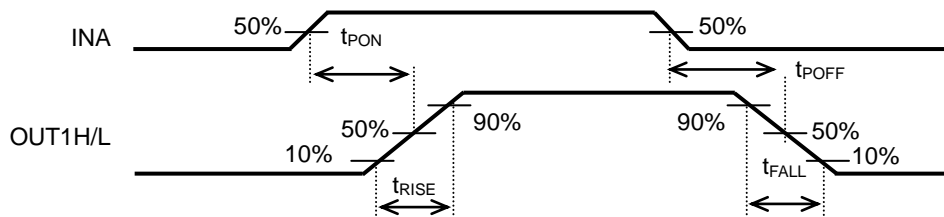

Figure 15. INA-OUT1 Timing Chart

Typical Performance Curves

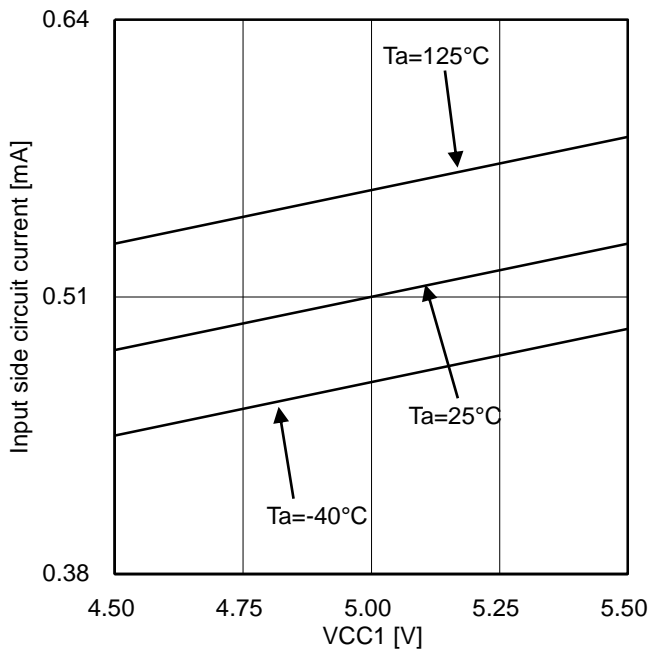

Figure 16. Input side circuit current vs. VCC1 (OUT1=L)

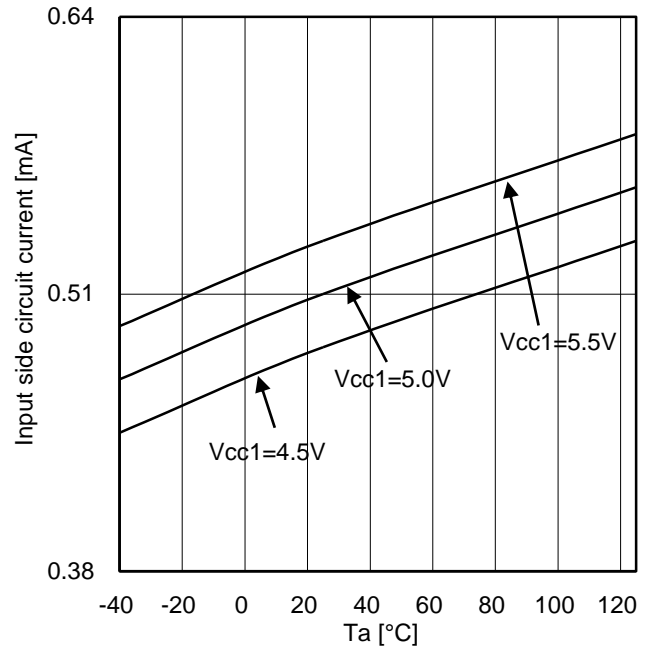

Figure 17. Input side circuit current vs. Temperature (OUT1=L)

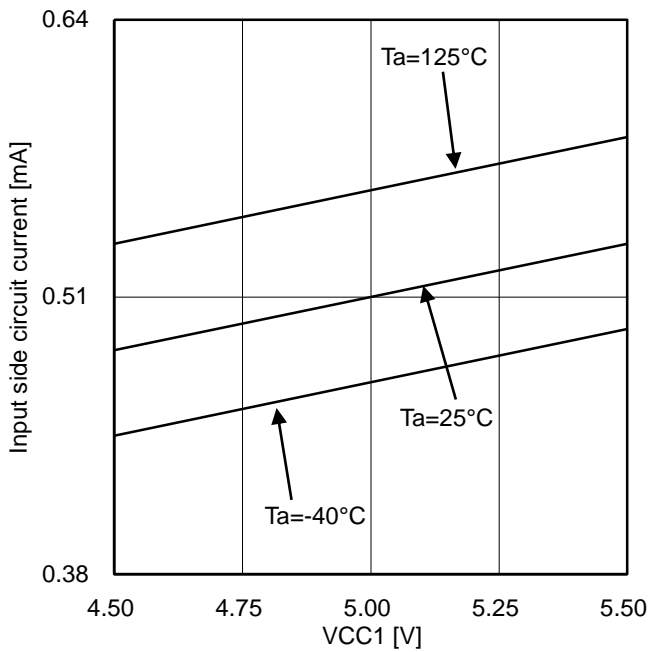

Figure 18. Input side circuit current vs. VCC1 (OUT1=H)

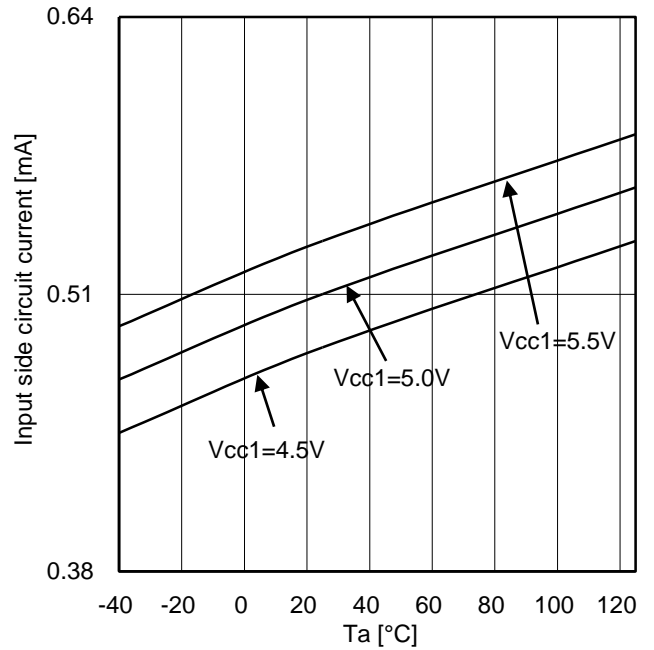

Figure 19. Input side circuit current vs. Temperature (OUT1=H)

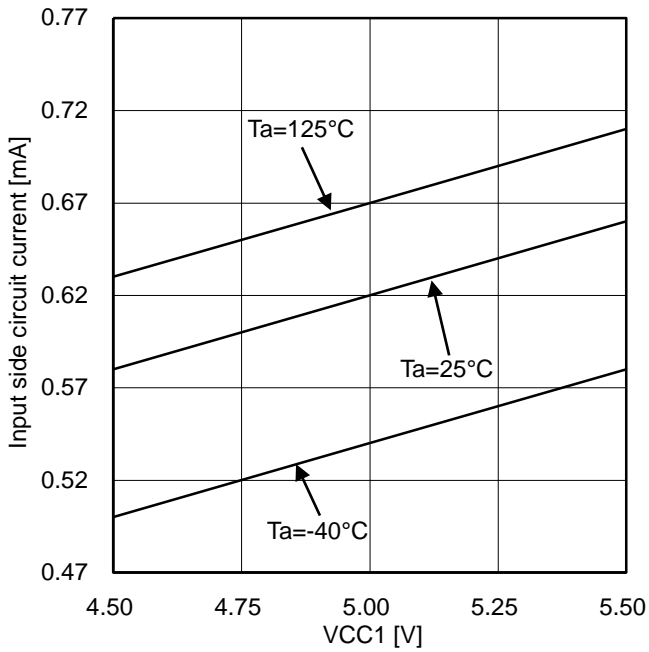

Figure 20. Input side circuit current vs. VCC1 (INA=10 kHz, Duty=50%)

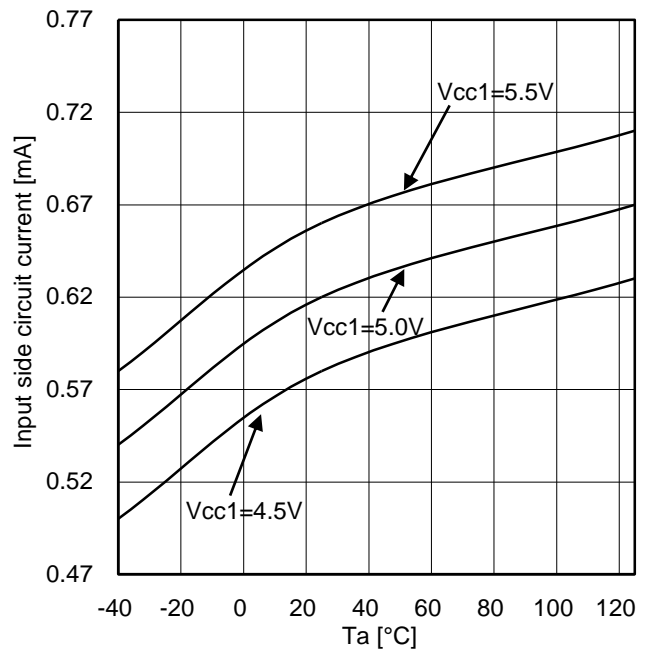

Figure 21. Input side circuit current vs. Temperature (INA=10 kHz, Duty=50%)

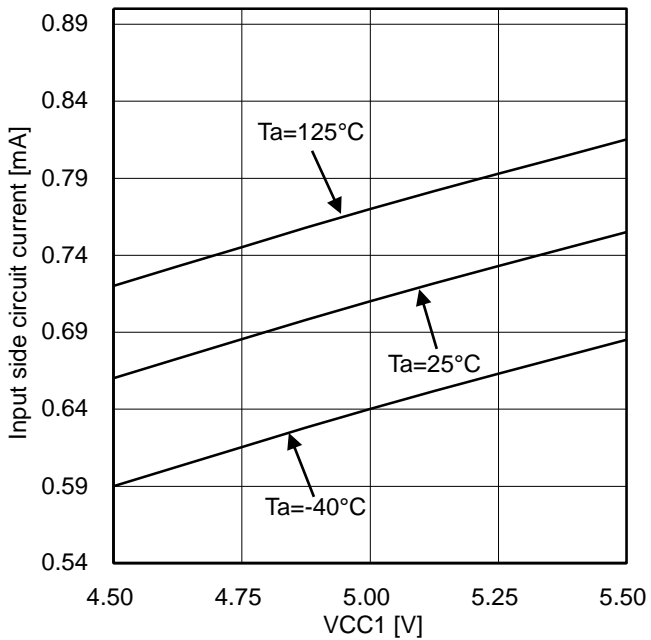

Figure 22. Input side circuit current vs. VCC1 (INA=20 kHz, Duty=50%)

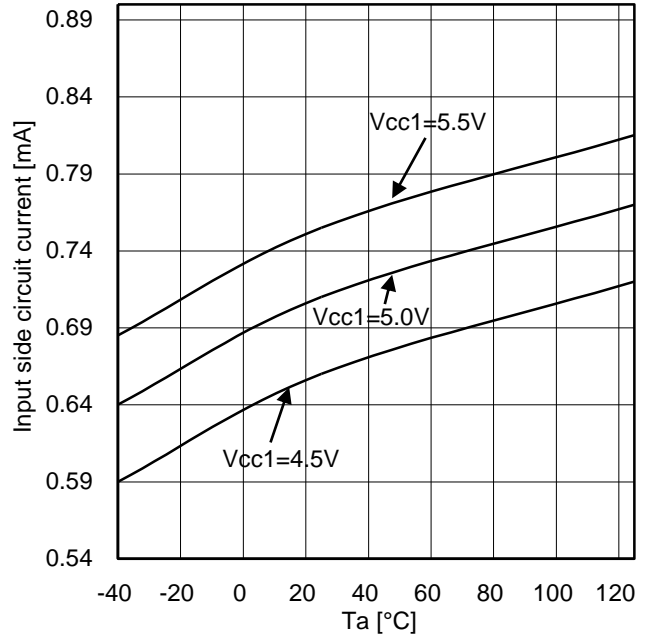

Figure 23. Input side circuit current vs. Temperature (INA=20 kHz, Duty=50%)

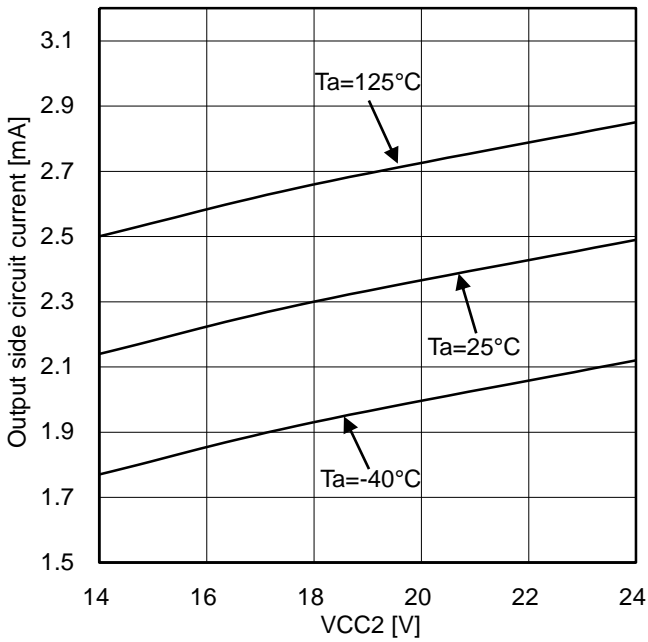

Figure 24. Output side circuit current vs. VCC2 (OUT1=L)

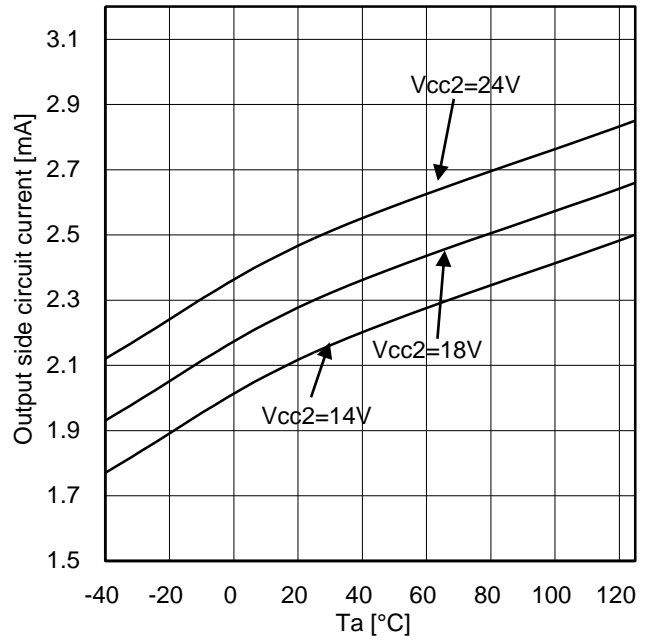

Figure 25. Output side circuit current vs. Temperature (OUT1=L)

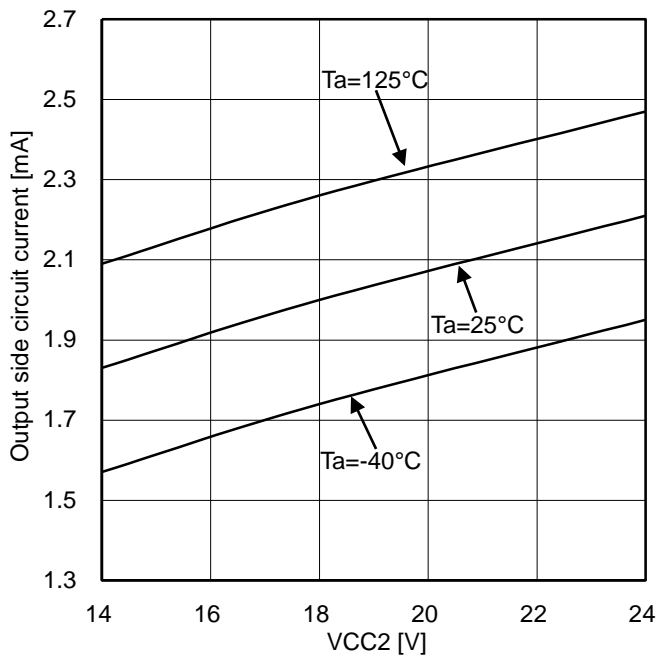

Figure 26. Output side circuit current vs. VCC2 (OUT1=H)

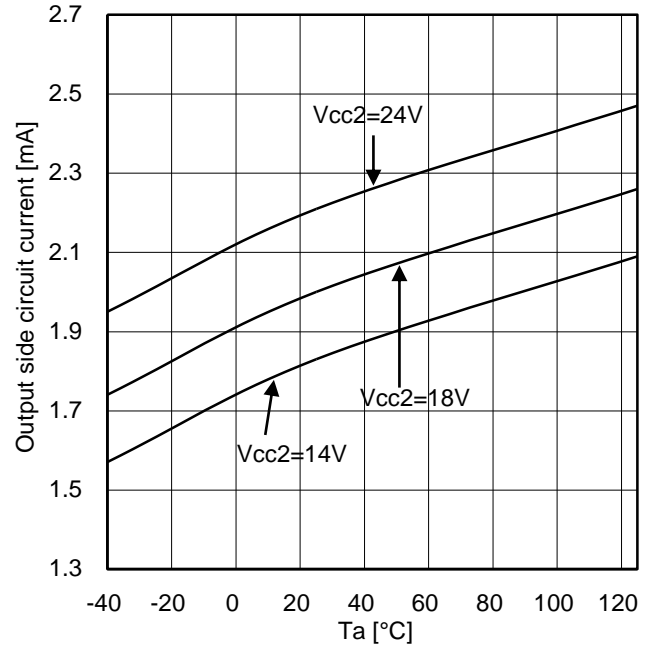

Figure 27. Output side circuit current vs. Temperature (OUT1=H)



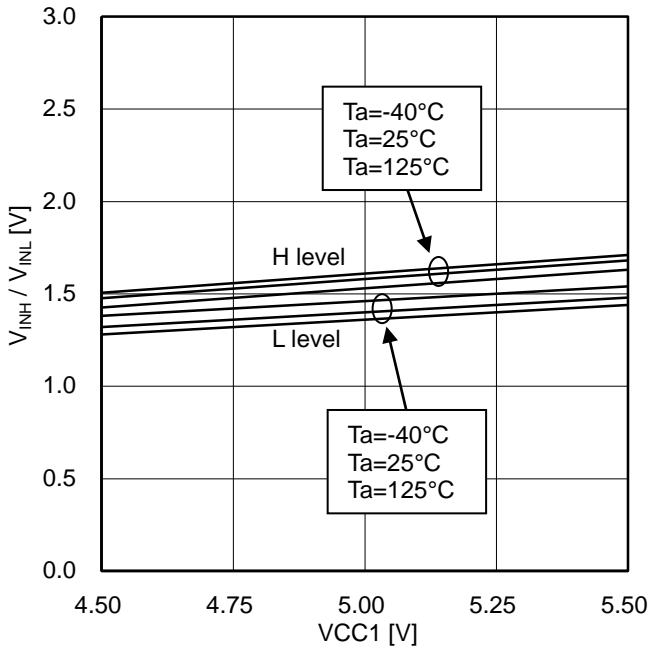

Figure 28. Logic (INA/INB/ENA) High/Low level input voltage vs. VCC1

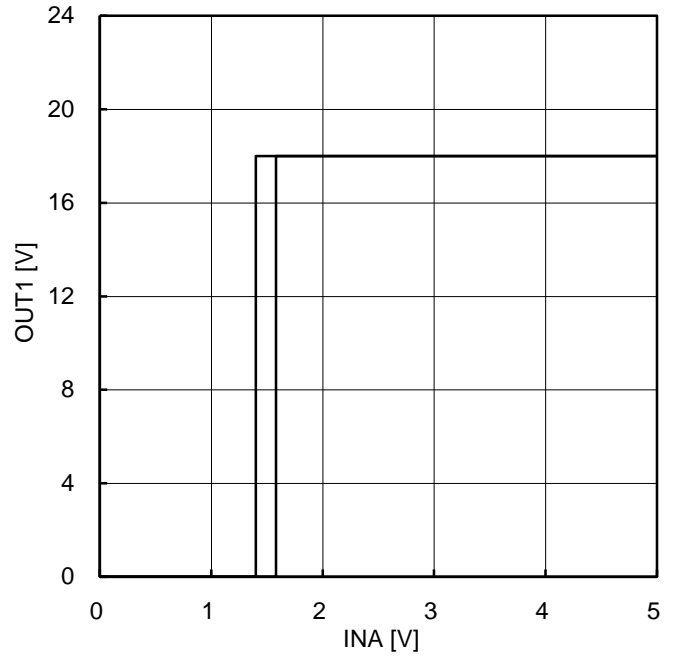

Figure 29. OUT1 vs. INA input voltage (VCC1=5V, VCC2=18V, Ta=25°C)

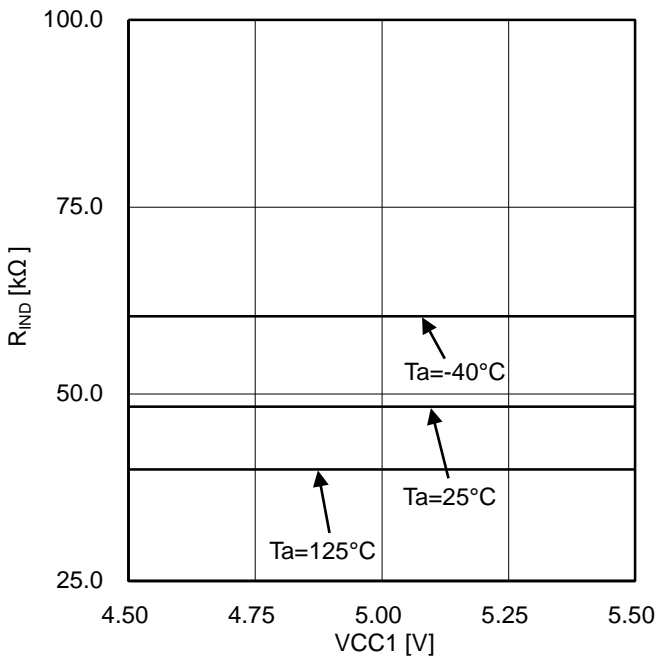

Figure 30. Logic pull-down resistance vs. VCC1

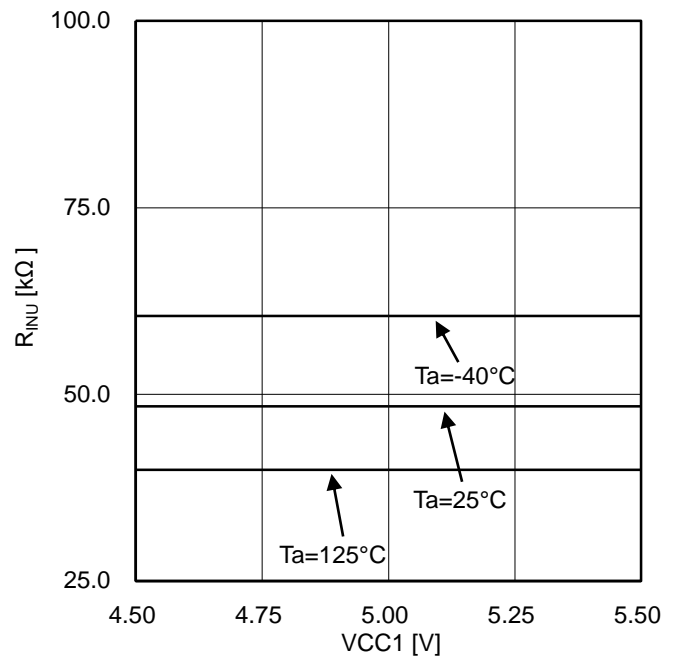

Figure 31. Logic pull-up resistance vs. VCC1

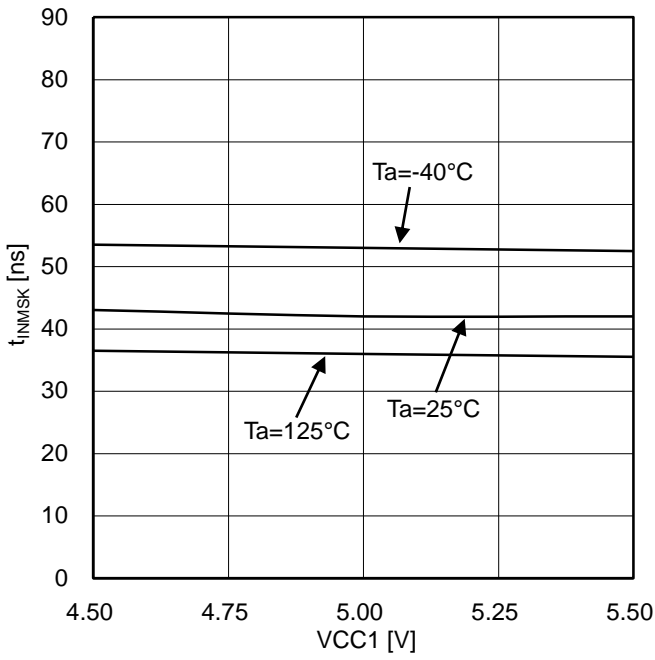

Figure 32. Logic (INA/INB) input mask time vs. VCC1 (High pulse)

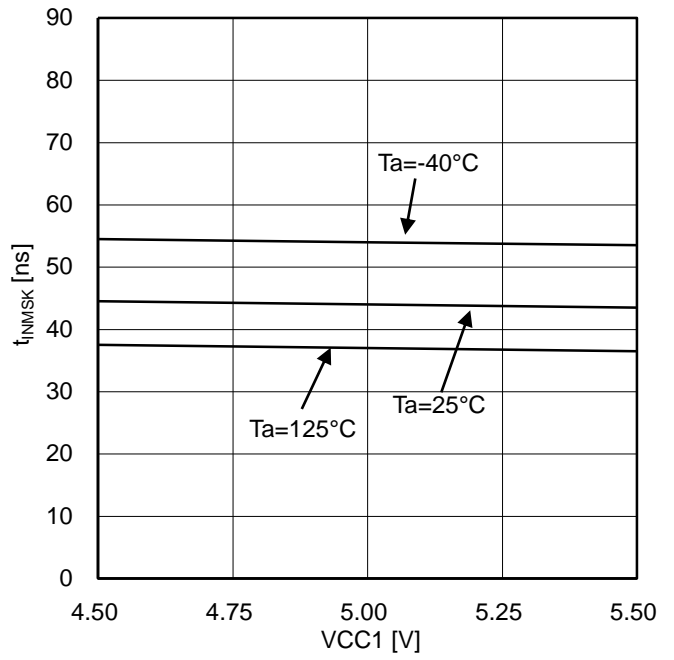

Figure 33. Logic (INA/INB) input mask time vs. VCC1 (Low pulse)

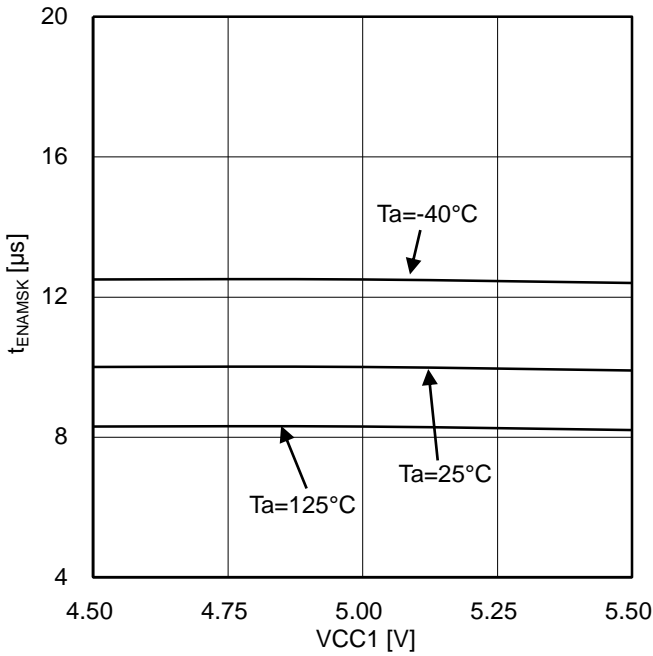

Figure 34. ENA mask time vs. VCC1

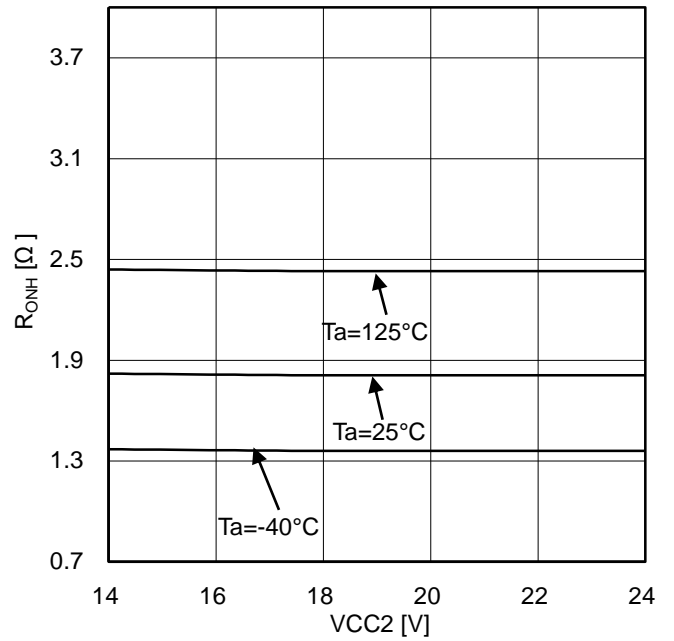

Figure 35. OUT1H ON resistance vs. VCC2

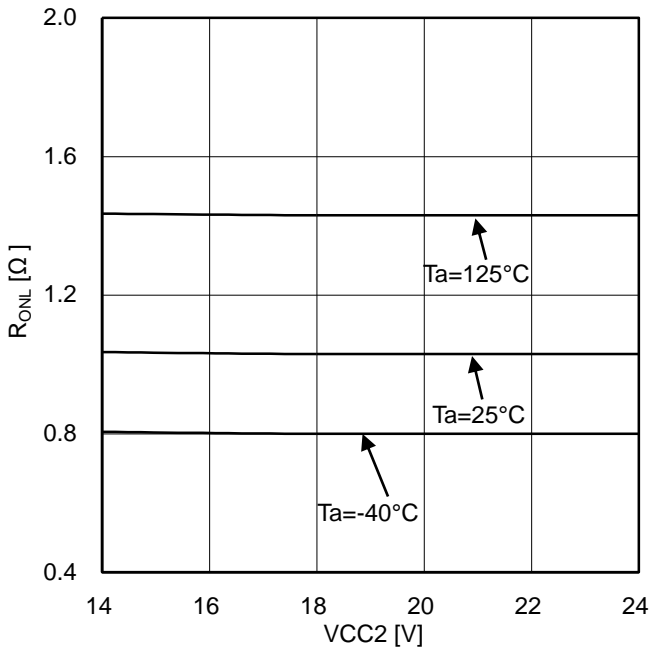

Figure 36. OUT1L ON resistance vs. VCC2

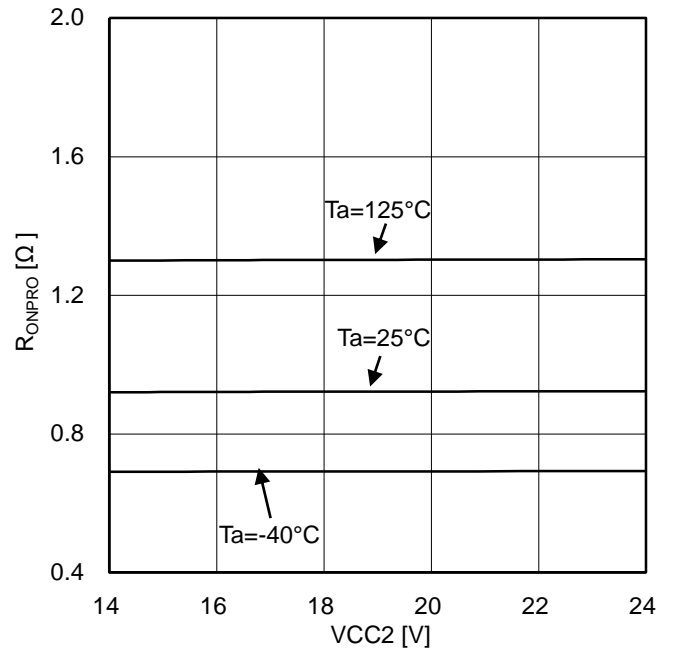

Figure 37. PROOUT ON resistance vs. VCC2

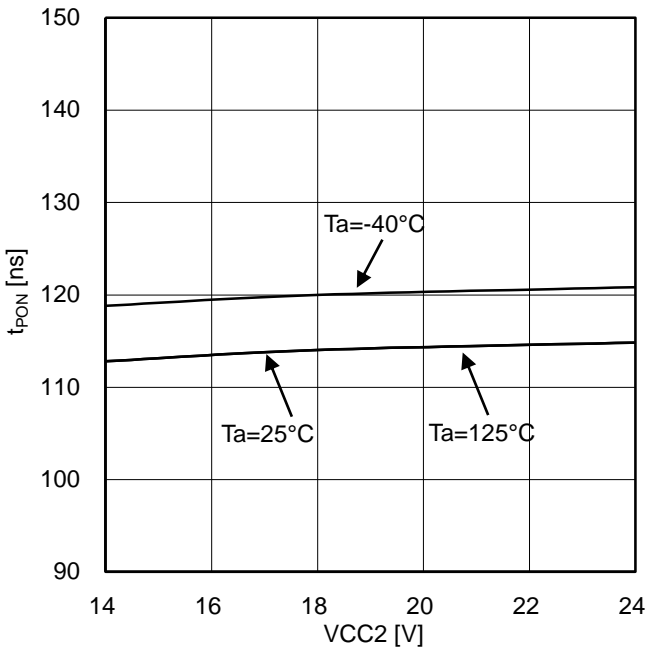

Figure 38. Turn ON time vs VCC2  
(INA=PWM, INB=L)

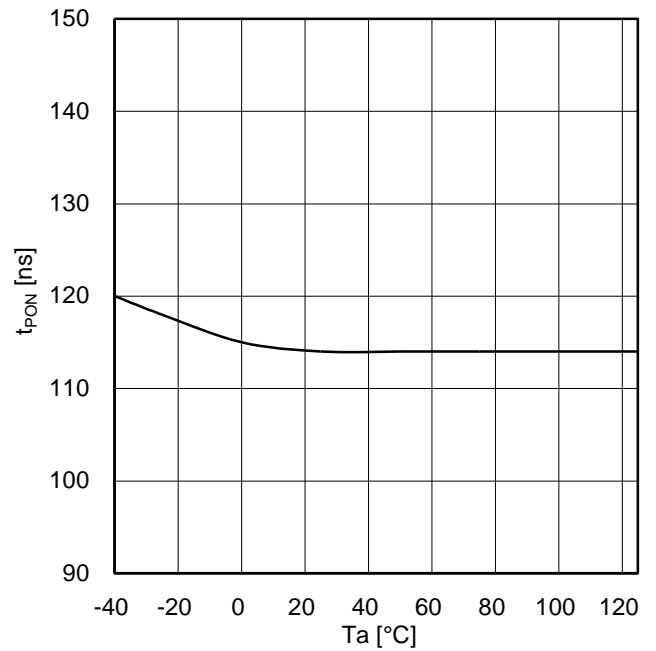

Figure 39. Turn ON time vs Temperature  
(VCC2=24V, INA=PWM, INB=L)

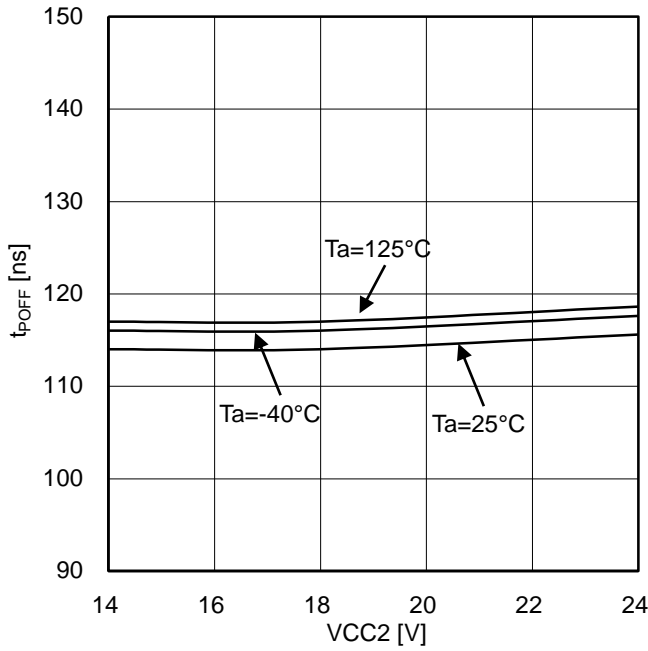

Figure 40. Turn OFF time vs. VCC2 (INA=PWM, INB=L)

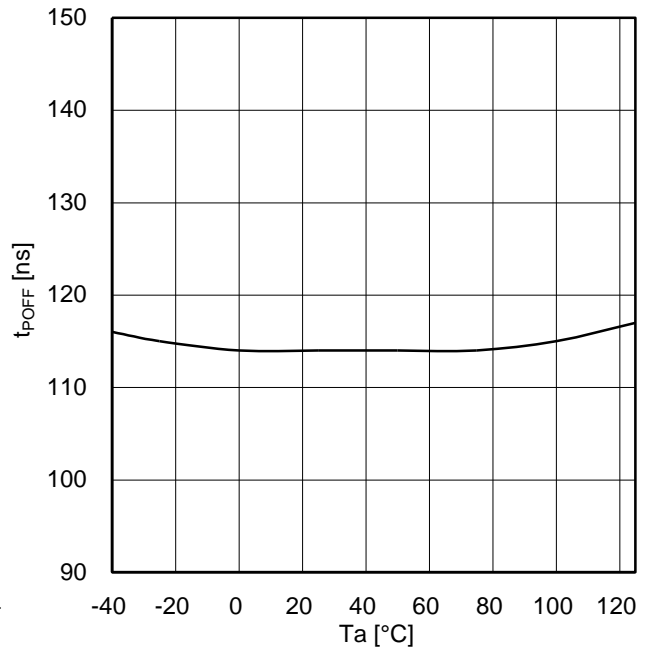

Figure 41. Turn OFF time vs. Temperature (VCC2=24V, INA=PWM, INB=L)

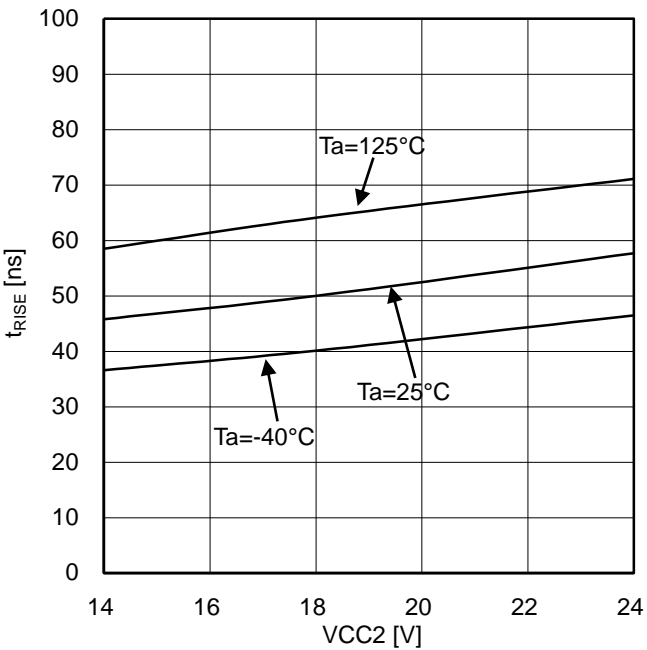

Figure 42. Rise time vs. VCC2 (10nF between OUT1-VEE2)

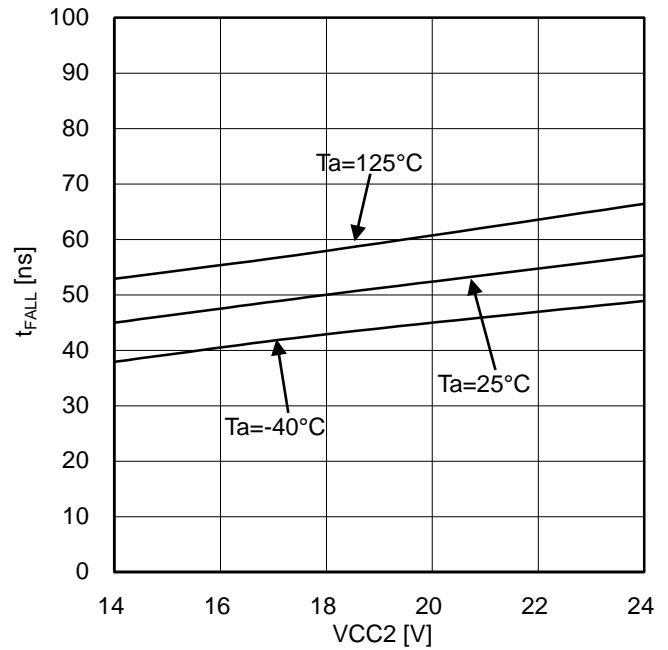

Figure 43. Fall time vs. VCC2 (10nF between OUT1-VEE2)

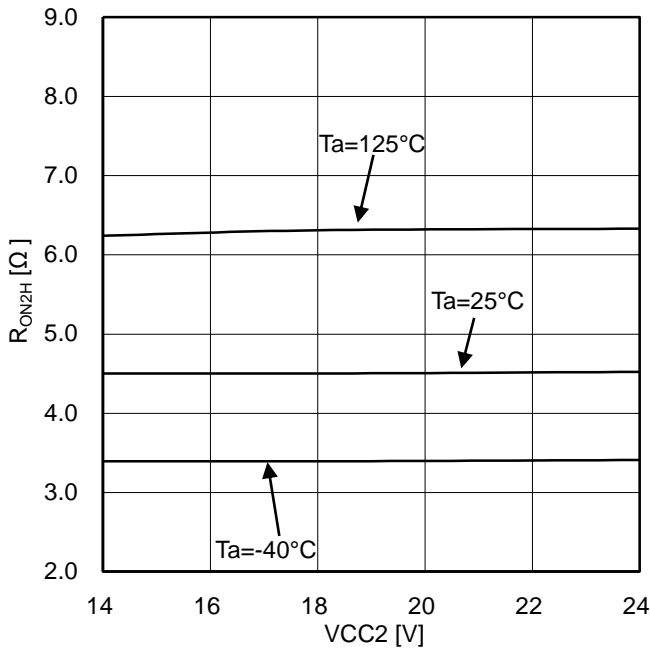

Figure 44. OUT2 ON resistance (Source) vs. VCC2

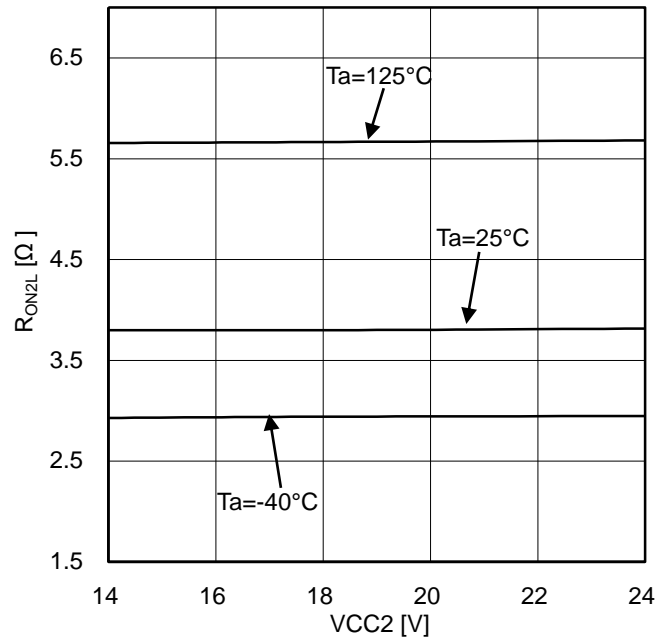

Figure 45. OUT2 ON resistance (Sink) vs. VCC2

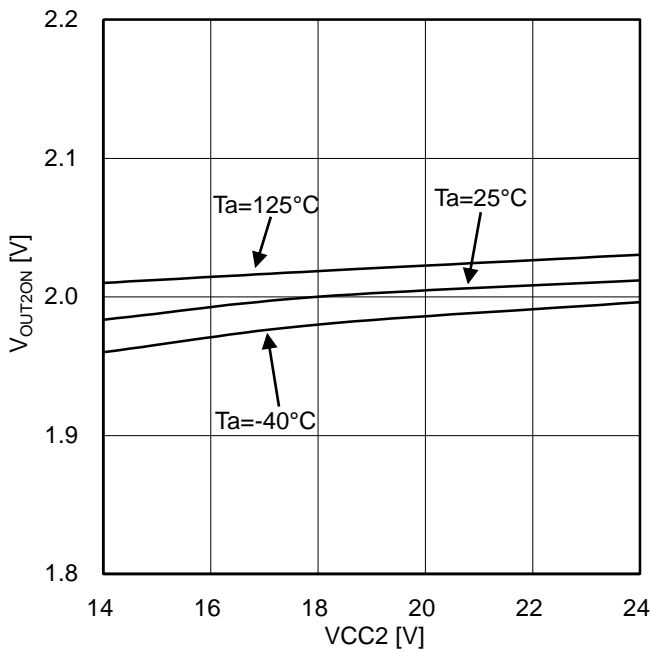

Figure 46. OUT2 ON threshold voltage vs. VCC2

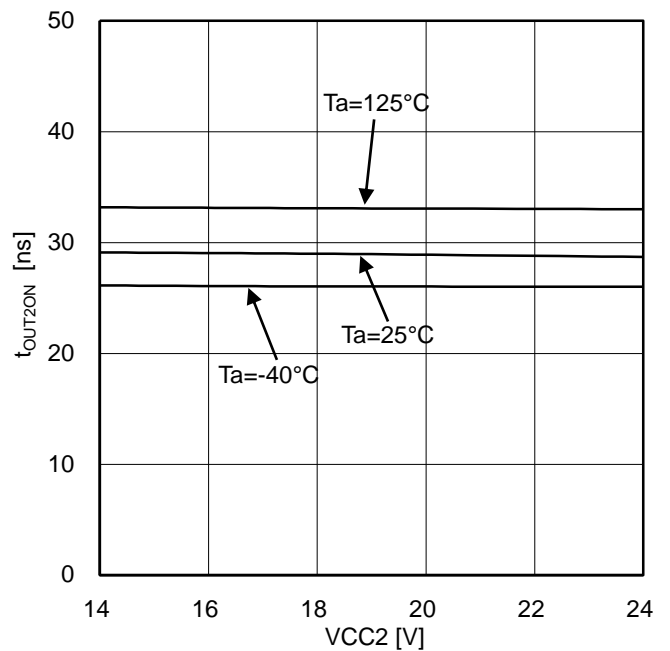

Figure 47. OUT2 output delay time vs. VCC2

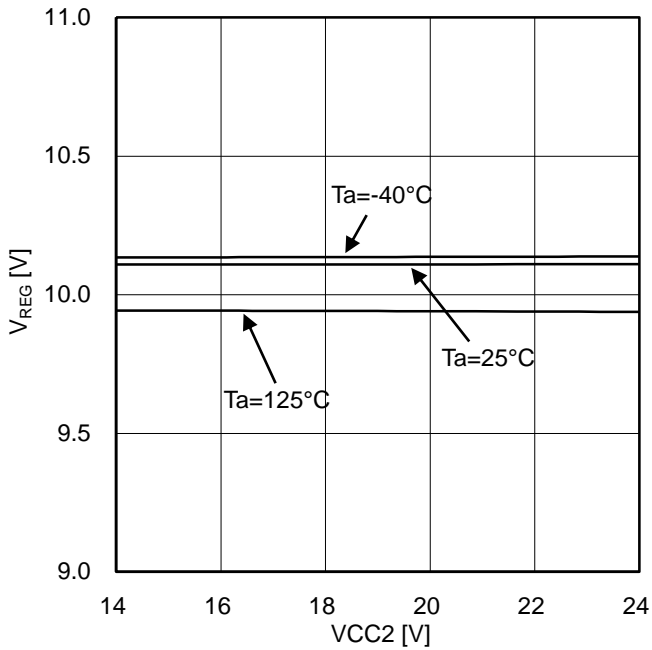

Figure 48. VREG output voltage vs. VCC2

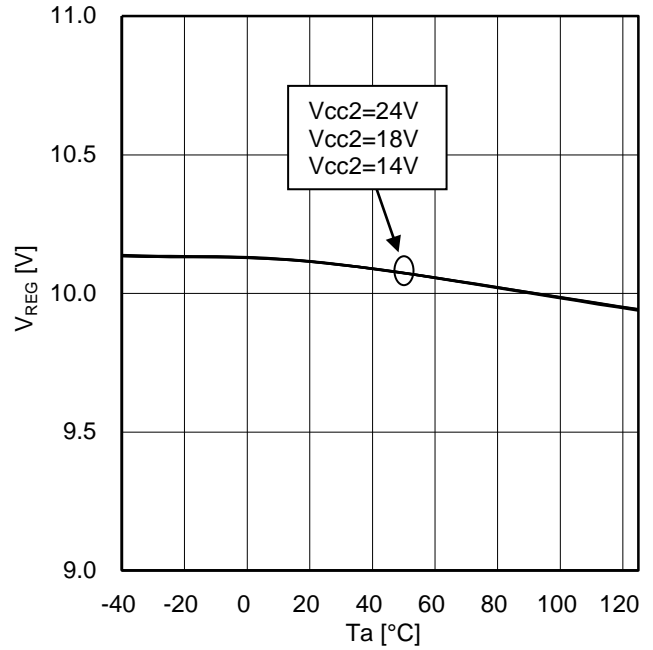

Figure 49. VREG output voltage vs. Temperature

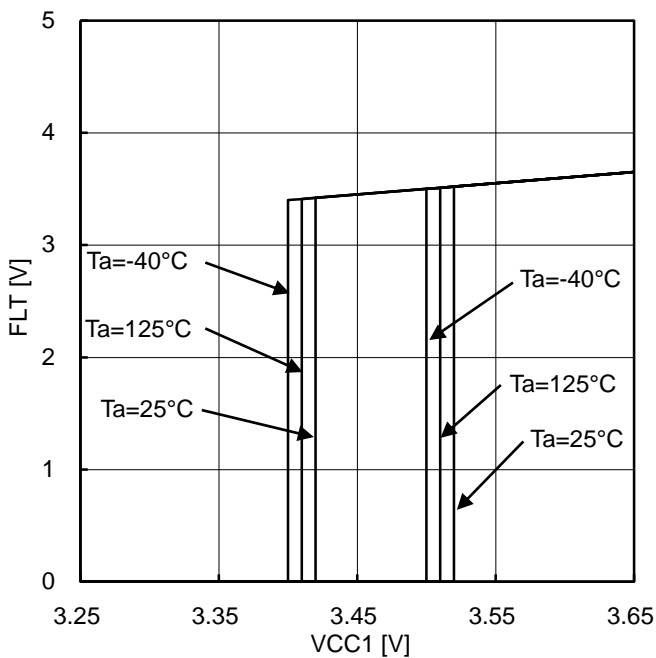

Figure 50. FLT vs. VCC1  
(VCC1 UVLO ON/OFF voltage)

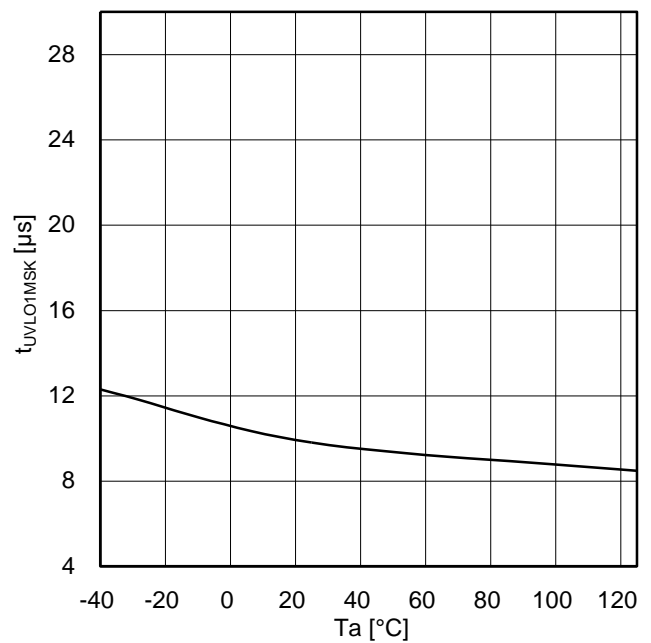

Figure 51. VCC1 UVLO mask time vs. Temperature

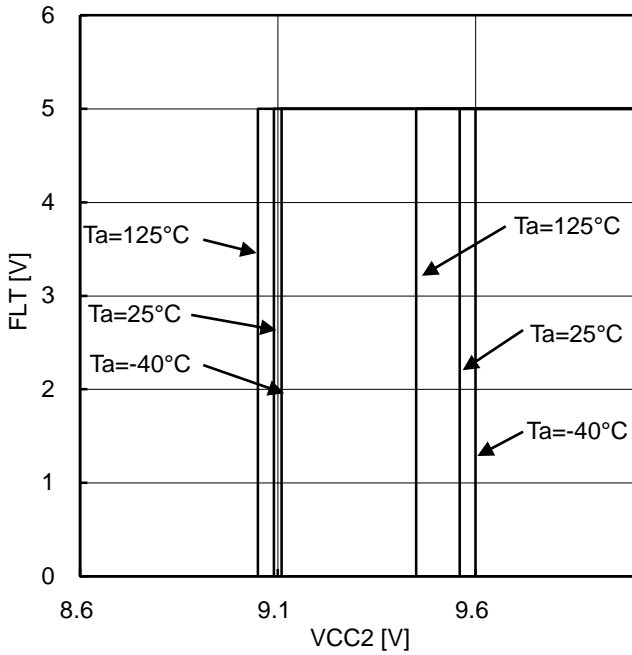

Figure 52. FLT vs. VCC2  
(VCC2 UVLO ON/OFF voltage, VCC1=5V)

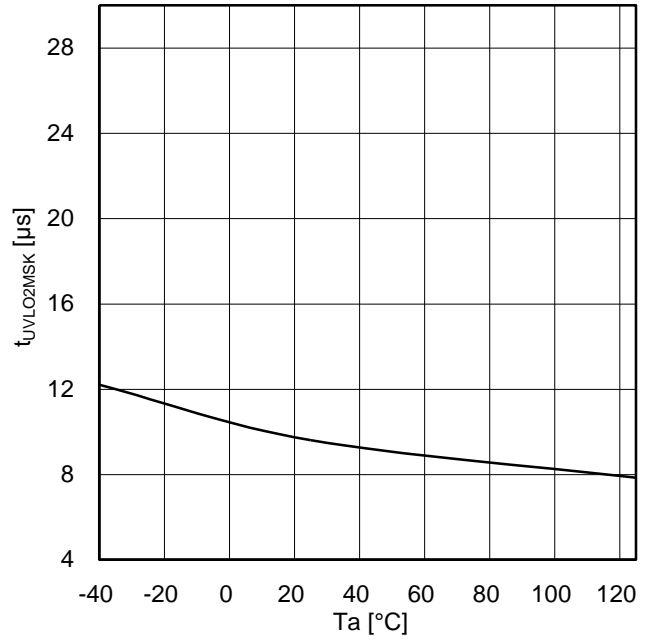

Figure 53. VCC2 UVLO mask time vs. Temperature

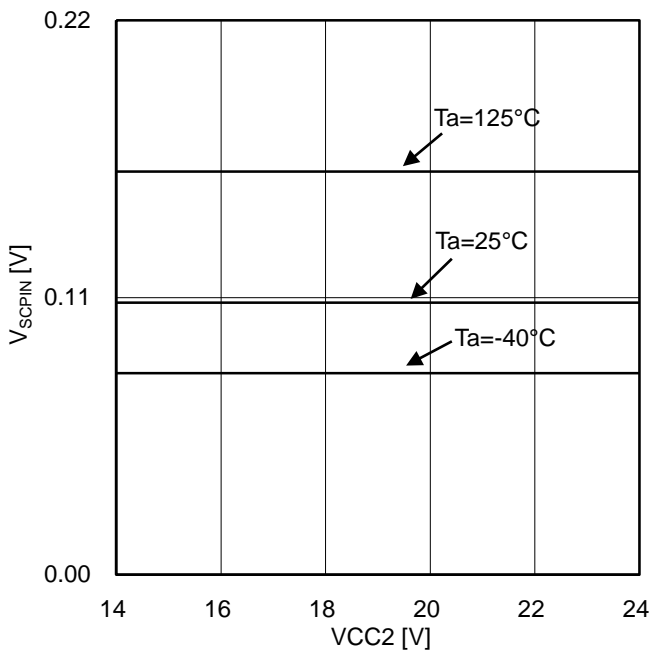

Figure 54. SCPIN Input voltage vs. VCC2  
(ISCPIN=1mA)

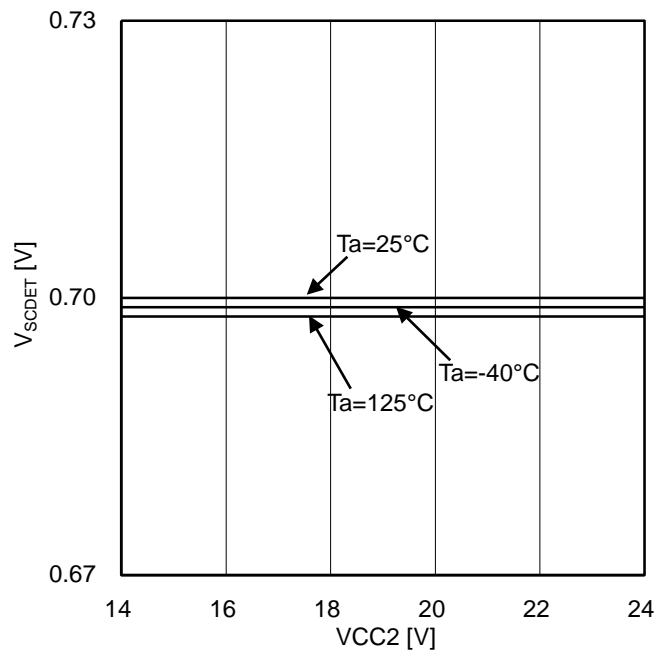

Figure 55. SCP threshold voltage vs. VCC2

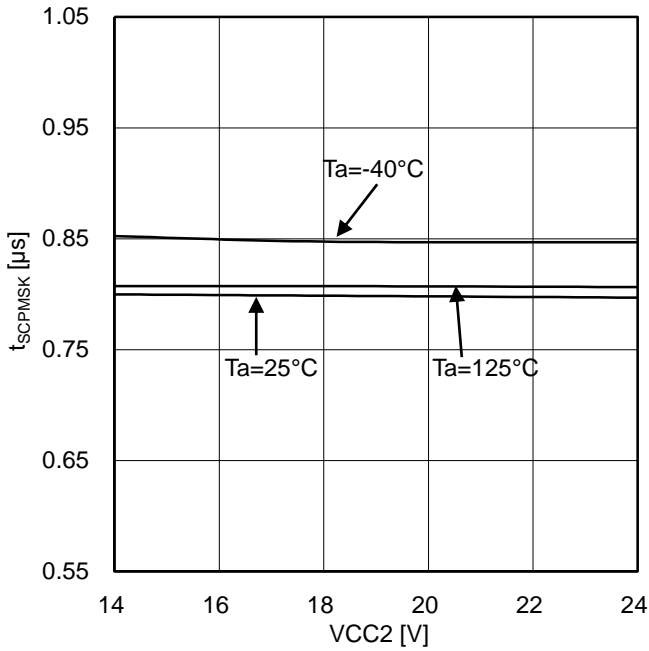

Figure 56. SCP detection mask time vs. VCC2

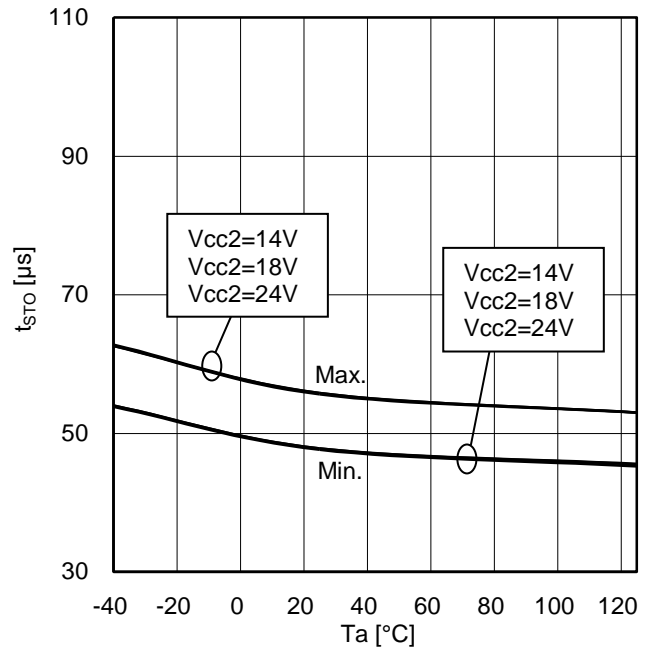

Figure 57. Soft turn OFF release time vs. Temperature

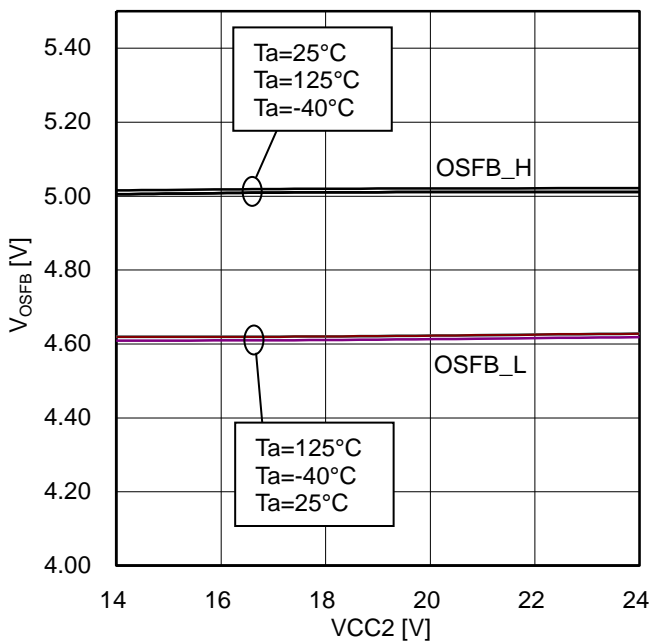

Figure 58. OSFB threshold voltage H/L vs. VCC2

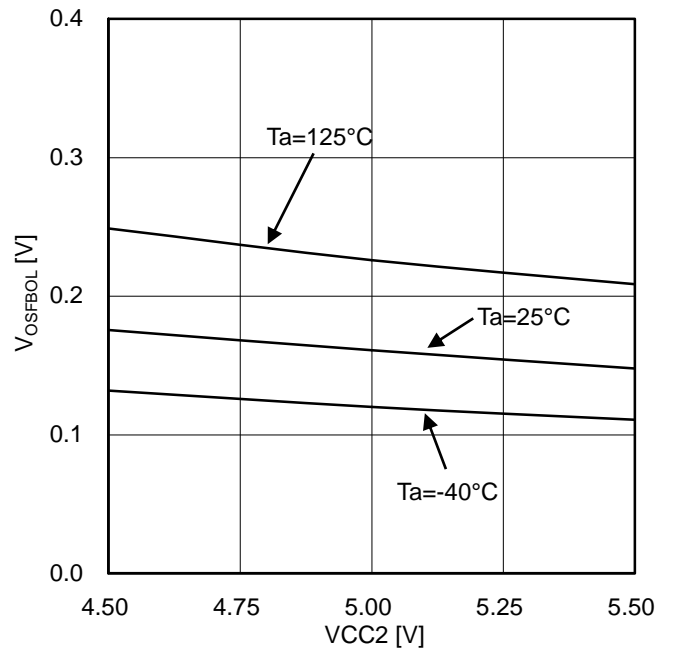

Figure 59. OSFB output low voltage vs. VCC2 (IOSFB=5mA)



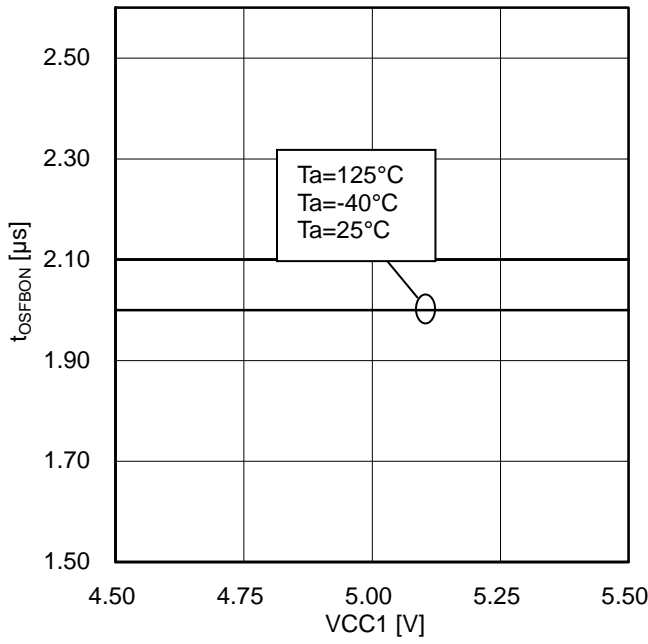

Figure 60. OSFB filter time vs. VCC1

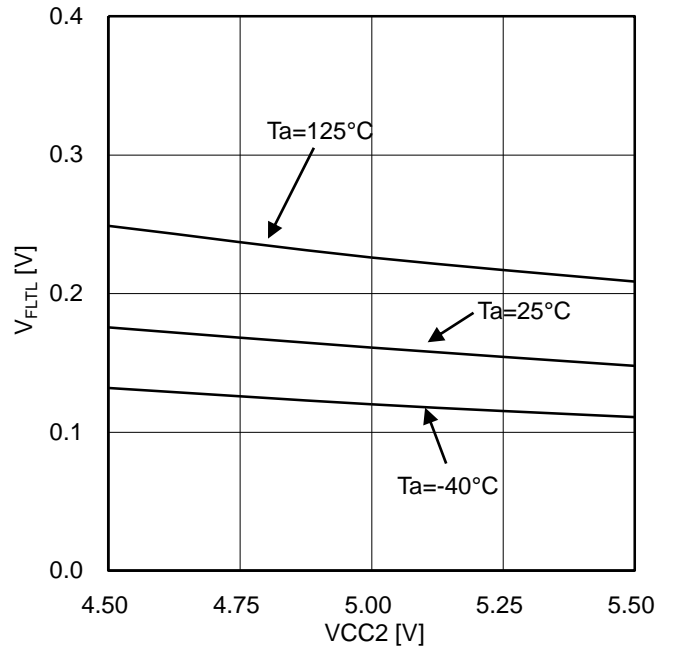

Figure 61. FLT output low voltage vs. VCC2 (IFLT=5mA)

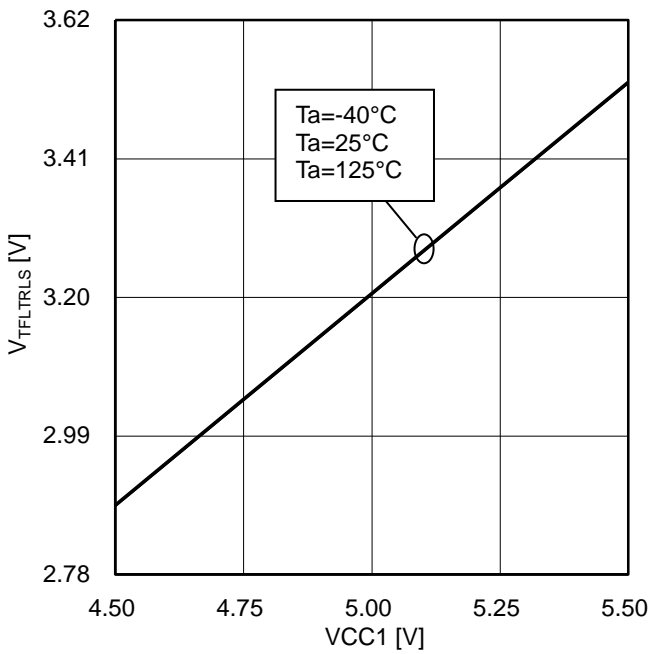

Figure 62. FLTRLS threshold vs. VCC1



Power Dissipation

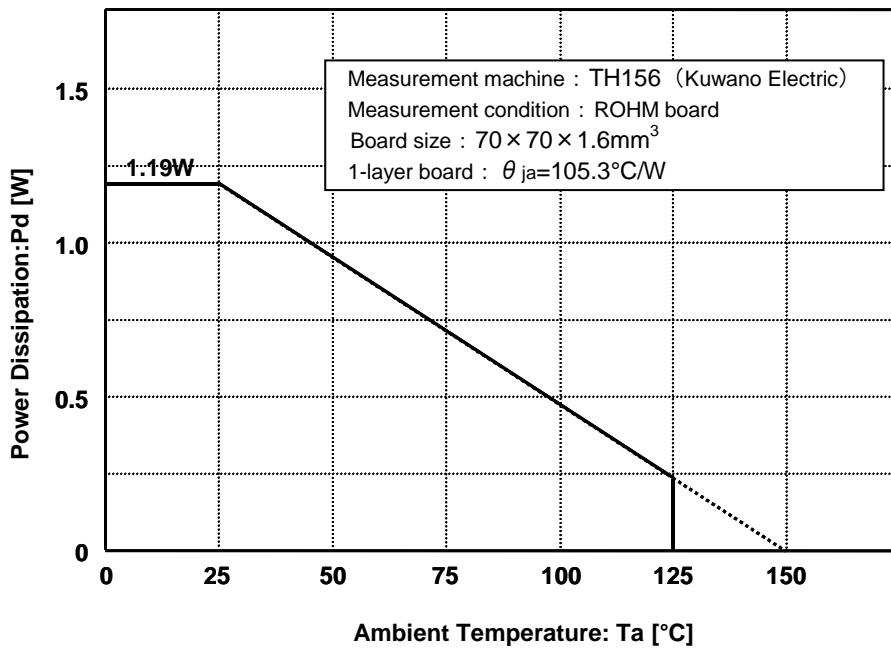

Figure 65. SSOP-B20W Derating Curve

Thermal Design

Please confirm that the IC's chip temperature  $T_j$  is not over  $150^{\circ}\text{C}$ , while considering the IC's power consumption (W), package power ( $P_d$ ) and ambient temperature ( $T_a$ ). When  $T_j=150^{\circ}\text{C}$  is exceeded, the functions as a semiconductor do not operate and some problems (ex. Abnormal operation of various parasitic elements and increasing of leak current) occur. Constant use under these circumstances leads to deterioration and eventually IC may destruct.  $T_{j\text{max}}=150^{\circ}\text{C}$  must be strictly followed under all circumstances.

I/O Equivalence Circuits

Pin No.	Name	I/O equivalence circuits
	Function	
1	SCPIN	
	Short current detection pin	
4	OUT2	
	MOSFET control pin for Miller Clamp	
5	VREG	
	Power supply pin for driving MOSFET for Miller Clamp	
7	OUT1H	
	Source side output pin	
8	OUT1L	
	Sink side output pin	
10	PROOUT	
	Soft turn-off pin	

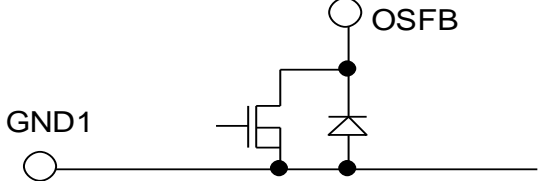
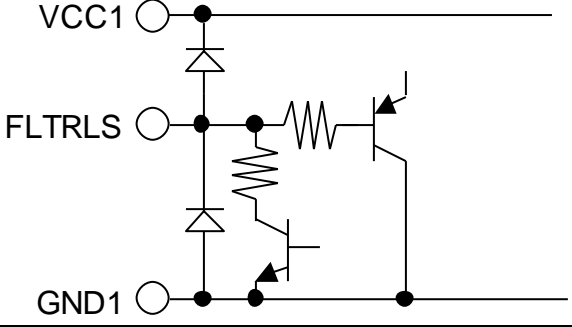
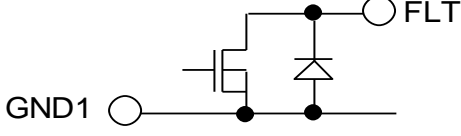
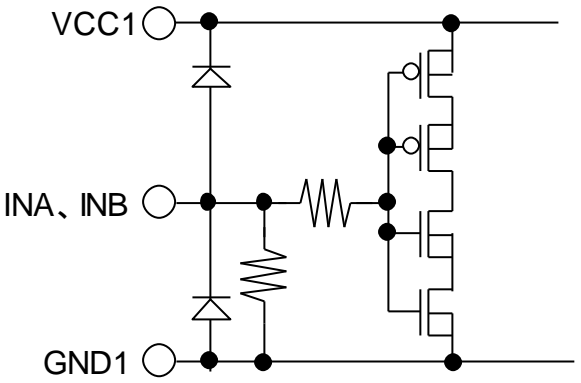
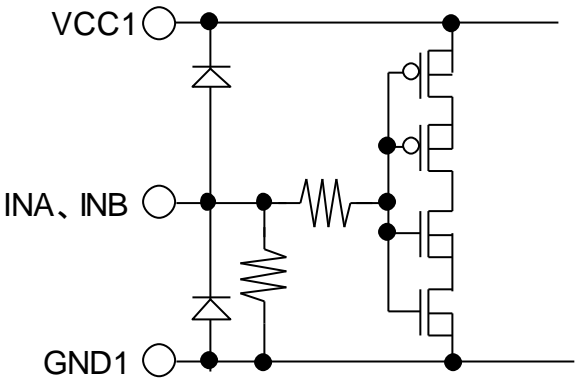
Pin No.	Name	I/O equivalence circuits
	Function	
12	OSFB	
	Output state feedback pin	
14	FLTRLS	
	Fault output holding time setting pin	
16	FLT	
	Fault output pin	
13	INB	
	Control input pin B	
17	INA	
	Control input pin A	

Pin No.	Name	I/O equivalence circuits
	Function	
18	ENA	<p>The diagram shows the internal circuit for pin 18. It features three main input nodes: VCC1 at the top, ENA in the middle, and GND1 at the bottom. A diode is connected between VCC1 and ENA, with its cathode to VCC1. Another diode is connected between ENA and GND1, with its cathode to ENA. A resistor is connected between VCC1 and ENA. A second resistor is connected between ENA and the base of a PNP transistor. The emitter of this PNP transistor is connected to VCC1, and its collector is connected to the base of an NPN transistor. The emitter of the NPN transistor is connected to GND1, and its collector is connected to the output node.</p>
	Input enabling signal input pin	
19	TEST	<p>The diagram shows the internal circuit for pin 19. It features three main input nodes: VCC1 at the top, TEST in the middle, and GND1 at the bottom. A diode is connected between VCC1 and TEST, with its cathode to VCC1. Another diode is connected between TEST and GND1, with its cathode to TEST. A resistor is connected between VCC1 and TEST. A second resistor is connected between TEST and the base of a PNP transistor. The emitter of this PNP transistor is connected to VCC1, and its collector is connected to the base of an NPN transistor. The emitter of the NPN transistor is connected to GND1, and its collector is connected to the output node.</p>
	Test mode setting pin	

## Operational Notes

### 1. Reverse Connection of Power Supply

Connecting the power supply in reverse polarity can damage the IC. Take precautions against reverse polarity when connecting the power supply, such as mounting an external diode between the power supply and the IC's power supply terminals.

### 2. Power Supply Lines

Design the PCB layout pattern to provide low impedance supply lines. Separate the ground and supply lines of the digital and analog blocks to prevent noise in the ground and supply lines of the digital block from affecting the analog block. Furthermore, connect a capacitor to ground at all power supply pins. Consider the effect of temperature and aging on the capacitance value when using electrolytic capacitors.

### 3. Ground Voltage

Ensure that no pins are at a voltage below that of the ground pin at any time, even during transient condition.

### 4. Ground Wiring Pattern

When using both small-signal and large-current ground traces, the two ground traces should be routed separately but connected to a single ground at the reference point of the application board to avoid fluctuations in the small-signal ground caused by large currents. Also ensure that the ground traces of external components do not cause variations on the ground voltage. The ground lines must be as short and thick as possible to reduce line impedance.

### 5. Thermal Consideration

Should by any chance the power dissipation rating be exceeded, the rise in temperature of the chip may result in deterioration of the properties of the chip. The absolute maximum rating of the Pd stated in this specification is when the IC is mounted on a 70mm x 70mm x 1.6mm glass epoxy board. In case of exceeding this absolute maximum rating, increase the board size and copper area to prevent exceeding the Pd rating.

### 6. Recommended Operating Conditions

These conditions represent a range within which the expected characteristics of the IC can be approximately obtained. The electrical characteristics are guaranteed under the conditions of each parameter.

### 7. Inrush Current

When power is first supplied to the IC, it is possible that the internal logic may be unstable and inrush current may flow instantaneously due to the internal powering sequence and delays, especially if the IC has more than one power supply. Therefore, give special consideration to power coupling capacitance, power wiring, width of ground wiring, and routing of connections.

### 8. Operation Under Strong Electromagnetic Field

Operating the IC in the presence of a strong electromagnetic field may cause the IC to malfunction.

### 9. Testing on Application Boards

When testing the IC on an application board, connecting a capacitor directly to a low-impedance output pin may subject the IC to stress. Always discharge capacitors completely after each process or step. The IC's power supply should always be turned off completely before connecting or removing it from the test setup during the inspection process. To prevent damage from static discharge, ground the IC during assembly and use similar precautions during transport and storage.

### 10. Inter-pin Short and Mounting Errors

Ensure that the direction and position are correct when mounting the IC on the PCB. Incorrect mounting may result in damaging the IC. Avoid nearby pins being shorted to each other especially to ground, power supply and output pin. Inter-pin shorts could be due to many reasons such as metal particles, water droplets (in very humid environment) and unintentional solder bridge deposited in between pins during assembly to name a few.

**11. Unused Input Terminals**

Input terminals of an IC are often connected to the gate of a MOS transistor. The gate has extremely high impedance and extremely low capacitance. If left unconnected, the electric field from the outside can easily charge it. The small charge acquired in this way is enough to produce a significant effect on the conduction through the transistor and cause unexpected operation of the IC. So unless otherwise specified, unused input terminals should be connected to the power supply or ground line.

**12. Regarding Input Pins of the IC**

This monolithic IC contains P+ isolation and P substrate layers between adjacent elements in order to keep them isolated. P-N junctions are formed at the intersection of the P layers with the N layers of other elements, creating a parasitic diode or transistor. For example (refer to figure below):

When GND > Pin A and GND > Pin B, the P-N junction operates as a parasitic diode.  
 When GND > Pin B, the P-N junction operates as a parasitic transistor.

Parasitic diodes inevitably occur in the structure of the IC. The operation of parasitic diodes can result in mutual interference among circuits, operational faults, or physical damage. Therefore, conditions that cause these diodes to operate, such as applying a voltage lower than the GND voltage to an input pin (and thus to the P substrate) should be avoided.

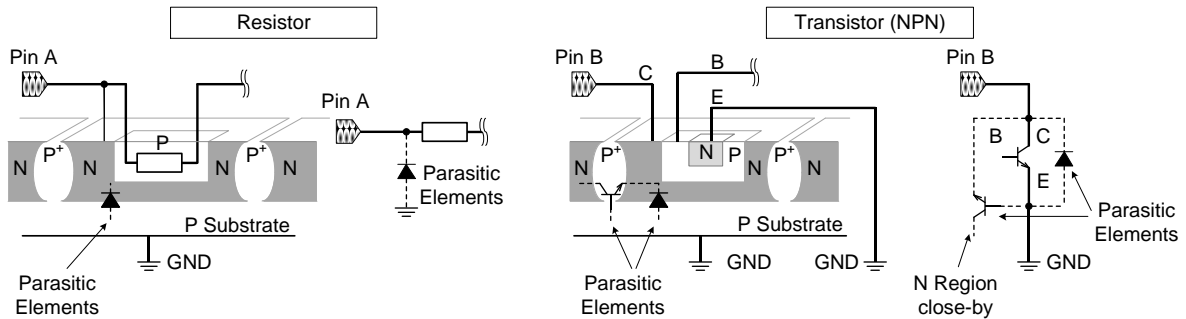

Figure 66. Example of monolithic IC structure

**13. Ceramic Capacitor**

When using a ceramic capacitor, determine the dielectric constant considering the change of capacitance with temperature and the decrease in nominal capacitance due to DC bias and others.



Ordering Information

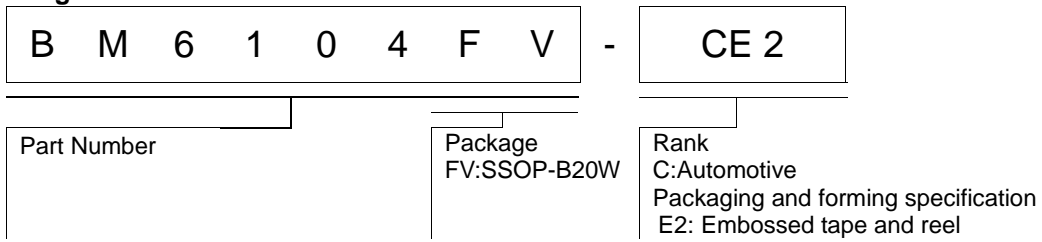

Marking Diagram

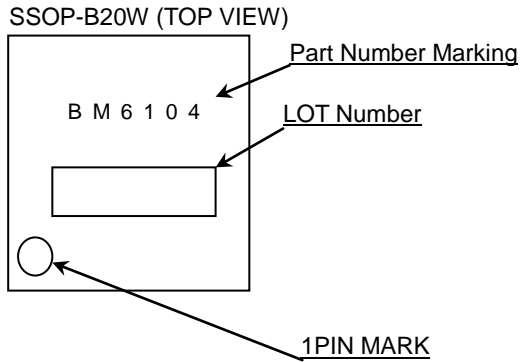

Physical Dimension, Tape and Reel Information

<b>Package Name</b>	<b>SSOP-B20W</b>
---------------------	------------------

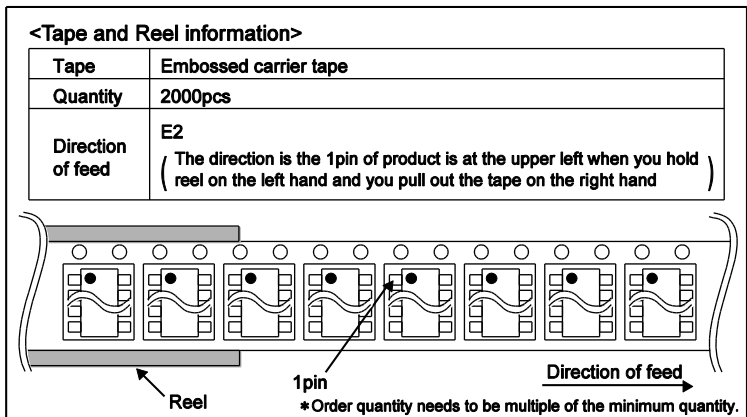
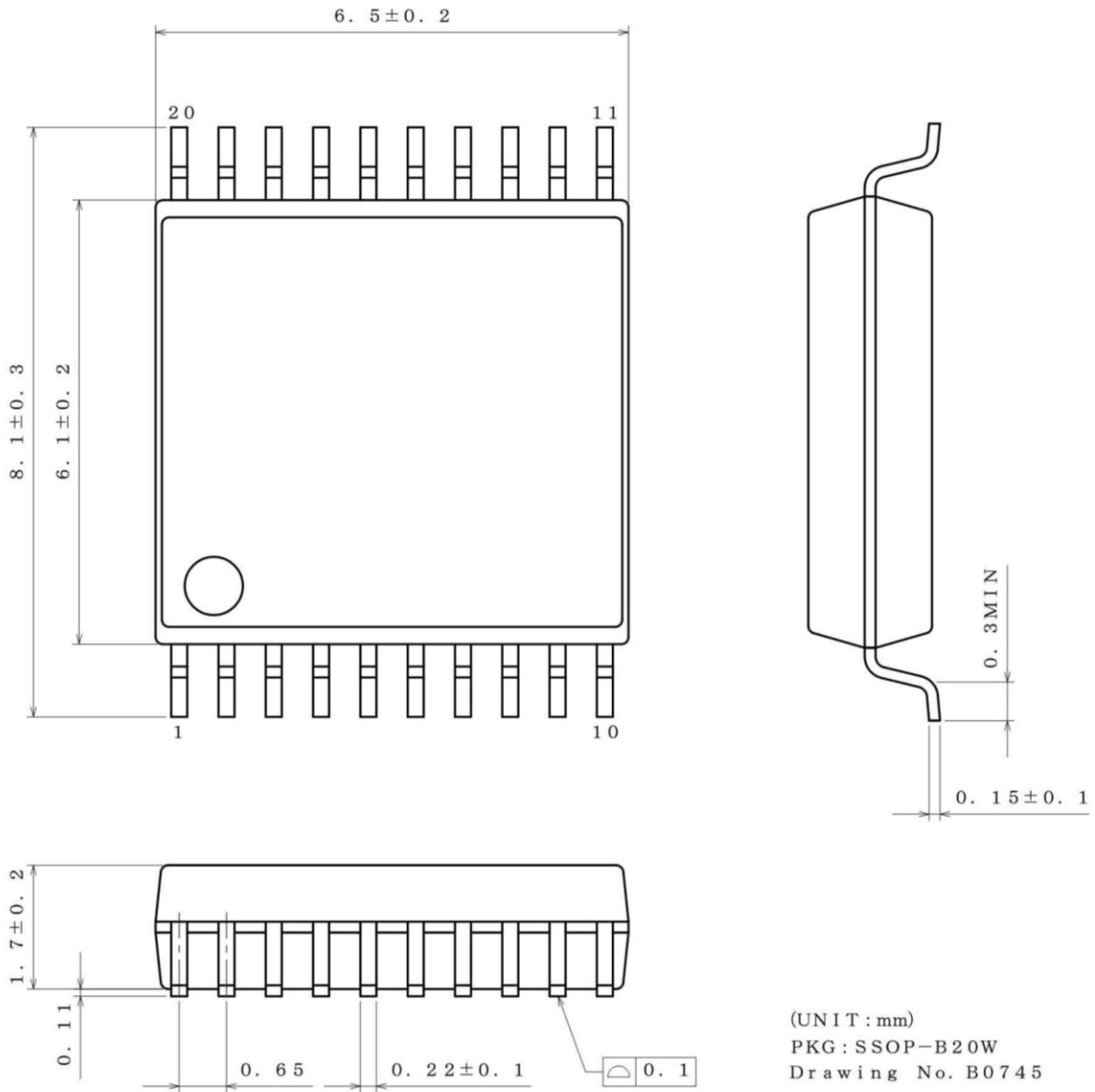

**Revision History**

<b>Date</b>	<b>Revision</b>	<b>Changes</b>
06.Nov.2013	001	New Release
23.Jan.2014	002	Page 13 : Change Electrical Characteristics ' VCC2 UVLO OFF Voltage ' Page 13 : Change Electrical Characteristics ' VCC2 UVLO ON Voltage ' Page 26 : Change Selection of Components Externally Connected
20.May.2015	003	P.1 Features Adding item (UL1577 Recognized) P.4 Description of Pins Adding TEST pin P.7 Description of functions Correcting mistake of Figure 10

# Notice

## Precaution on using ROHM Products

1. If you intend to use our Products in devices requiring extremely high reliability (such as medical equipment <sup>(Note 1)</sup>, aircraft/spacecraft, nuclear power controllers, etc.) and whose malfunction or failure may cause loss of human life, bodily injury or serious damage to property ("Specific Applications"), please consult with the ROHM sales representative in advance. Unless otherwise agreed in writing by ROHM in advance, ROHM shall not be in any way responsible or liable for any damages, expenses or losses incurred by you or third parties arising from the use of any ROHM's Products for Specific Applications.

(Note1) Medical Equipment Classification of the Specific Applications

JAPAN	USA	EU	CHINA
CLASS III	CLASS III	CLASS II b	CLASS III
CLASS IV		CLASS III	

2. ROHM designs and manufactures its Products subject to strict quality control system. However, semiconductor products can fail or malfunction at a certain rate. Please be sure to implement, at your own responsibilities, adequate safety measures including but not limited to fail-safe design against the physical injury, damage to any property, which a failure or malfunction of our Products may cause. The following are examples of safety measures:
  - [a] Installation of protection circuits or other protective devices to improve system safety
  - [b] Installation of redundant circuits to reduce the impact of single or multiple circuit failure
3. Our Products are not designed under any special or extraordinary environments or conditions, as exemplified below. Accordingly, ROHM shall not be in any way responsible or liable for any damages, expenses or losses arising from the use of any ROHM's Products under any special or extraordinary environments or conditions. If you intend to use our Products under any special or extraordinary environments or conditions (as exemplified below), your independent verification and confirmation of product performance, reliability, etc, prior to use, must be necessary:
  - [a] Use of our Products in any types of liquid, including water, oils, chemicals, and organic solvents
  - [b] Use of our Products outdoors or in places where the Products are exposed to direct sunlight or dust
  - [c] Use of our Products in places where the Products are exposed to sea wind or corrosive gases, including Cl<sub>2</sub>, H<sub>2</sub>S, NH<sub>3</sub>, SO<sub>2</sub>, and NO<sub>2</sub>
  - [d] Use of our Products in places where the Products are exposed to static electricity or electromagnetic waves
  - [e] Use of our Products in proximity to heat-producing components, plastic cords, or other flammable items
  - [f] Sealing or coating our Products with resin or other coating materials
  - [g] Use of our Products without cleaning residue of flux (even if you use no-clean type fluxes, cleaning residue of flux is recommended); or Washing our Products by using water or water-soluble cleaning agents for cleaning residue after soldering
  - [h] Use of the Products in places subject to dew condensation
4. The Products are not subject to radiation-proof design.
5. Please verify and confirm characteristics of the final or mounted products in using the Products.
6. In particular, if a transient load (a large amount of load applied in a short period of time, such as pulse. is applied, confirmation of performance characteristics after on-board mounting is strongly recommended. Avoid applying power exceeding normal rated power; exceeding the power rating under steady-state loading condition may negatively affect product performance and reliability.
7. De-rate Power Dissipation (Pd) depending on Ambient temperature (Ta). When used in sealed area, confirm the actual ambient temperature.
8. Confirm that operation temperature is within the specified range described in the product specification.
9. ROHM shall not be in any way responsible or liable for failure induced under deviant condition from what is defined in this document.

## Precaution for Mounting / Circuit board design

1. When a highly active halogenous (chlorine, bromine, etc.) flux is used, the residue of flux may negatively affect product performance and reliability.
2. In principle, the reflow soldering method must be used on a surface-mount products, the flow soldering method must be used on a through hole mount products. If the flow soldering method is preferred on a surface-mount products, please consult with the ROHM representative in advance.

For details, please refer to ROHM Mounting specification

**Precautions Regarding Application Examples and External Circuits**

1. If change is made to the constant of an external circuit, please allow a sufficient margin considering variations of the characteristics of the Products and external components, including transient characteristics, as well as static characteristics.
2. You agree that application notes, reference designs, and associated data and information contained in this document are presented only as guidance for Products use. Therefore, in case you use such information, you are solely responsible for it and you must exercise your own independent verification and judgment in the use of such information contained in this document. ROHM shall not be in any way responsible or liable for any damages, expenses or losses incurred by you or third parties arising from the use of such information.

**Precaution for Electrostatic**

This Product is electrostatic sensitive product, which may be damaged due to electrostatic discharge. Please take proper caution in your manufacturing process and storage so that voltage exceeding the Products maximum rating will not be applied to Products. Please take special care under dry condition (e.g. Grounding of human body / equipment / solder iron, isolation from charged objects, setting of Ionizer, friction prevention and temperature / humidity control).

**Precaution for Storage / Transportation**

1. Product performance and soldered connections may deteriorate if the Products are stored in the places where:
  - [a] the Products are exposed to sea winds or corrosive gases, including Cl<sub>2</sub>, H<sub>2</sub>S, NH<sub>3</sub>, SO<sub>2</sub>, and NO<sub>2</sub>
  - [b] the temperature or humidity exceeds those recommended by ROHM
  - [c] the Products are exposed to direct sunshine or condensation
  - [d] the Products are exposed to high Electrostatic
2. Even under ROHM recommended storage condition, solderability of products out of recommended storage time period may be degraded. It is strongly recommended to confirm solderability before using Products of which storage time is exceeding the recommended storage time period.
3. Store / transport cartons in the correct direction, which is indicated on a carton with a symbol. Otherwise bent leads may occur due to excessive stress applied when dropping of a carton.
4. Use Products within the specified time after opening a humidity barrier bag. Baking is required before using Products of which storage time is exceeding the recommended storage time period.

**Precaution for Product Label**

QR code printed on ROHM Products label is for ROHM's internal use only.

**Precaution for Disposition**

When disposing Products please dispose them properly using an authorized industry waste company.

**Precaution for Foreign Exchange and Foreign Trade act**

Since concerned goods might be fallen under listed items of export control prescribed by Foreign exchange and Foreign trade act, please consult with ROHM in case of export.

**Precaution Regarding Intellectual Property Rights**

1. All information and data including but not limited to application example contained in this document is for reference only. ROHM does not warrant that foregoing information or data will not infringe any intellectual property rights or any other rights of any third party regarding such information or data.
2. ROHM shall not have any obligations where the claims, actions or demands arising from the combination of the Products with other articles such as components, circuits, systems or external equipment (including software).
3. No license, expressly or implied, is granted hereby under any intellectual property rights or other rights of ROHM or any third parties with respect to the Products or the information contained in this document. Provided, however, that ROHM will not assert its intellectual property rights or other rights against you or your customers to the extent necessary to manufacture or sell products containing the Products, subject to the terms and conditions herein.

**Other Precaution**

1. This document may not be reprinted or reproduced, in whole or in part, without prior written consent of ROHM.
2. The Products may not be disassembled, converted, modified, reproduced or otherwise changed without prior written consent of ROHM.
3. In no event shall you use in any way whatsoever the Products and the related technical information contained in the Products or this document for any military purposes, including but not limited to, the development of mass-destruction weapons.
4. The proper names of companies or products described in this document are trademarks or registered trademarks of ROHM, its affiliated companies or third parties.

**General Precaution**

1. Before you use our Products, you are requested to carefully read this document and fully understand its contents. ROHM shall not be in any way responsible or liable for failure, malfunction or accident arising from the use of any ROHM's Products against warning, caution or note contained in this document.
2. All information contained in this document is current as of the issuing date and subject to change without any prior notice. Before purchasing or using ROHM's Products, please confirm the latest information with a ROHM sales representative.
3. The information contained in this document is provided on an "as is" basis and ROHM does not warrant that all information contained in this document is accurate and/or error-free. ROHM shall not be in any way responsible or liable for any damages, expenses or losses incurred by you or third parties resulting from inaccuracy or errors of or concerning such information.