

3400⇒3402/3405/3410

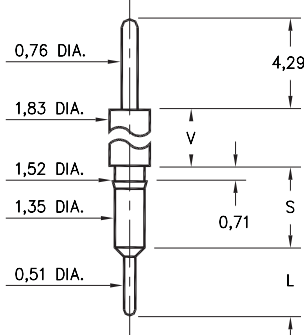

Basic Part Number	Shoulder Height V	Length S	Length L
3402-0	1,32	3,51	2,92
3401-0	2,54	3,45	2,92
3405-0	4,29	3,71	2,92
3400-0	11,71	3,68	2,92
3410-0	23,72	3,45	3,15

34XX-0-00-XX-00-00-03-0
Press-fit in 1,45 mounting hole

3411

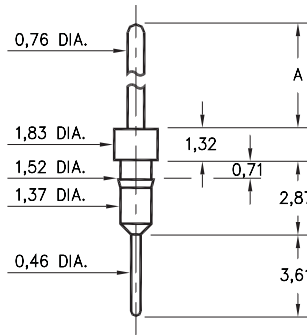

Basic Part Number	Pin Length A
3411-0	10,59
3411-1	5,51

3411-X-00-XX-00-00-03-0
Press-fit in 1,45 mounting hole

0600

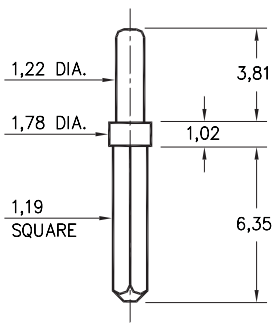

0600-0-05-XX-00-00-01-0
Solder mount in 1,32 mounting hole

0290

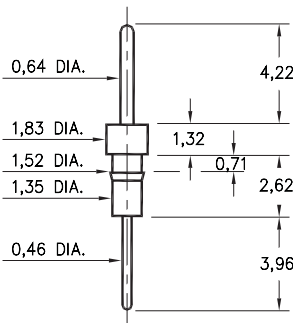

0290-0-00-XX-00-00-03-0
Press-fit in 1,45 mounting hole

7007

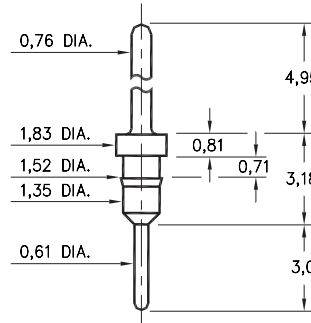

7007-0-00-XX-00-00-03-0
Press-fit in 1,45 mounting hole

5016

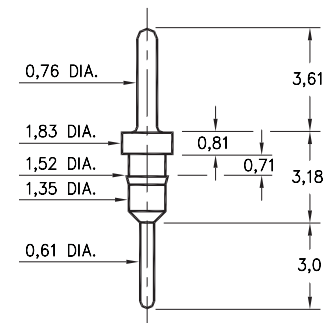

5016-0-00-XX-00-00-03-0
Press-fit in 1,45 mounting hole

5005

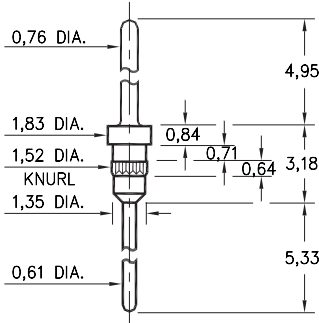

5005-0-00-XX-00-00-03-0
Press-fit in 1,45 mounting hole

5107

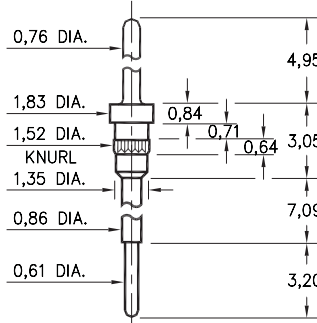

5107-0-00-XX-00-00-03-0
Press-fit in 1,45 mounting hole

8919

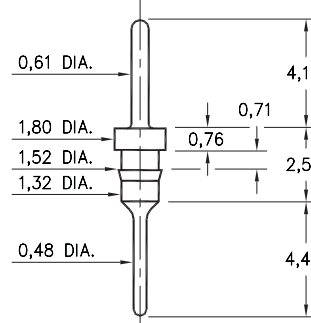

8919-0-00-XX-00-00-03-0
Press-fit in 1,45 mounting hole

3077

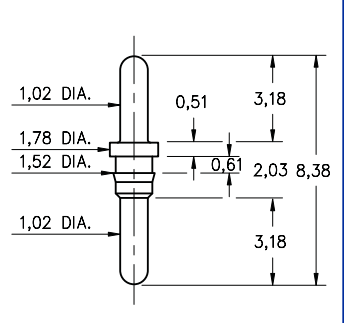

3077-0-00-XX-00-00-03-0
Press-fit in 1,45 mounting hole

SPECIFICATIONS

PIN MATERIAL:
Brass Alloy 360, 1/2 Hard
(Except where noted)

DIMENSION IN INCHES
TOLERANCES ON:
LENGTHS: ±0,13
DIAMETERS: ±0,05
ANGLES: ± 2°

ORDER CODE: XXXX - X - 0X - XX - 00 - 00 - XX - 0

BASIC PART #

SPECIFY PIN FINISH:

- 01 5,08µm TIN/LEAD OVER NICKEL
- ◇ 80 5,08µm TIN OVER NICKEL (RoHS)
- ◇ 15 0,25µm GOLD OVER NICKEL (RoHS)
- ◇ 21 0,51µm GOLD OVER NICKEL (RoHS)
- ◇ 34 1,27µm GOLD OVER NICKEL (RoHS)

