

Captive Screw Type 6 4-40 Thread

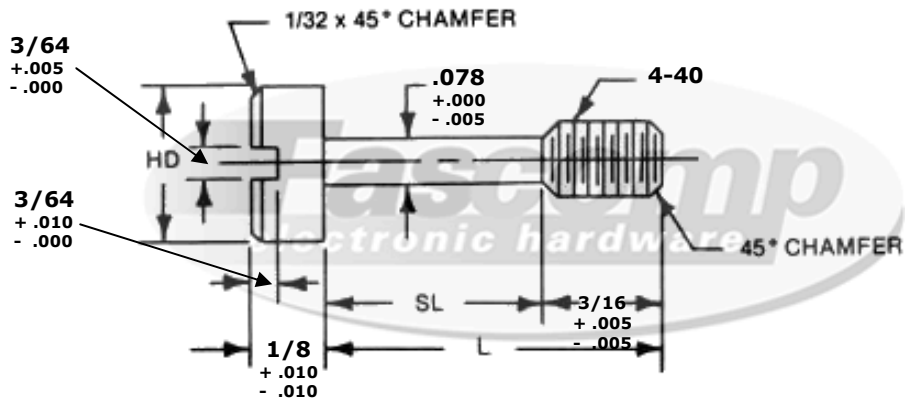

Create a part number:

Length	Material	Finish
FCXXXX	XX	XX

Captive Screws - 4-40 Thread				
FCXXXX	Length (L)	H.D. +.005 - .005	S.L. +.005 - .000	
FC7083	15/32	1/4	9/32	
FC7084	17/32	1/4	11/32	

Material		
Material Code (XX)		
B		Brass
S		Steel
SS		Stainless Steel

Compatible Finish (XX)		
B, S, SS	0	Plain
B, S	5	Nickel Plate (QQ-N-290)
B, S	12	Zinc Clear (ASTM-B-633)
B, S	16	Electro Tin (MIL-T-10727 TYPE 1)
SS	20	Passivation (MIL-F-14072D)
B, S, SS	26	Black Oxide
B, S	28	Zinc Yellow (ASTM-B-633)

Tolerances
Unless otherwise Specified
 .xxx +/- .005
 .xx +/- .010
 Angular +/- 1 Degree
 Linear +/- .005
Break all sharp edges

Source Control Drawing:
 To be produced by
 Fascomp Electronic Hardware



Fascomp Electronic Hardware
 7814 Kingspointe Pkwy
 Orlando, FL 32819
 www.fascomp.com
 Tel: (407) 226-2112
 Fax: (407) 226-3370

This document is the property of Fascomp Inc. and shall not be reproduced, distributed, or used as a basis for manufacturing without written permission from Fascomp Inc.