



**MIC4609**  
**Evaluation Board**  
**User's Guide**

---

---

**Note the following details of the code protection feature on Microchip devices:**

- Microchip products meet the specification contained in their particular Microchip Data Sheet.
- Microchip believes that its family of products is one of the most secure families of its kind on the market today, when used in the intended manner and under normal conditions.
- There are dishonest and possibly illegal methods used to breach the code protection feature. All of these methods, to our knowledge, require using the Microchip products in a manner outside the operating specifications contained in Microchip's Data Sheets. Most likely, the person doing so is engaged in theft of intellectual property.
- Microchip is willing to work with the customer who is concerned about the integrity of their code.
- Neither Microchip nor any other semiconductor manufacturer can guarantee the security of their code. Code protection does not mean that we are guaranteeing the product as "unbreakable."

Code protection is constantly evolving. We at Microchip are committed to continuously improving the code protection features of our products. Attempts to break Microchip's code protection feature may be a violation of the Digital Millennium Copyright Act. If such acts allow unauthorized access to your software or other copyrighted work, you may have a right to sue for relief under that Act.

---

Information contained in this publication regarding device applications and the like is provided only for your convenience and may be superseded by updates. It is your responsibility to ensure that your application meets with your specifications. MICROCHIP MAKES NO REPRESENTATIONS OR WARRANTIES OF ANY KIND WHETHER EXPRESS OR IMPLIED, WRITTEN OR ORAL, STATUTORY OR OTHERWISE, RELATED TO THE INFORMATION, INCLUDING BUT NOT LIMITED TO ITS CONDITION, QUALITY, PERFORMANCE, MERCHANTABILITY OR FITNESS FOR PURPOSE. Microchip disclaims all liability arising from this information and its use. Use of Microchip devices in life support and/or safety applications is entirely at the buyer's risk, and the buyer agrees to defend, indemnify and hold harmless Microchip from any and all damages, claims, suits, or expenses resulting from such use. No licenses are conveyed, implicitly or otherwise, under any Microchip intellectual property rights unless otherwise stated.

*Microchip received ISO/TS-16949:2009 certification for its worldwide headquarters, design and wafer fabrication facilities in Chandler and Tempe, Arizona; Gresham, Oregon and design centers in California and India. The Company's quality system processes and procedures are for its PIC<sup>®</sup> MCUs and dsPIC<sup>®</sup> DSCs, KEELOQ<sup>®</sup> code hopping devices, Serial EEPROMs, microperipherals, nonvolatile memory and analog products. In addition, Microchip's quality system for the design and manufacture of development systems is ISO 9001:2000 certified.*

**QUALITY MANAGEMENT SYSTEM  
CERTIFIED BY DNV  
= ISO/TS 16949 =**

**Trademarks**

The Microchip name and logo, the Microchip logo, AnyRate, dsPIC, FlashFlex, flexPWR, Heldo, JukeBlox, KeeLoq, KeeLoq logo, Klear, LANCheck, LINK MD, MediaLB, MOST, MOST logo, MPLAB, OptoLyzer, PIC, PICSTART, PIC32 logo, RightTouch, SpyNIC, SST, SST Logo, SuperFlash and UNI/O are registered trademarks of Microchip Technology Incorporated in the U.S.A. and other countries.

ClockWorks, The Embedded Control Solutions Company, ETHERSYNCH, Hyper Speed Control, HyperLight Load, IntelliMOS, mTouch, Precision Edge, and QUIET-WIRE are registered trademarks of Microchip Technology Incorporated in the U.S.A.

Analog-for-the-Digital Age, Any Capacitor, AnyIn, AnyOut, BodyCom, chipKIT, chipKIT logo, CodeGuard, dsPICDEM, dsPICDEM.net, Dynamic Average Matching, DAM, ECAN, EtherGREEN, In-Circuit Serial Programming, ICSP, Inter-Chip Connectivity, JitterBlocker, KlearNet, KlearNet logo, MiWi, motorBench, MPASM, MPF, MPLAB Certified logo, MPLIB, MPLINK, MultiTRAK, NetDetach, Omniscient Code Generation, PICDEM, PICDEM.net, PICkit, PICtail, PureSilicon, RightTouch logo, REAL ICE, Ripple Blocker, Serial Quad I/O, SQL, SuperSwitcher, SuperSwitcher II, Total Endurance, TSHARC, USBCheck, VariSense, ViewSpan, WiperLock, Wireless DNA, and ZENA are trademarks of Microchip Technology Incorporated in the U.S.A. and other countries.

SQTP is a service mark of Microchip Technology Incorporated in the U.S.A.

Silicon Storage Technology is a registered trademark of Microchip Technology Inc. in other countries.

GestIC is a registered trademarks of Microchip Technology Germany II GmbH & Co. KG, a subsidiary of Microchip Technology Inc., in other countries.

All other trademarks mentioned herein are property of their respective companies.

© 2016, Microchip Technology Incorporated, Printed in the U.S.A., All Rights Reserved.

ISBN: 978-1-5224-0437-8

---

---

**Object of Declaration: MIC4609 Evaluation Board**

EU Declaration of Conformity

Manufacturer: Microchip Technology Inc.  
2355 W. Chandler Blvd.  
Chandler, Arizona, 85224-6199  
USA

This declaration of conformity is issued by the manufacturer.

The development/evaluation tool is designed to be used for research and development in a laboratory environment. This development/evaluation tool is not a Finished Appliance, nor is it intended for incorporation into Finished Appliances that are made commercially available as single functional units to end users under EU EMC Directive 2004/108/EC and as supported by the European Commission's Guide for the EMC Directive 2004/108/EC (8<sup>th</sup> February 2010).

This development/evaluation tool complies with EU RoHS2 Directive 2011/65/EU.

This development/evaluation tool, when incorporating wireless and radio-telecom functionality, is in compliance with the essential requirement and other relevant provisions of the R&TTE Directive 1999/5/EC and the FCC rules as stated in the declaration of conformity provided in the module datasheet and the module product page available at [www.microchip.com](http://www.microchip.com).

For information regarding the exclusive, limited warranties applicable to Microchip products, please see Microchip's standard terms and conditions of sale, which are printed on our sales documentation and available at [www.microchip.com](http://www.microchip.com).

Signed for and on behalf of Microchip Technology Inc. at Chandler, Arizona, USA

  
Derek Carlson  
VP Development Tools

12-Sep-14  
Date

---

---

**NOTES:**

**Table of Contents**

<b>Preface</b> .....	<b>7</b>
Introduction.....	7
Document Layout .....	7
Conventions Used in This Guide.....	8
Recommended Reading.....	8
The Microchip Website .....	9
Customer Support .....	9
Revision History .....	9
 <b>Chapter 1. Product Overview</b>	
1.1 Introduction .....	11
1.2 MIC4609 Short Overview .....	11
1.3 What is the MIC4609 Evaluation Board? .....	11
1.4 MIC4609 Evaluation Board Kit Contents .....	11
 <b>Chapter 2. Installation and Operation</b>	
2.1 System and Configuration Requirements .....	13
2.2 Circuit Description .....	13
2.2.1 Overcurrent and Fault circuitry .....	14
2.2.2 Enable Pin (EN) .....	14
2.2.3 Input Pins (xHI/xLI) .....	14
2.2.4 Power and Motor Connections .....	14
2.2.5 Power Stage and Motor Connections .....	15
 <b>Appendix A. Schematic and Layouts</b>	
A.1 Introduction .....	17
A.2 Board – Schematic .....	18
A.3 Board – Top Layer .....	19
A.4 Board – Top Copper .....	20
A.5 Board – Mid Layer 1 .....	21
A.6 Board – Mid Layer 2 .....	22
A.7 Board – Bottom Copper .....	23
A.8 Board – Bottom Layer .....	24
 <b>Appendix B. Bill of Materials (BOM).....</b>	<b>25</b>
<b>Worldwide Sales and Service .....</b>	<b>28</b>

# MIC4609 Evaluation Board User's Guide

---

NOTES:

---

---

## Preface

---

---

### NOTICE TO CUSTOMERS

All documentation becomes dated, and this manual is no exception. Microchip tools and documentation are constantly evolving to meet customer needs, so some actual dialogs and/or tool descriptions may differ from those in this document. Please refer to our website ([www.microchip.com](http://www.microchip.com)) to obtain the latest documentation available.

Documents are identified with a “DS” number. This number is located on the bottom of each page, in front of the page number. The numbering convention for the DS number is “DSXXXXXXXXA”, where “XXXXXXXX” is the document number and “A” is the revision level of the document.

For the most up-to-date information on development tools, see the MPLAB® IDE online help. Select the Help menu, and then Topics to open a list of available online help files.

## INTRODUCTION

This chapter contains general information that will be useful to know before using the MIC4609 Evaluation Board. Items discussed in this chapter include:

- Document Layout
- Conventions Used in This Guide
- Recommended Reading
- The Microchip Web Site
- Customer Support
- Revision History

## DOCUMENT LAYOUT

This document describes how to install the MIC4609 Evaluation Board. It also describes how to operate the Evaluation Board. The manual layout is as follows:

- **Chapter 1. “Product Overview”** – Important information about the MIC4609 Evaluation Board.
- **Chapter 2. “Installation and Operation”** – Includes instructions on how to get started with the MIC4609 Evaluation Board.
- **Appendix A. “Schematic and Layouts”** – Shows the schematic and layout diagrams for the MIC4609 Evaluation Board.
- **Appendix B. “Bill of Materials (BOM)”** – Lists the parts used to build the MIC4609 Evaluation Board.

## CONVENTIONS USED IN THIS GUIDE

This manual uses the following documentation conventions:

### DOCUMENTATION CONVENTIONS

Description	Represents	Examples
<b>Arial font:</b>		
Italic characters	Referenced books	<i>MPLAB<sup>®</sup> IDE User's Guide</i>
	Emphasized text	...is the <i>only</i> compiler...
Initial caps	A window	the Output window
	A dialog	the Settings dialog
	A menu selection	select Enable Programmer
Quotes	A field name in a window or dialog	"Save project before build"
Underlined, Italic text with right angle bracket	A menu path	<u><i>File&gt;Save</i></u>
Bold characters	A dialog button	Click <b>OK</b>
	A tab	Click the <b>Power</b> tab
N'Rnnnn	A number in verilog format, where N is the total number of digits, R is the radix and n is a digit.	4'b0010, 2'hF1
Text in angle brackets < >	A key on the keyboard	Press <Enter>, <F1>
<b>Courier New font:</b>		
Plain Courier New	Sample source code	#define START
	Filenames	autoexec.bat
	File paths	c:\mcc18\h
	Keywords	_asm, _endasm, static
	Command-line options	-Opa+, -Opa-
	Bit values	0, 1
	Constants	0xFF, 'A'
Italic Courier New	A variable argument	<i>file.o</i> , where <i>file</i> can be any valid filename
Square brackets [ ]	Optional arguments	mcc18 [options] <i>file</i> [options]
Curly brackets and pipe character: {   }	Choice of mutually exclusive arguments; an OR selection	errorlevel {0 1}
Ellipses...	Replaces repeated text	var_name [, var_name...]
	Represents code supplied by user	void main (void) { ... }

## RECOMMENDED READING

This user's guide describes how to use MIC4609 Evaluation Board. Another useful document is listed below. The following Microchip document is available and recommended as supplemental reference resource:

- **MIC4609 Data Sheet – "600V 3-Phase MOSFET/IGBT Driver" (DS20005531A)**



## THE MICROCHIP WEBSITE

Microchip provides online support via our website at [www.microchip.com](http://www.microchip.com). This website is used as a means to make files and information easily available to customers. Accessible by using your favorite Internet browser, the website contains the following information:

- **Product Support** – Data sheets and errata, application notes and sample programs, design resources, user's guides and hardware support documents, latest software releases and archived software
- **General Technical Support** – Frequently Asked Questions (FAQs), technical support requests, online discussion groups, Microchip consultant program member listing
- **Business of Microchip** – Product selector and ordering guides, latest Microchip press releases, listing of seminars and events, listings of Microchip sales offices, distributors and factory representatives.

## CUSTOMER SUPPORT

Users of Microchip products can receive assistance through several channels:

- Distributor or Representative
- Local Sales Office
- Field Application Engineer (FAE)
- Technical Support

Customers should contact their distributor, representative or field application engineer (FAE) for support. Local sales offices are also available to help customers. A listing of sales offices and locations is included in the back of this document.

Technical support is available through the website at:  
<http://www.microchip.com/support>.

## REVISION HISTORY

### Revision A (March 2016)

- Original release of this document.

NOTES:

---

---

## Chapter 1. Product Overview

---

---

### 1.1 INTRODUCTION

This chapter provides an overview of the MIC4609 Evaluation Board and covers the following topics:

- MIC4609 Short Overview
- What is the MIC4609 Evaluation Board?
- MIC4609 Evaluation Board Kit Contents

### 1.2 MIC4609 SHORT OVERVIEW

The MIC4609 Evaluation Board is a 600V, 3-Phase driver that can be used with either IGBTs or MOSFETs. The MIC4609 features a 300 ns typical input filtering time to prevent unwanted pulses and a 550 ns of propagation delay. The board is available in an 28-pin wide SOIC package, with an operating junction temperature range of  $-40^{\circ}\text{C}$  to  $+125^{\circ}\text{C}$ .

### 1.3 WHAT IS THE MIC4609 EVALUATION BOARD?

The board is comprised of the MIC4609 3-phase driver, 6 IGBTs and provisions for current/voltage sensing. Right angle header J1 provides an interface to a controller board for input drive signals, control signals and  $V_{DD}/AV_{DD}$  supply voltages. The input drive signals may also be accessed with jumpers J2, J3, J5, J6, J10 and J11. TP4 and J16 are connected to the  $V_{DD}$  supply voltage. The high voltage  $V_{BUS}$ , power ground and the 3-phase motor connections are made through connector J9.

### 1.4 MIC4609 EVALUATION BOARD KIT CONTENTS

The MIC4609 Evaluation Board includes the following items:

- MIC4609 Evaluation Board (ADM00749)
- Important Information Sheet

# MIC4609 Evaluation Board User's Guide

---

NOTES:

## Chapter 2. Installation and Operation

### 2.1 SYSTEM AND CONFIGURATION REQUIREMENTS

The MIC4609 Evaluation Board requires a  $V_{DD}$  power supply with an output between 10V and 20V, an  $AV_{DD}$  supply of 3.3V or 5V and a high voltage  $V_{BUS}$  power supply that is used to driver the Motor or other load. Do not exceed 450V on  $V_{BUS}$  unless C17 is removed.

**Note:** The evaluation board does not have reverse polarity protection. Applying a negative voltage to the  $V_{BUS}$  (J16),  $V_{AV_{DD}}$  (J1.12) or  $V_{DD}$  (J16 or J1.10) terminals may damage the device. Do not exceed 450V on  $V_{BUS}$  due to the 450V rating of the 10  $\mu$ F Aluminum Electrolytic capacitor (C17). Remove C17 if voltages between 450V and 600V are required.

### 2.2 CIRCUIT DESCRIPTION

The MIC4609 driver stage interfaces the incoming PWM signals to the IGBT power stage. Refer to the MIC4609 data sheet for detailed information on the driver's operation. [Figure 2-1](#) is a partial schematic showing the components for phase A.

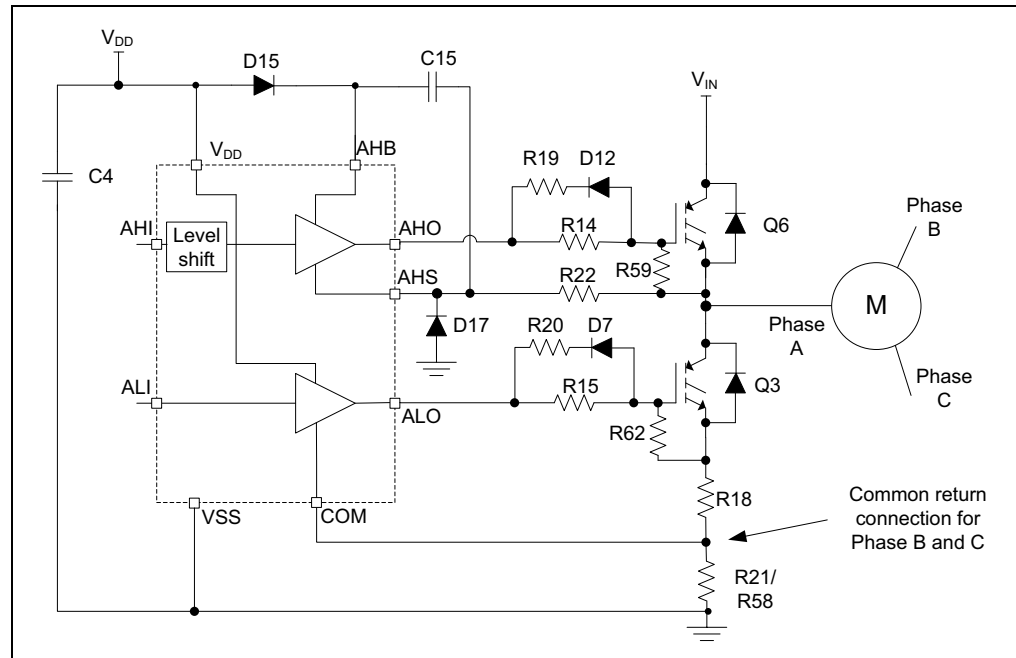

**FIGURE 2-1:** Phase A Circuitry

A resistor diode network is connected between the high and low-side driver output and the IGBT gate. Resistors R14 and R15 limit the driver output current into the gate, which slows down both the turn-on and turn-off of the IGBTs. The diode resistor combination in parallel with the series resistors (R19/D12 and R20/D7) allows the turn off to be faster than the turn-on.

# MIC4609 Evaluation Board User's Guide

---

Resistor R22 and diode D17 clamp the HS pin to prevent it from going too negative. This can occur when the high-side IGBT turns off and the motor current freewheels through the low-side IGBT (Q3).

Resistors R59 and R62 prevent charge from building up on the gates (and causing shoot-through current if both IGBTs turn-on) when  $V_{IN}$  is present but  $V_{DD}$  is not.

Current sense resistors in Phase A (R18) and Phase B (R35, not shown) provide a current signal to the controller for FOC or similar control architectures. Phase C does not have a sense resistor.

Parallel resistors R21 and R58 sense the current from all three phases and are used for overcurrent detection. The voltage across these resistors is sensed by the OC circuitry in the MIC4609, which shuts off the driver outputs if the OC threshold is exceeded.

## 2.2.1 Overcurrent and Fault circuitry

The MIC4609 can detect an overcurrent condition by sensing the voltage across a current sense resistor (R21/R58) and comparing it to an internal reference. If the peak voltage sensed exceeds the reference, the output drivers are turned off for a period of time before being allowed to turn back on. The delay is set with capacitor C31. Refer to the MIC4609 data sheet for additional information on setting the delay.

The FAULT pin goes low during the overcurrent event. This signal can be read by the controller to indicate a fault condition. The FAULT pin is pulled up to  $AV_{DD}$  with a 100 k $\Omega$  resistor. The fault signal can be monitored on TP1 or on pin 7 of jumper J1.

## 2.2.2 Enable Pin (EN)

A 3-pin header (J8) connected to the enable pin allows it to be set high (ON) or low (OFF). When the jumper is set high, it is pulled up to  $AV_{DD}$  through a 1 k $\Omega$  resistor. The signal is connected to pin 9 of J1. A high level on the EN pin turns ON the internal bias' in the driver and allows the driver to operate normally. Setting the EN pin low puts the device into a low IQ state and turns off all six driver outputs.

An external connection may be used to set the EN pin state. When using an external connection, make sure the EN pin voltage does not exceed  $V_{DD}$ .

## 2.2.3 Input Pins (xHI/xLI)

Connections to the six input pins are made through connector J1 (pins 1-6) or through individual headers (J2, J3, J5, J6, J10, and J11). The individual headers can be used to monitor the signals or to set them high or low.

Resistors in series with the inputs (as well as the EN and FAULT pins) can be used to limit current back to the controller if there is a fault condition or reverse voltage connection.

## 2.2.4 Power and Motor connections

There are four voltage dividers on the board that provide sensing feedback to the controller:

- VBUS\_SNS monitors the high voltage BUS
- FB\_PHA, FB\_PHB and FB\_PHC monitor the phase voltages.

RECN is the reconstructed neutral voltage. These signals are filtered and clamped to  $AV_{DD}$  for noise and surge overvoltage protection.

The sense voltage is the output of the voltage dividers and can be calculated using the following equation:

**EQUATION 2-1:**

$$V_{FB\_PHA} = V_{PhaseA} \times \left( \frac{R41}{R41 + R44 + R48} \right)$$

Similar calculations are made for Phases B, C and the  $V_{BUS}$  sense.

The resistor values on the board generate a 2V FB signal for a 300V BUS or phase voltage. If higher or lower voltage motors are used, the resistor divider values must be recalculated.

## 2.2.5 Power Stage and Motor connections

The  $V_{BUS}$  and power GND connections as well as the three motor phase connections are accessed through connector J9. In the existing evaluation board configuration, the maximum voltage on  $V_{BUS}$  is 450V DC. This is limited by the voltage rating of the electrolytic capacitor, C17. If the capacitor is removed,  $V_{BUS}$  can increase to 600V.

Locations for an RC snubber for each of the phase nodes are located on the back of the board. These are not populated but are available to attenuate ringing if necessary.

# MIC4609 Evaluation Board User's Guide

---

NOTES:





# MIC4609 EVALUATION BOARD USER'S GUIDE

---

---

## Appendix A. Schematic and Layouts

---

---

### A.1 INTRODUCTION

This appendix contains the following schematics and layouts for the MIC4609 Evaluation Board:

- Board – Schematic
- Board – Top Layer
- Board – Top Copper
- Board – Mid Layer 1
- Board – Mid Layer 2
- Board – Bottom Copper
- Board – Bottom Layer

### A.2 BOARD – SCHEMATIC

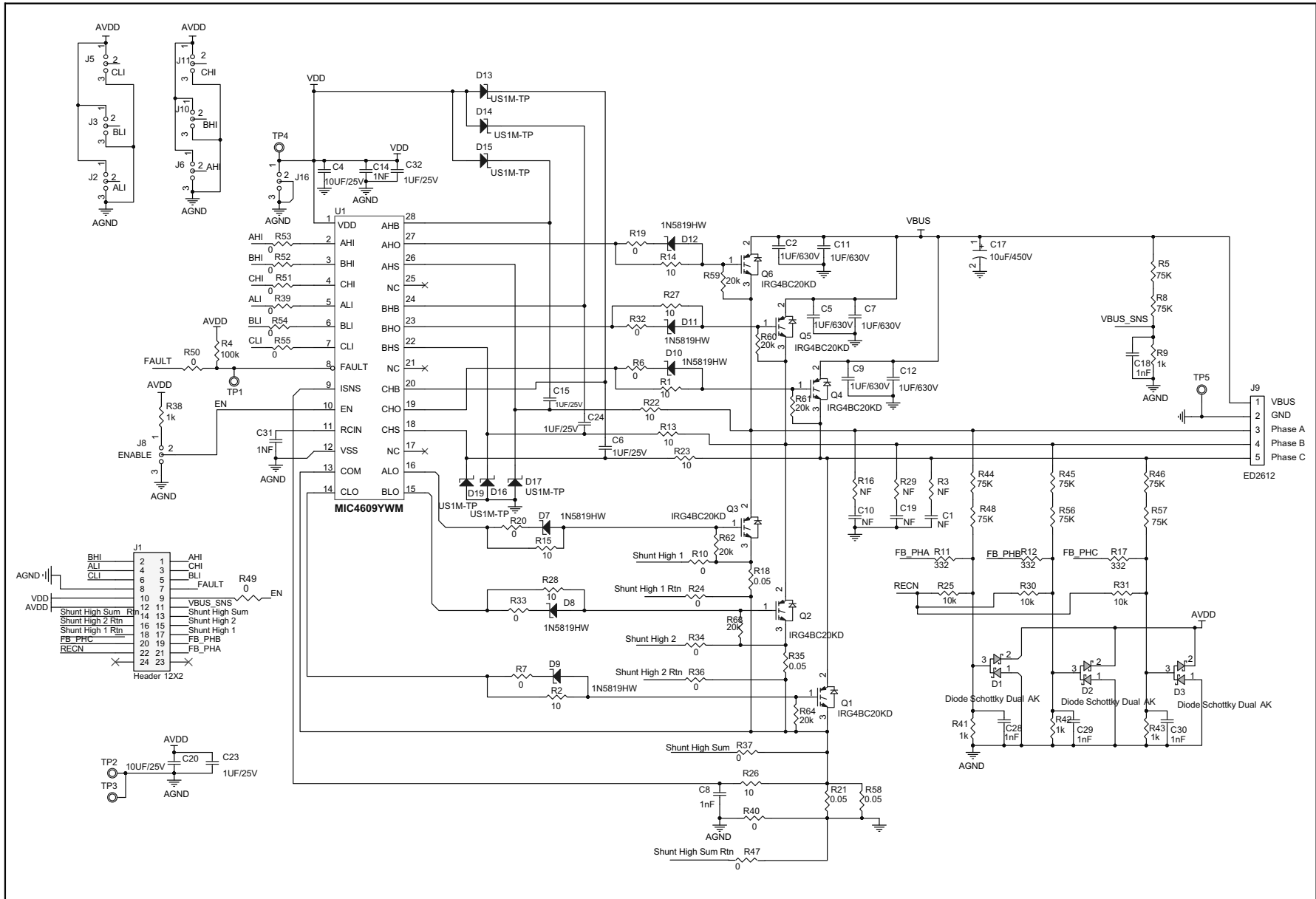

## A.3 BOARD – TOP LAYER

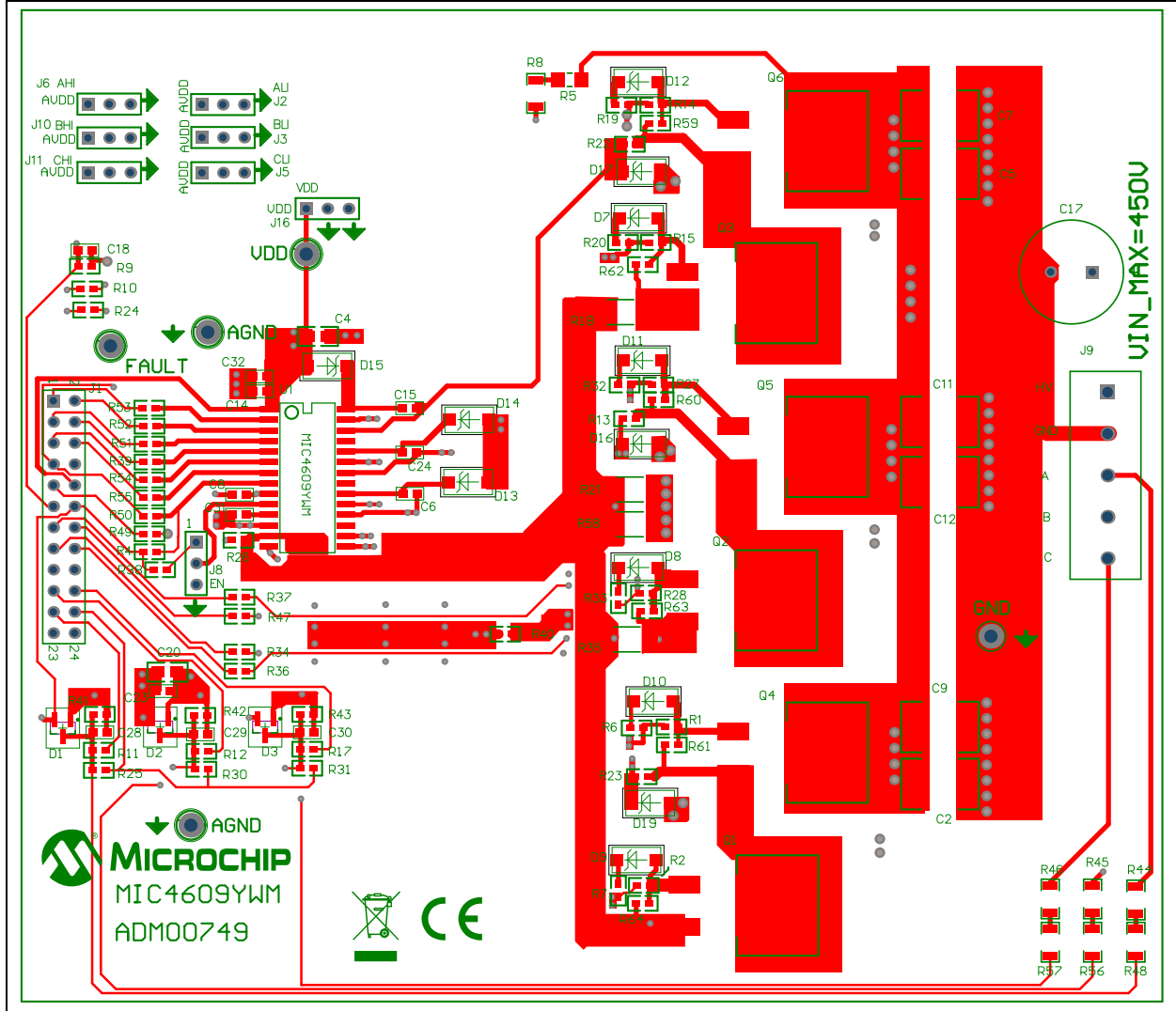

# MIC4609 Evaluation Board User's Guide

## A.4 BOARD – TOP COPPER

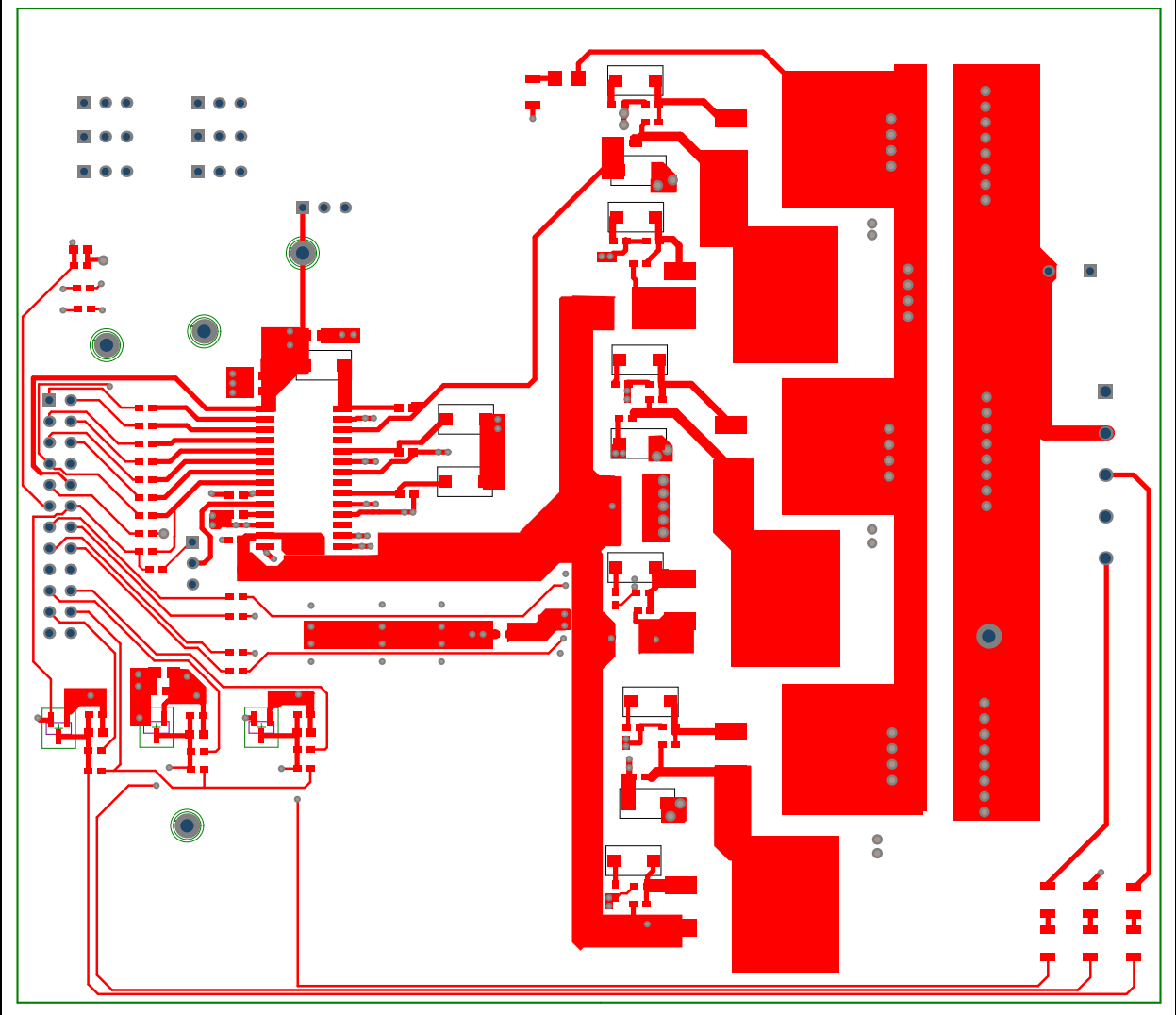

## A.5 BOARD – MID LAYER 1

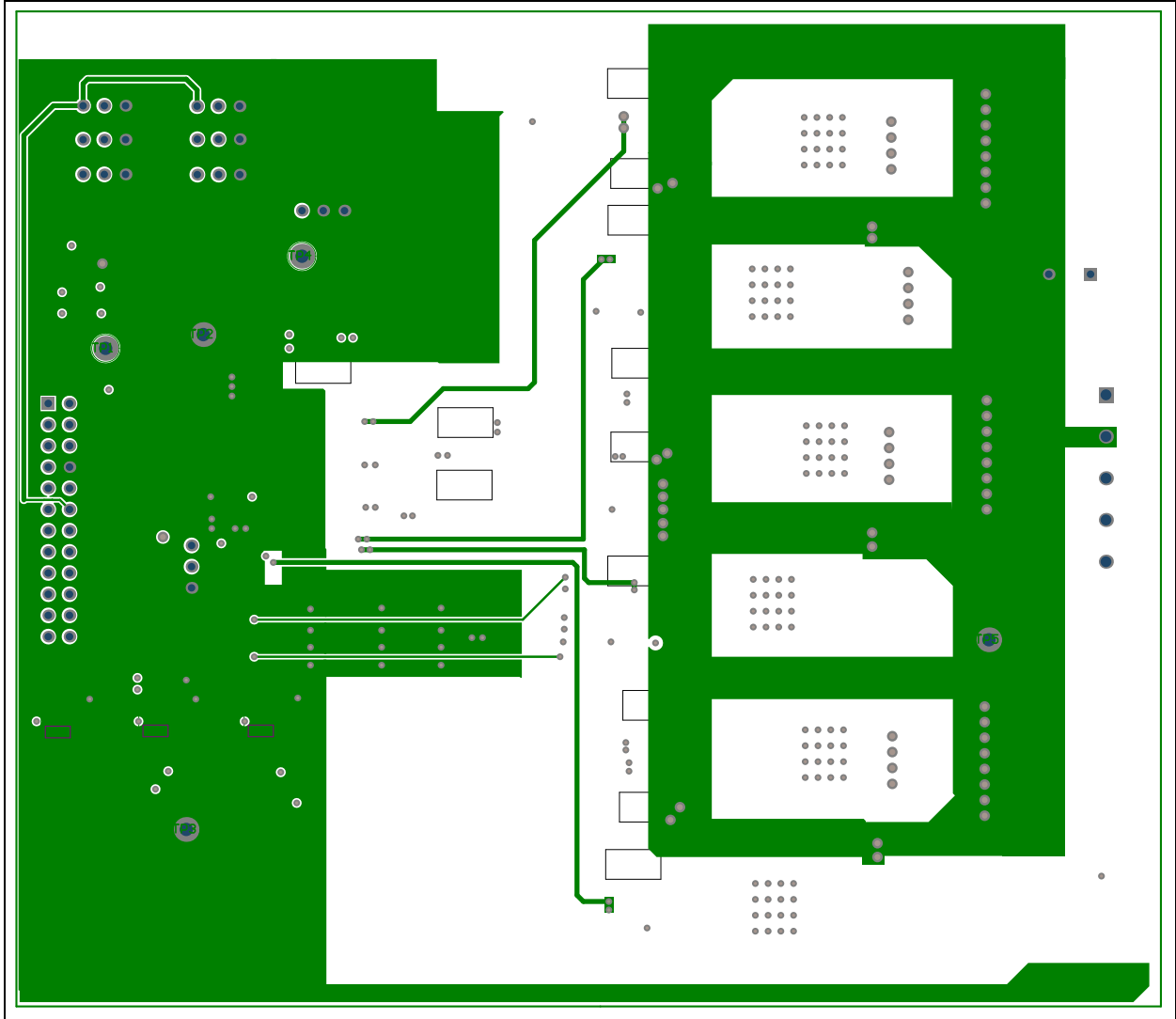

# MIC4609 Evaluation Board User's Guide

## A.6 BOARD – MID LAYER 2

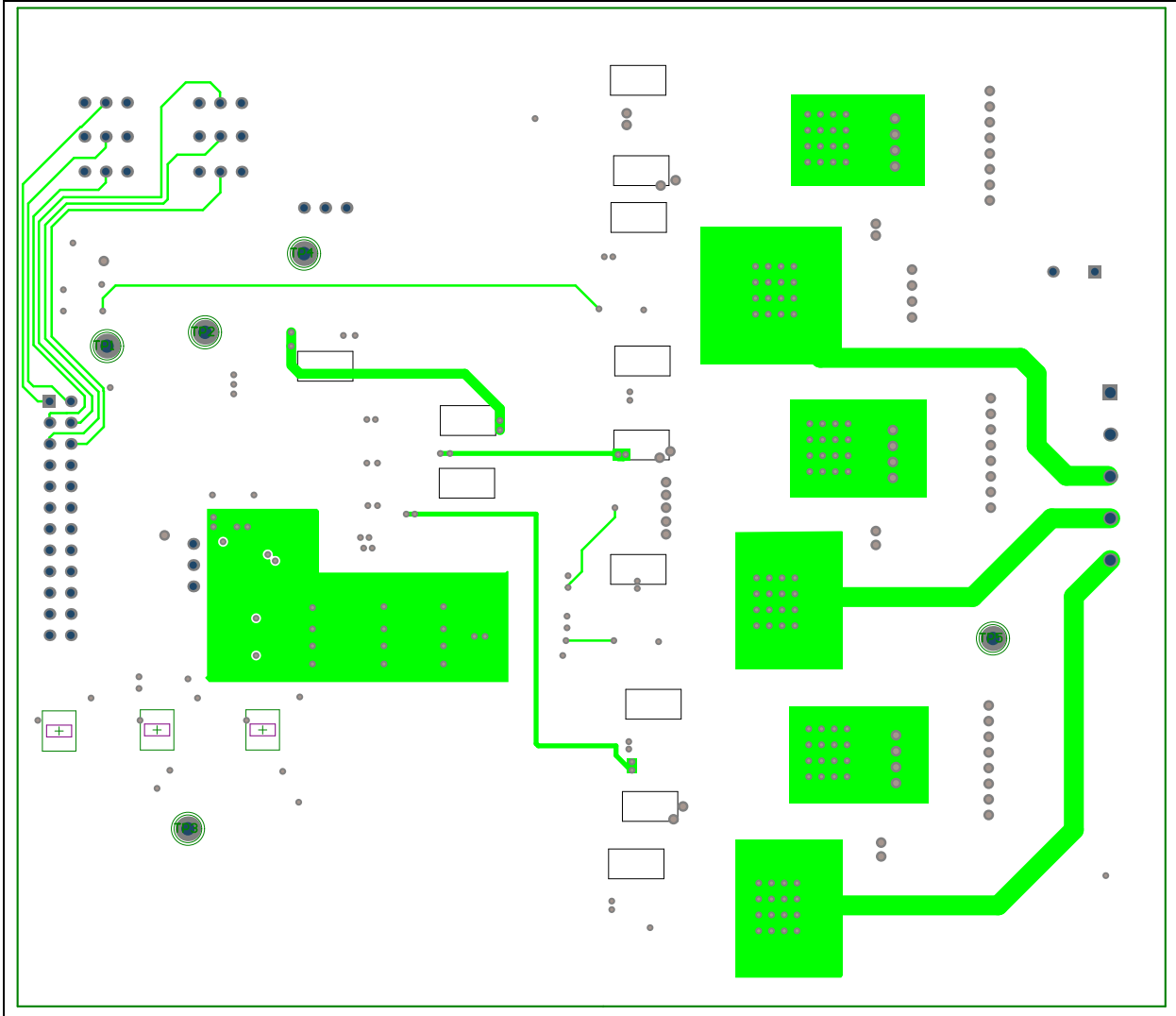

## A.7 BOARD – BOTTOM COPPER

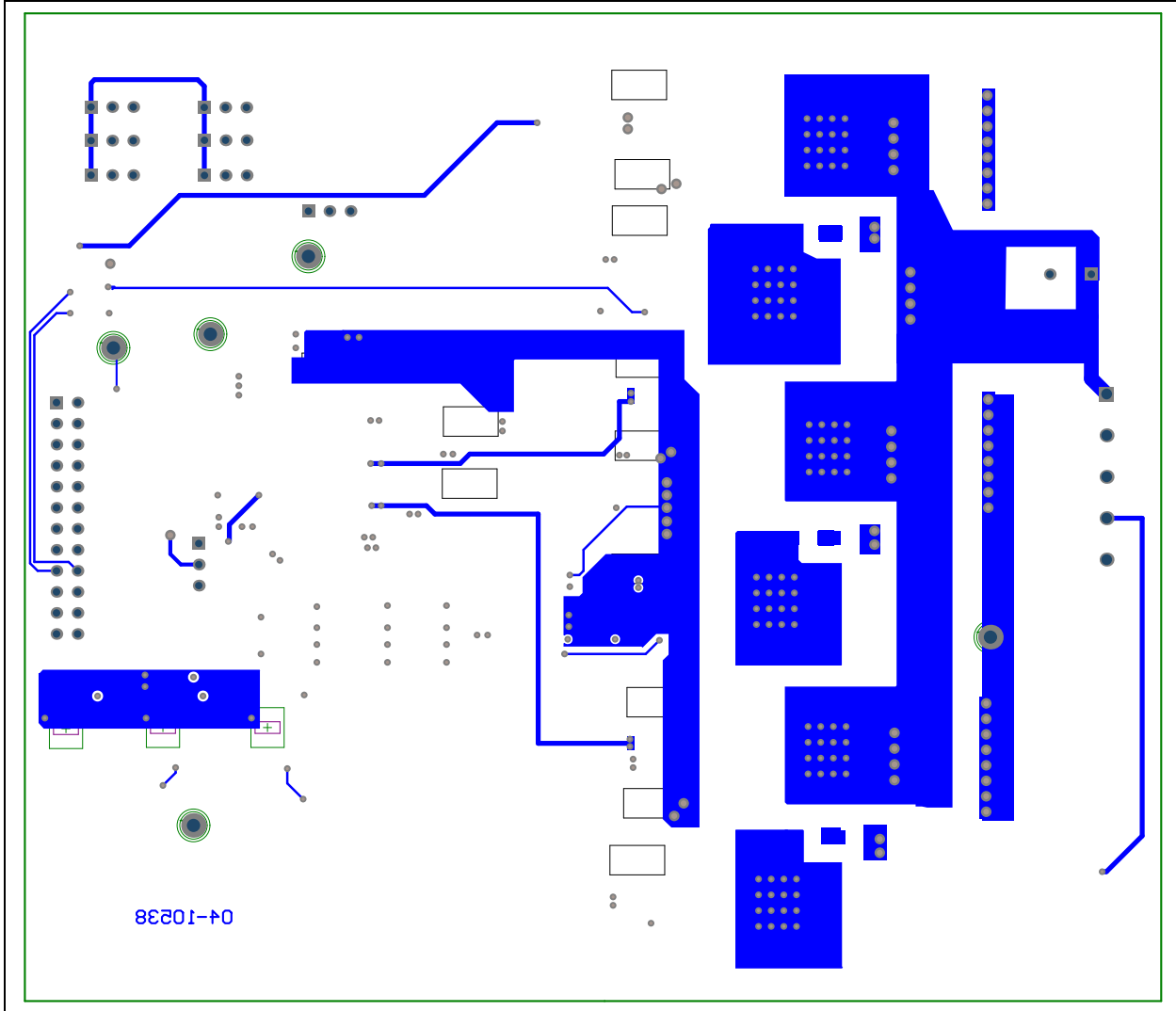

# MIC4609 Evaluation Board User's Guide

## A.8 BOARD – BOTTOM LAYER

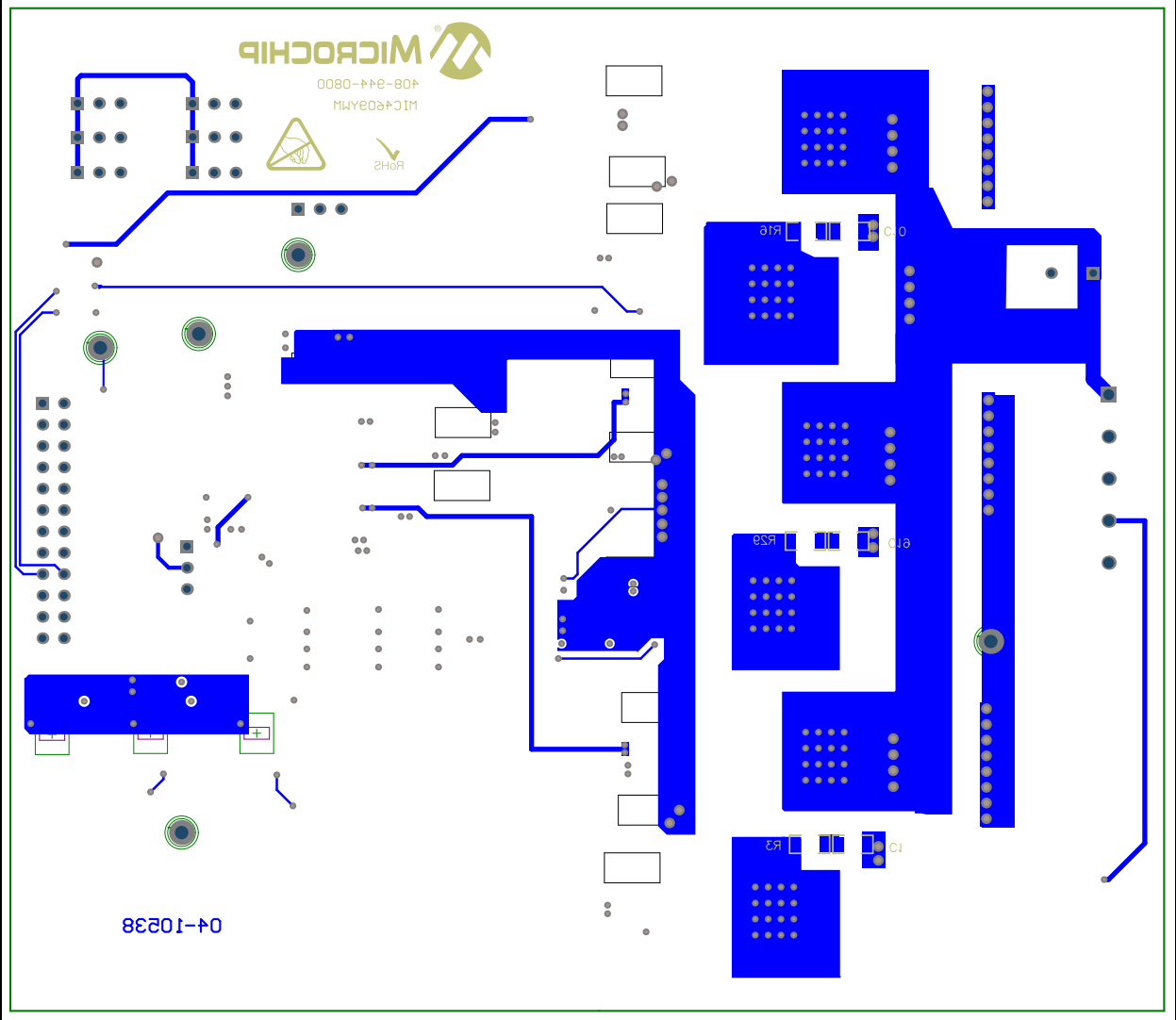



**Appendix B. Bill of Materials (BOM)**

**TABLE B-1: BILL OF MATERIALS (BOM)**

Qty.	Reference	Description	Manufacturer	Part Number
3	C1, C10, C19	1206 size capacitor <b>DO NOT POPULATE</b>		
6	C2, C5, C7, C9, C11, C12	1 $\mu$ F/630V	TDK Corporation	CKG57NX7T2J105M500JH
2	C4, C20	10 $\mu$ F/25V	TDK Corporation	C2012X5R1E106K085AC
5	C6, C15, C23, C24, C32	1 $\mu$ F/25V	TDK Corporation	C1608X7R1E105K080AB
7	C8, C14, C18, C28, C29, C30, C31	1nF/50V	TDK Corporation	C1608X7R1H102K080AE
1	C17	10 $\mu$ F/450V Al. El	Panasonic® - ECG	EEU-EE2W100
1	U1	600V, 3-phase driver	Microchip Technology, Inc.	<b>MIC4609YWM</b>
3	R3, R16, R29	1206 size resistor <b>DO NOT POPULATE</b>		
1	R4	100K, 1%, 1/4W	Panasonic- ECG	ERJ-3EKF1003V
10	R1, R2, R13, R14, R15, R22, R23, R26, R27, R28	10, 1%, 1/10W	Panasonic- ECG	ERJ-3EKF10R0V
5	R9, R38, R41, R42, R43	1k, 1%, 1/10W	Panasonic- ECG	ERJ-3EKF1001V
3	R25, R30, R31	10K, 1%, 1/10W	Panasonic- ECG	ERJ-3EKF1002V
8	R5, R8, R44, R45, R46, R48, R56, R57	75K, 1%, 1/4W	Panasonic- ECG	ERJ-8ENF7502V
21	R6, R7, R10, R19, R20, R24, R32, R33, R34, R36, R37, R39, R40, R47, R49, R50, R51, R52, R53, R54, R55	0, 1%, 1/10W	Panasonic- ECG	ERJ-3GEY0R00V
3	R11, R12, R17	332 $\Omega$ , 1%, 1/10W	Panasonic- ECG	ERJ-3EKF3320V
4	R18, R21, R35, R58	0.05 $\Omega$ , 1W 1%	Panasonic- ECG	ERJ-M1WSF50MU
6	R59, R60, R61, R62, R63, R64	20K, 1%, 1/10W	Panasonic- ECG	ERJ-3EKF2002V

**Note 1:** The components listed in this Bill of Materials are representative of the PCB assembly. The released BOM used in manufacturing uses all RoHS-compliant components.

# MIC4609 Evaluation Board User's Guide

---

**TABLE B-2: BILL OF MATERIALS (BOM) - MECHANICAL PARTS**

Qty	Reference	Description	Manufacturer	Part Number
3	D1, D2, D3	Diode Schottky Dual AK 40V/200mA	Diodes Incorporated®	BAS40-04
6	D7, D8, D9, D10, D11, D12	Schottky, 1A/40V	Diodes Incorporated	1N5819HW
6	D13, D14, D15, D16, D17, D19	100V/1A Ultra fast diode	Diodes Incorporated	US1M-TP
1	J1	Header, 12-Pin, dual row, right angle	FCI	68021-224HLF
8	J2, J3, J5, J6, J8, J10, J11, J16	Header, 3-pin	FCI	68000-103HLF
1	J9	5 position terminal block	On-Shore Technology, Inc.	ED2612
6	Q1, Q2, Q3, Q4, Q5, Q6 ( <b>Note 2</b> )	IGBT	Infineon Technologies AG	IRG4BC20KD
		IGBT	Infineon Technologies AG	IKB06N60T
		IGBT	Fairchild Semiconductor®	SGW10N60RUFD
		IGBT	STMicroelectronics	STGB10NC60KD

**Note 1:** The components listed in this Bill of Materials are representative of the PCB assembly. The released BOM used in manufacturing uses all RoHS-compliant components.

**2:** Note that only one set of six IGBTs are used at a time. You can choose the IGBT produced by one of the three listed manufacturers.

# Bill of Materials (BOM)

---

NOTES:



# MICROCHIP

## Worldwide Sales and Service

### AMERICAS

#### Corporate Office

2355 West Chandler Blvd.  
Chandler, AZ 85224-6199

Tel: 480-792-7200

Fax: 480-792-7277

Technical Support:

[http://www.microchip.com/  
support](http://www.microchip.com/support)

Web Address:

[www.microchip.com](http://www.microchip.com)

#### Atlanta

Duluth, GA

Tel: 678-957-9614

Fax: 678-957-1455

#### Austin, TX

Tel: 512-257-3370

#### Boston

Westborough, MA

Tel: 774-760-0087

Fax: 774-760-0088

#### Chicago

Itasca, IL

Tel: 630-285-0071

Fax: 630-285-0075

#### Cleveland

Independence, OH

Tel: 216-447-0464

Fax: 216-447-0643

#### Dallas

Addison, TX

Tel: 972-818-7423

Fax: 972-818-2924

#### Detroit

Novi, MI

Tel: 248-848-4000

#### Houston, TX

Tel: 281-894-5983

#### Indianapolis

Noblesville, IN

Tel: 317-773-8323

Fax: 317-773-5453

#### Los Angeles

Mission Viejo, CA

Tel: 949-462-9523

Fax: 949-462-9608

#### New York, NY

Tel: 631-435-6000

#### San Jose, CA

Tel: 408-735-9110

#### Canada - Toronto

Tel: 905-673-0699

Fax: 905-673-6509

### ASIA/PACIFIC

#### Asia Pacific Office

Suites 3707-14, 37th Floor  
Tower 6, The Gateway  
Harbour City, Kowloon

#### Hong Kong

Tel: 852-2943-5100

Fax: 852-2401-3431

#### Australia - Sydney

Tel: 61-2-9868-6733

Fax: 61-2-9868-6755

#### China - Beijing

Tel: 86-10-8569-7000

Fax: 86-10-8528-2104

#### China - Chengdu

Tel: 86-28-8665-5511

Fax: 86-28-8665-7889

#### China - Chongqing

Tel: 86-23-8980-9588

Fax: 86-23-8980-9500

#### China - Dongguan

Tel: 86-769-8702-9880

#### China - Hangzhou

Tel: 86-571-8792-8115

Fax: 86-571-8792-8116

#### China - Hong Kong SAR

Tel: 852-2943-5100

Fax: 852-2401-3431

#### China - Nanjing

Tel: 86-25-8473-2460

Fax: 86-25-8473-2470

#### China - Qingdao

Tel: 86-532-8502-7355

Fax: 86-532-8502-7205

#### China - Shanghai

Tel: 86-21-5407-5533

Fax: 86-21-5407-5066

#### China - Shenyang

Tel: 86-24-2334-2829

Fax: 86-24-2334-2393

#### China - Shenzhen

Tel: 86-755-8864-2200

Fax: 86-755-8203-1760

#### China - Wuhan

Tel: 86-27-5980-5300

Fax: 86-27-5980-5118

#### China - Xian

Tel: 86-29-8833-7252

Fax: 86-29-8833-7256

### ASIA/PACIFIC

#### China - Xiamen

Tel: 86-592-2388138

Fax: 86-592-2388130

#### China - Zhuhai

Tel: 86-756-3210040

Fax: 86-756-3210049

#### India - Bangalore

Tel: 91-80-3090-4444

Fax: 91-80-3090-4123

#### India - New Delhi

Tel: 91-11-4160-8631

Fax: 91-11-4160-8632

#### India - Pune

Tel: 91-20-3019-1500

#### Japan - Osaka

Tel: 81-6-6152-7160

Fax: 81-6-6152-9310

#### Japan - Tokyo

Tel: 81-3-6880-3770

Fax: 81-3-6880-3771

#### Korea - Daegu

Tel: 82-53-744-4301

Fax: 82-53-744-4302

#### Korea - Seoul

Tel: 82-2-554-7200

Fax: 82-2-558-5932 or

82-2-558-5934

#### Malaysia - Kuala Lumpur

Tel: 60-3-6201-9857

Fax: 60-3-6201-9859

#### Malaysia - Penang

Tel: 60-4-227-8870

Fax: 60-4-227-4068

#### Philippines - Manila

Tel: 63-2-634-9065

Fax: 63-2-634-9069

#### Singapore

Tel: 65-6334-8870

Fax: 65-6334-8850

#### Taiwan - Hsin Chu

Tel: 886-3-5778-366

Fax: 886-3-5770-955

#### Taiwan - Kaohsiung

Tel: 886-7-213-7828

#### Taiwan - Taipei

Tel: 886-2-2508-8600

Fax: 886-2-2508-0102

#### Thailand - Bangkok

Tel: 66-2-694-1351

Fax: 66-2-694-1350

### EUROPE

#### Austria - Wels

Tel: 43-7242-2244-39

Fax: 43-7242-2244-393

#### Denmark - Copenhagen

Tel: 45-4450-2828

Fax: 45-4485-2829

#### France - Paris

Tel: 33-1-69-53-63-20

Fax: 33-1-69-30-90-79

#### Germany - Dusseldorf

Tel: 49-2129-3766400

#### Germany - Karlsruhe

Tel: 49-721-625370

#### Germany - Munich

Tel: 49-89-627-144-0

Fax: 49-89-627-144-44

#### Italy - Milan

Tel: 39-0331-742611

Fax: 39-0331-466781

#### Italy - Venice

Tel: 39-049-7625286

#### Netherlands - Drunen

Tel: 31-416-690399

Fax: 31-416-690340

#### Poland - Warsaw

Tel: 48-22-3325737

#### Spain - Madrid

Tel: 34-91-708-08-90

Fax: 34-91-708-08-91

#### Sweden - Stockholm

Tel: 46-8-5090-4654

#### UK - Wokingham

Tel: 44-118-921-5800

Fax: 44-118-921-5820

07/14/15

# Mouser Electronics

Authorized Distributor

Click to View Pricing, Inventory, Delivery & Lifecycle Information:

[Microchip:](#)

[ADM00749](#)