

THIS COPY IS PROVIDED ON A RESTRICTED BASIS AND IS NOT TO BE USED IN ANY WAY DETRIMENTAL TO THE INTERESTS OF PANDUIT CORP.

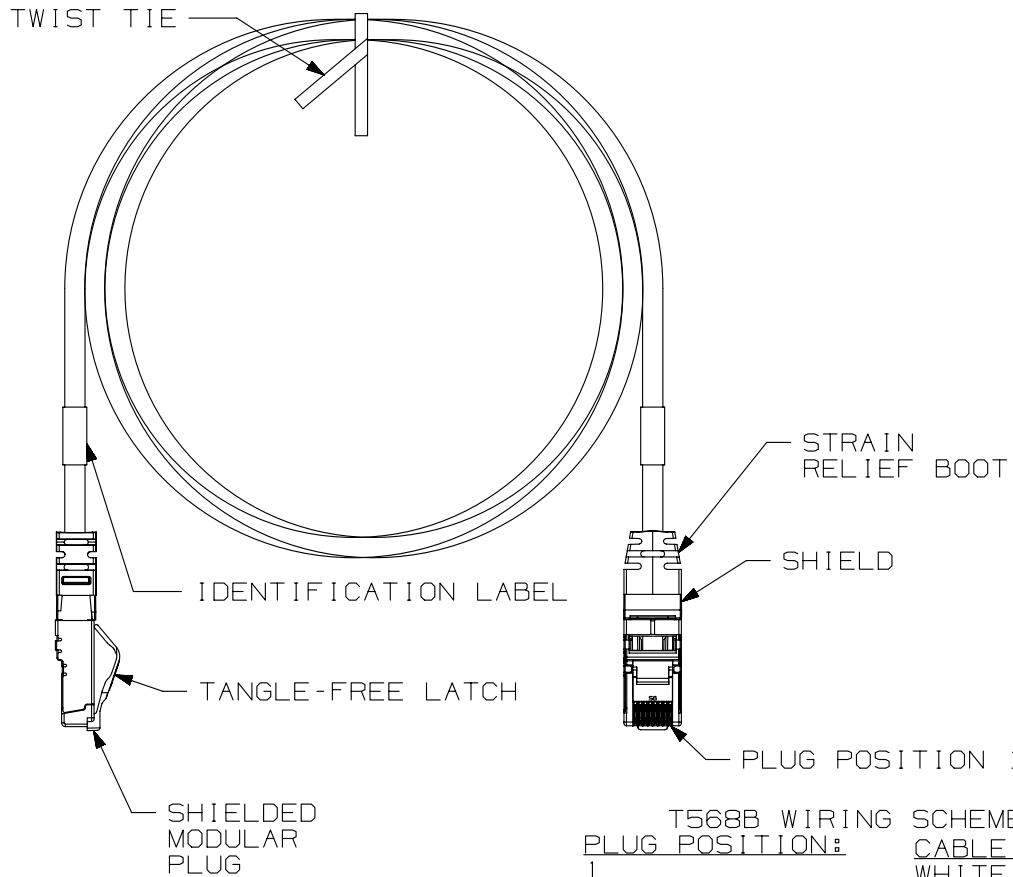

NOTES:

- **1. SEE CURRENT CATALOG FOR VARIOUS APPLICATIONS AND TO INDICATE COLOR AND OR PACKAGE QUANTITY.
- 2. SEE CATALOG FOR A COMPLETE LIST OF PARTS APPLICABLE FOR USE WITH THIS PART.
- 3. TERMINATED WITH (8 POSITION) SHIELDED MODULAR PLUGS AT BOTH ENDS PER T568B.
- 4. CONSTRUCTED WITH 26AWG STRANDED CAT6 FULLY SHIELDED, TWISTED PAIR LSZH/CM S/FTP PATCH CABLE.
- 5. NOMINAL CABLE JACKET DIAMETER IS 0.248 IN (6.30MM).
- 6. MATERIALS:
 PLUG: POLYCARBONATE
 PLUG SHIELD: PLATED CARTRIDGE BRASS
 CABLE SHIELD: ALUMINUM
 BOOT: TPE

CABLE COLORS	** = COLOR
INTERNATIONAL GRAY	IG
BLACK	BL
BLUE	BU
RED	RD
YELLOW	YL
GREEN	GR
ORANGE	OR
VIOLET	VL

T568B WIRING SCHEME
PLUG POSITION:
 1
 2
 3
 4
 5
 6
 7
 8

CABLE WIRE:
 WHITE/ORANGE
 ORANGE
 WHITE/GREEN
 BLUE
 WHITE/BLUE
 GREEN
 WHITE/BROWN
 BROWN

SEE SHEET 2 FOR PATCH CORD LENGTHS AND PART NUMBERS

PART NUMBER		STP6X**	
TITLE			
TX6A 10GIG SHIELDED PATCH CORDS (CM/LSZH)			
CUSTOMER DRAWING			
ITEM REVISION NAME		M02085BA/27	
DATASET FILE NAME		M02085BA_DC01/27C	
UNLESS OTHERWISE SPECIFIED, DIMENSIONAL TOLERANCES ARE: IN (mm)		MATERIAL:	
.x ±		.xxx ± .010 (.3)	
.xx ± .03 (.8)		ANGLES ±	
DRAWING NUMBER:		02085-01	
DRAWN BY		MDJr	
DATE		8-29-02	
CHK		CEF	
SCALE		NONE	
SHT 1 OF 2		A	

REV	DATE	BY	CHK	APR	DESCRIPTION	ECN
10	4-25-14	BJN	JSP	EJH	REVISED & REDRAWN PREVIOUS REVISIONS REMVD FOR CLARITY	02085-01

D10100DA/14

THIS COPY IS PROVIDED ON A RESTRICTED BASIS AND IS NOT TO BE USED IN ANY WAY DETRIMENTAL TO THE INTERESTS OF PANDUIT CORP.

TX6A 10GIG SHIELDED PATCH CORDS

PANDUIT PART NUMBER	MIN. CABLE LENGTH	PANDUIT PART NUMBER	MIN. CABLE LENGTH
STP6X2**	2 FT.	STP6X0.5M**	0.5 METER
STP6X3**	3 FT.	STP6X1M**	1 METER
STP6X4**	4 FT.	STP6X1.5M**	1.5 METER
STP6X5**	5 FT.	STP6X2M**	2 METERS
STP6X6**	6 FT.	STP6X2.5M**	2.5 METER
STP6X7**	7 FT.	STP6X3M**	3 METERS
STP6X8**	8 FT.	STP6X4M**	4 METERS
STP6X9**	9 FT.	STP6X5M**	5 METERS
STP6X10**	10 FT.	STP6X6M**	6 METERS
STP6X11**	11 FT.	STP6X7M**	7 METERS
STP6X12**	12 FT.	STP6X8M**	8 METERS
STP6X13**	13 FT.	STP6X9M**	9 METERS
STP6X14**	14 FT.	STP6X10M**	10 METERS
STP6X15**	15 FT.	STP6X15M**	15 METERS
STP6X16**	16 FT.	STP6X20M**	20 METERS
STP6X17**	17 FT.	STP6X25M**	25 METERS
STP6X18**	18 FT.	STP6X30M**	30 METERS
STP6X19**	19 FT.	STP6X35M**	35 METERS
STP6X20**	20 FT.	STP6X40M**	40 METERS
STP6X25**	25 FT.		
STP6X30**	30 FT.		
STP6X35**	35 FT.		
STP6X40**	40 FT.		

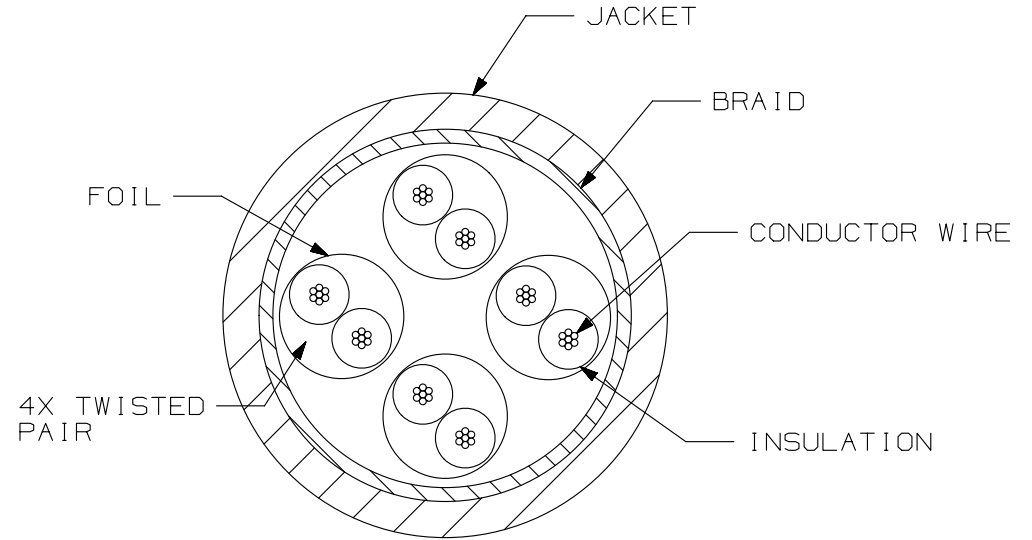

CROSS-SECTIONAL VIEW OF CABLE

PART NUMBER		STP6X**	
TITLE			
TX6A 10GIG SHIELDED PATCH CORDS (CM/LSZH)			
CUSTOMER DRAWING			
ITEM REVISION NAME		M02085BA/27	
DATASET FILE NAME		M02085BA_DC01/27C	
UNLESS OTHERWISE SPECIFIED, DIMENSIONAL TOLERANCES ARE: IN [mm]		MATERIAL:	
.X ±		.xxx ± .010 [.3]	
.xx ± .03 [.8]		ANGLES ±	
		THIRD ANGLE PROJECTION	
DRAWN BY		DATE	
MDJr		8-29-02	
CHK		SCALE	
CEF		NONE	
DRAWING NUMBER:		02085-01	
REV		DATE	
BY		CHK	
APR		DESCRIPTION	
10		4-25-14	
BJN		JSP	
EJH		SEE SHEET A FOR REVISION HISTORY	
ECN		02085-01	
SHT 2 OF 2		SIZE	
A		A	

D10100DA/14