

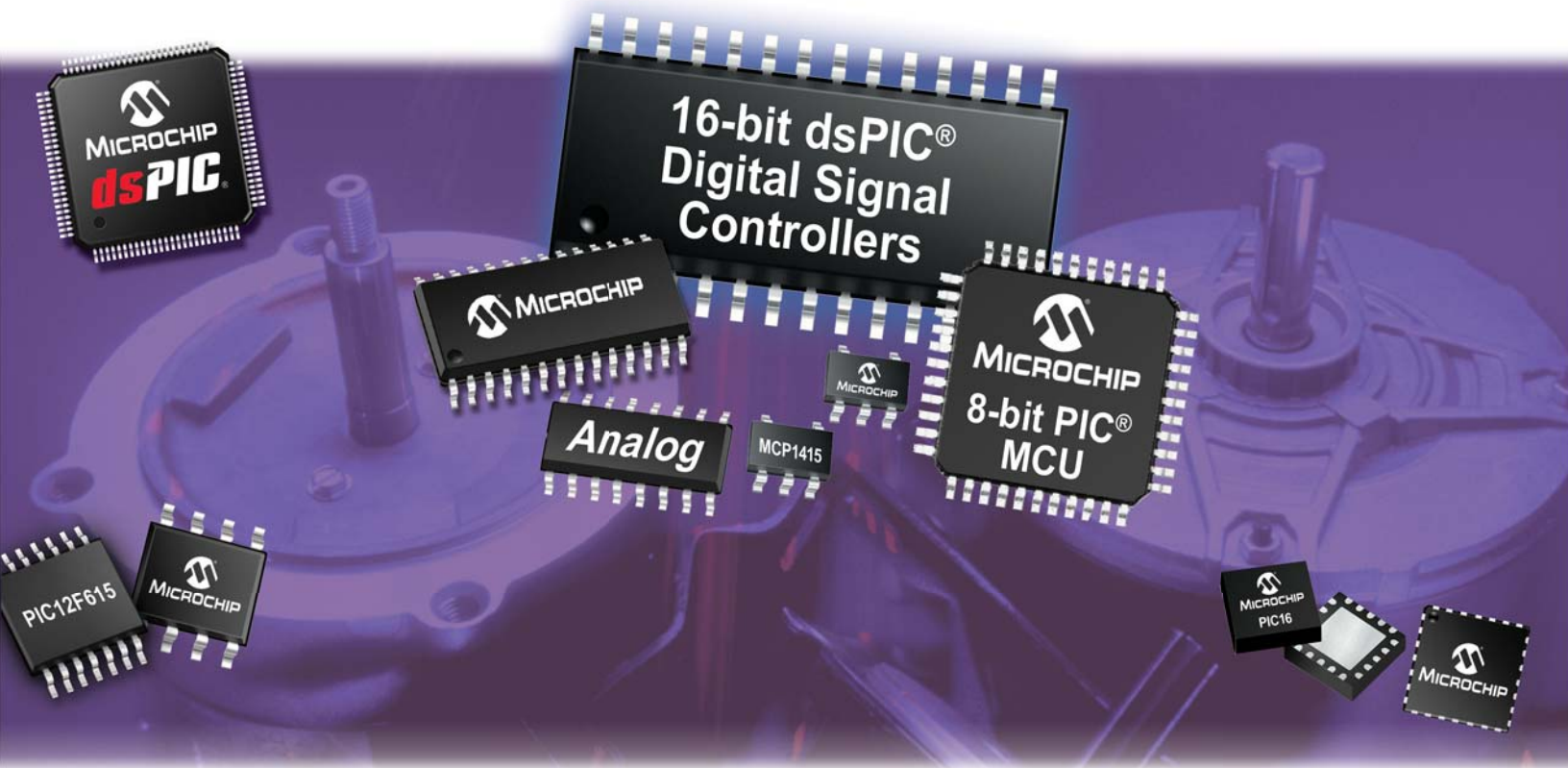

## Motor Control Design Solutions



# Discover Microchip's Comprehensive Motor Control Solutions

Why choose Microchip for your next motor control design? Our 8-bit microcontrollers and 16-bit Digital Signal Controllers contain innovative on-chip peripherals designed specifically for motor control. With motor control devices from 8 to 100 pins, we have the perfect part for every application.

Got a tight schedule? We provide free motor control software with application notes and schematics for most motor control algorithms to shorten your development cycle. Our low-cost development tools are specifically designed for motor control to promote rapid prototyping of custom applications. We offer technical training classes and web seminars to quickly familiarize engineers with our devices and the latest motor control algorithms.

Microchip can provide these products and resources for motor control applications:

- 8 and 16-bit microcontrollers and digital signal controllers
- MOSFET gate drivers
- Analog and Interface products
- Motor control development tools and reference design hardware
- Motor control algorithms and software
- Motor control training and technical support

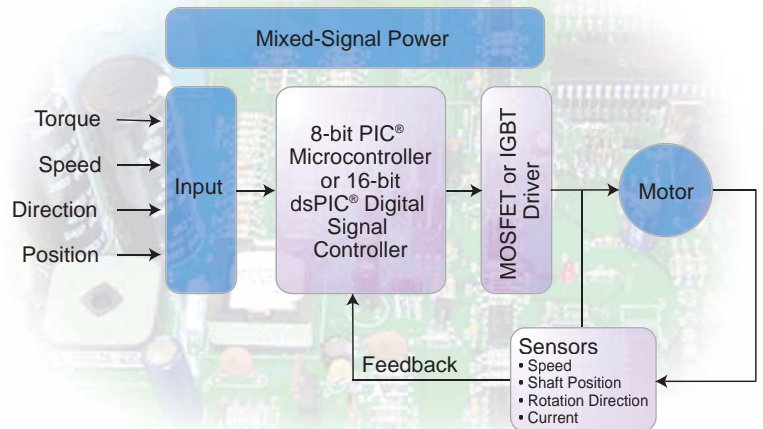

Microchip provides everything a motor control design engineer needs: low-risk product development, lower total system cost, faster time to market, outstanding technical support and dependable delivery and quality.

Don't see what you need? Please ask! Just because you don't see it here doesn't mean that it is not available. As a leader in motor control, Microchip is continuously designing new motor control devices and creating new types of motor control support software.

## Whole Product Solution

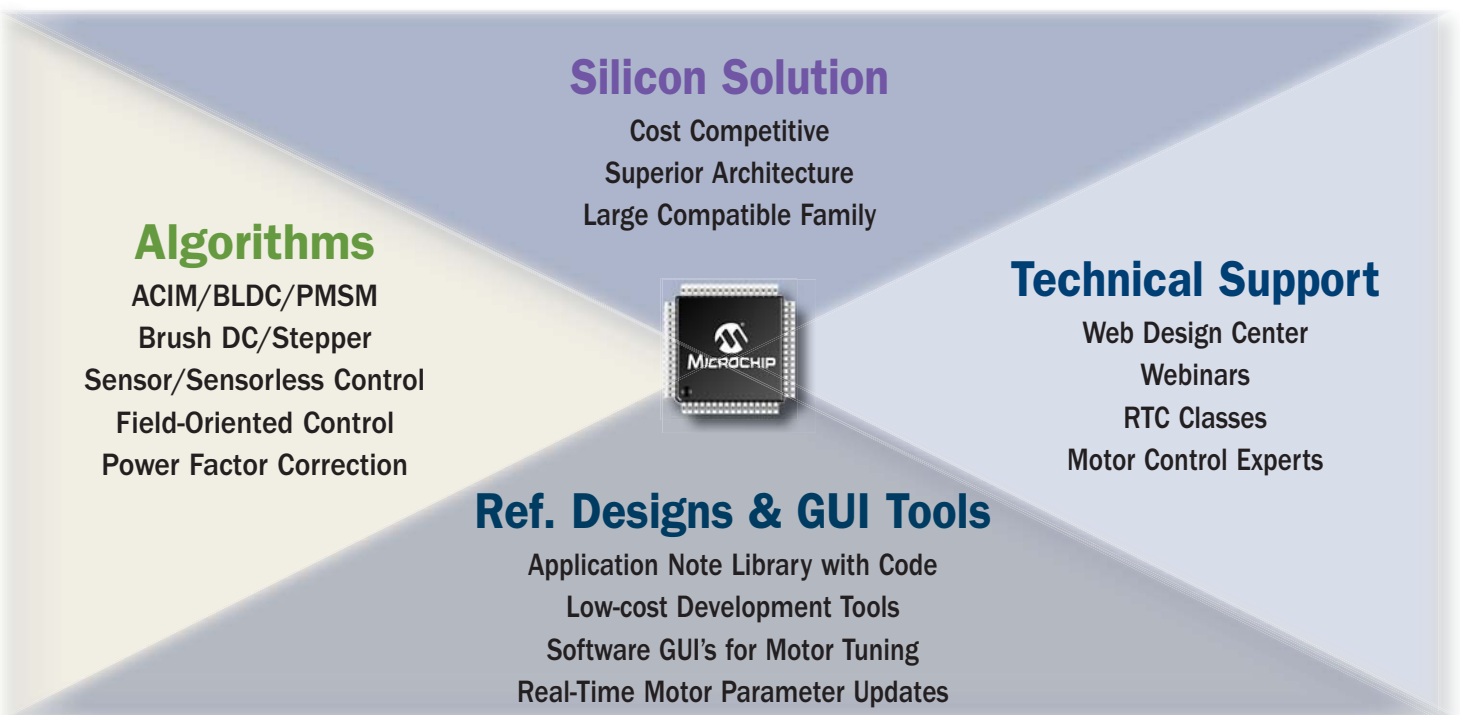

# Which MCU or DSC Should You Choose?

Microchip provides many devices that can be used in motor control applications.

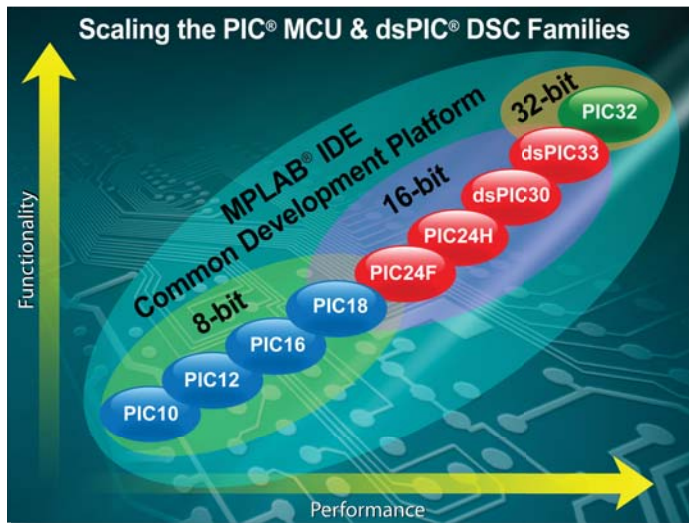

Microchip makes many families of MCUs and DSCs, including 8-, 16- and 32-bit solutions. All of these can be used in motor control applications. However, some families contain special motor control peripherals and features as described below. With all of these families, the motor control designer can choose the level of functionality and performance that is required for the application.

## PIC10F Microcontroller Family

The 6-pin products of the PIC10F family offer the motor control designer an opportunity to use microcontrollers in applications that have historically been void of such devices. Whether it is cost or space constraints, PIC10F microcontrollers address these concerns by providing a pricing structure that makes them nearly disposable with form factors that can easily be implemented into the most space constrained designs. The ADC, comparator and timer peripherals found in the PIC10F device family can be used to provide a user interface for basic on/off control, speed control and other intelligent motor functions. The PIC10F features include:

- Up to 2 MIPS execution speed
- 2x3 DFN or 6-pin SOT-23 package
- Internal oscillator
- Comparator
- 8-bit ADC

## PIC12F and PIC16F Microcontroller Family

The PIC12F and PIC16F product families have an 8-bit CPU that can operate at speeds up to 8 MIPS. Device variants in the PIC12F family have 8 pins, while PIC16F variants are offered in 14-pin through 64-pin packages.

Some variants in the PIC16F family have one or more Enhanced Capture Compare PWM Peripheral (ECCP) modules. The ECCP module is optimized for controlling ½ bridge or H bridge motor drive circuits. It can also be used to steer PWM control signals among 4 output pins for BLDC motor commutation or stepper motor control. The PIC12F and PIC16F device families have these features for low-cost motor control applications:

- Up to 8 MIPS execution speed
- One or more Enhanced Capture Compare PWM (ECCP) modules with dead time control
- Comparator with input multiplexer
- 8-bit or 10-bit ADC (up to 90 ksps)
- Internal RC Oscillator
- Internal 5V Shunt Regulator (on “HV” devices)

## PIC18F Microcontroller Family

The PIC18F product family also has an 8-bit CPU and offers extended performance over the PIC16F device family. The PIC18F device family can operate at speeds up to 16 MIPS and has a hardware multiplier for faster calculation of control algorithms. There are variants in the PIC18F family with specialized motor control peripherals, including a 3-phase motor control PWM peripheral and a quadrature encoder interface (QEI). Other PIC18F variants have the ECCP module found on the PIC16F device family. Source code developed for the PIC16F device family can be easily migrated to the PIC18F family. Devices with the motor control PWM module are well suited for variable speed 3-phase motor applications, while devices with the ECCP module are useful for brush DC and stepper motor applications. The PIC18F family has these features useful for 8-bit motor control applications:

- Up to 16 MIPS execution speed with hardware multiplier
- Motor Control PWM Module with up to 8 outputs
- Motion Control Feedback Module for quadrature encoders
- One or more Enhanced Capture Compare PWM (ECCP) modules
- 10-bit ADC with up to 200 ksps sample rate
- Up to 3 internal comparators

# 16-bit Product Family with Advanced Peripherals

Advanced Motor Control is benefitted by the DSP resources found on the dsPIC® Digital Signal Controllers (DSCs). For example, our sensorless field-oriented control algorithm makes use of the single cycle MAC with data saturation, zero overhead looping and barrel shifting to achieve stunning performance.

## dsPIC® 16-bit Digital Signal Controller Family

- Large family of code and pin-compatible Flash devices
  - The dsPIC30F device family offers 5V or 3.3V operation and are available in 28, 40, 64 and 80-pin packages
  - The dsPIC33F device family provides 3.3V operation and are available in 20, 28, 44, 64, 80 and 100-pin packages
  - Easy to migrate between family members
  - Facilitates low-end to high-end product strategy
  - Flash program memory for faster development cycles and lower inventory cost
- High Speed 16-bit CPU with compiler-efficient architecture
  - 40 MIPS operation dsPIC33F (30 MIPS operation on dsPIC30F)
  - Modified Harvard architecture for simultaneous data and program access
  - 16 x 16-bit general purpose registers for efficient software operations
  - Optimized for C code by design with industry-leading efficiency
- Built-in DSP engine enables high speed and precision PID control loops
  - Full featured DSP engine with two 40-bit accumulators for multi-loop PID control
  - Dual data fetches for single-cycle MAC instruction support
  - Hardware barrel shifter and single-cycle multiplier
  - Saturation support, rounding modes, circular buffer and modulo addressing modes for shorter control loops
- Direct-Memory Access (DMA) (many dsPIC33F devices)
  - Peripherals automatically store/retrieve data from RAM without stealing cycles from the CPU
- Single supply voltage rails eliminate extra voltage regulator circuits
- Precision High Speed Internal Oscillator eliminates external crystal
- Comprehensive System Integration Features
  - Up to 4 Kbytes of Data EEPROM (dsPIC30F) for non-volatile data storage
  - High current sink/source I/O pins: 25 mA/25 mA (dsPIC30F), 4 mA/4 mA (dsPIC33F)
  - Flexible Watchdog Timer (WDT) with on-chip low-power RC oscillator for reliable operation
  - Power-on Reset (POR), Power-up Timer (PWRT) and Oscillator Start-up Timer (OST)
  - Fail-Safe clock monitor operation detects clock failure and switches to on-chip low power RC oscillator (IEC 60730)
  - Programmable code protection
  - In-Circuit Serial Programming™ (ICSP™)
  - Selectable power-saving modes – Sleep, Idle and Alternate Clock modes; Doze mode (dsPIC33F)
  - Programmable Low-Voltage Detection (PLVD) (dsPIC30F)
  - Programmable Brown-out Reset (BOR)
  - Industrial and extended temperature ranges
- MCPWM Module (MC Family)
  - Dedicated time base with up to 8 PWM outputs
  - Up to 4 complementary pairs for 3-phase control
  - Independent output mode for BLDC Control
  - Edge and center-aligned modes for quieter operation
  - Programmable dead-time insertion with separate turn-on and turn-off times
  - Programmable A/D trigger for precise sample timing
  - Up to 2 fault inputs to shutdown PWMs
  - Multiple time bases (i.e., supports motor control and PFC)
- PCPWM Module (GS Family)
  - Up to 18-channels of independent PWMs supporting different duty cycles and frequencies for each PWMH and PWML pair
  - Two Master Time Bases – support multiple 3-phase motors
  - Improved PWM frequency of ~1 MHz at 10-bits of resolution
  - PWM frequency, duty cycle and phase shift resolution of 1 ns
  - PWM modes: edge-aligned, center-aligned, independent, complementary, push-pull, multi-phase, variable phase, current limit and current reset
  - PWM output chopping feature – high frequency clock chops up PWM signal for passage through a pulse transformer
  - Secondary ADC trigger enables two ADC sample requests within a single PWM cycle
  - Leading Edge Blanking (LEB) for internal comparators and/or external inputs to the PWM module to prevent fault signals during noisy MOSFET switching periods
  - PWM time-base capture via an analog comparator or ext. signal
  - More fault and current limit inputs and improved flexibility
- High-speed Analog-to-Digital Converter (ADC)
  - Up to 16 channels, 10-bit resolution, 1.1 Msps (1 μs) high speed conversion rate
  - Up to 4 sample and hold circuits for simultaneous sampling capability for all 3 phases
  - Flexible sampling and conversion modes with 16 result registers
  - Monotonic with no missing codes
- Up to 2 Quadrature Encoder Interfaces (QEI) for shaft encoder inputs
  - Programmable digital noise filters on input pins for robustness against noise
  - Full encoder interface support: A, B, index and up/down
- Up to 4 comparators
  - 20 ns response time for rapid response
  - Programmable voltage reference
- 12-bit A/D converter (up to 0.5 Msps operation)
- Up to eight input capture, output compare, standard PWM channels
- Communication peripherals including UART, SPI, I<sup>2</sup>C™ and CAN

# Advanced Motor Control Applications

## Are you considering moving to brushless motors or sinusoidal control, eliminating costly sensors or adding PFC?

### Sensorless Field Oriented Control (FOC)

Are you looking for top of the line dynamic torque response and efficiency, and the lowest system cost motor control solution?

The dsPIC DSC provides a cost effective and highly efficient solution to this complex algorithm. The fast and accurate on-chip A/D module samples the motor voltage and currents. In software, Clarke and Park transformations transform the A/D information to feed two PI loops controlling torque and flux. Rotor speed and position are determined by an estimator which models the motor. The outputs of the PI loops are transformed using Space Vector Modulation to control the Motor Control PWM Module's PWM outputs. Sinusoidal (180°) outputs provide smoother, quieter motor operation.

### PMSM/BLDC:

- Field weakening runs the motor at several times the rated motor speed
- Adaptive filtering for the estimator reduces the time spent on motor tuning
- PFC brings the voltage and current back into phase, reducing the power required
- Sliding Mode Observer (SMO) or Phase Locked-Loop (PLL) estimator
- Single-Shunt or Dual-Shunt phase current measurement

### ACIM:

- Field weakening runs the motor at several times the rated motor speed
- Phase Locked-Loop (PLL) estimator
- Dual-Shunt phase current measurement

### Digital PFC and Sensorless FOC with Field Weakening

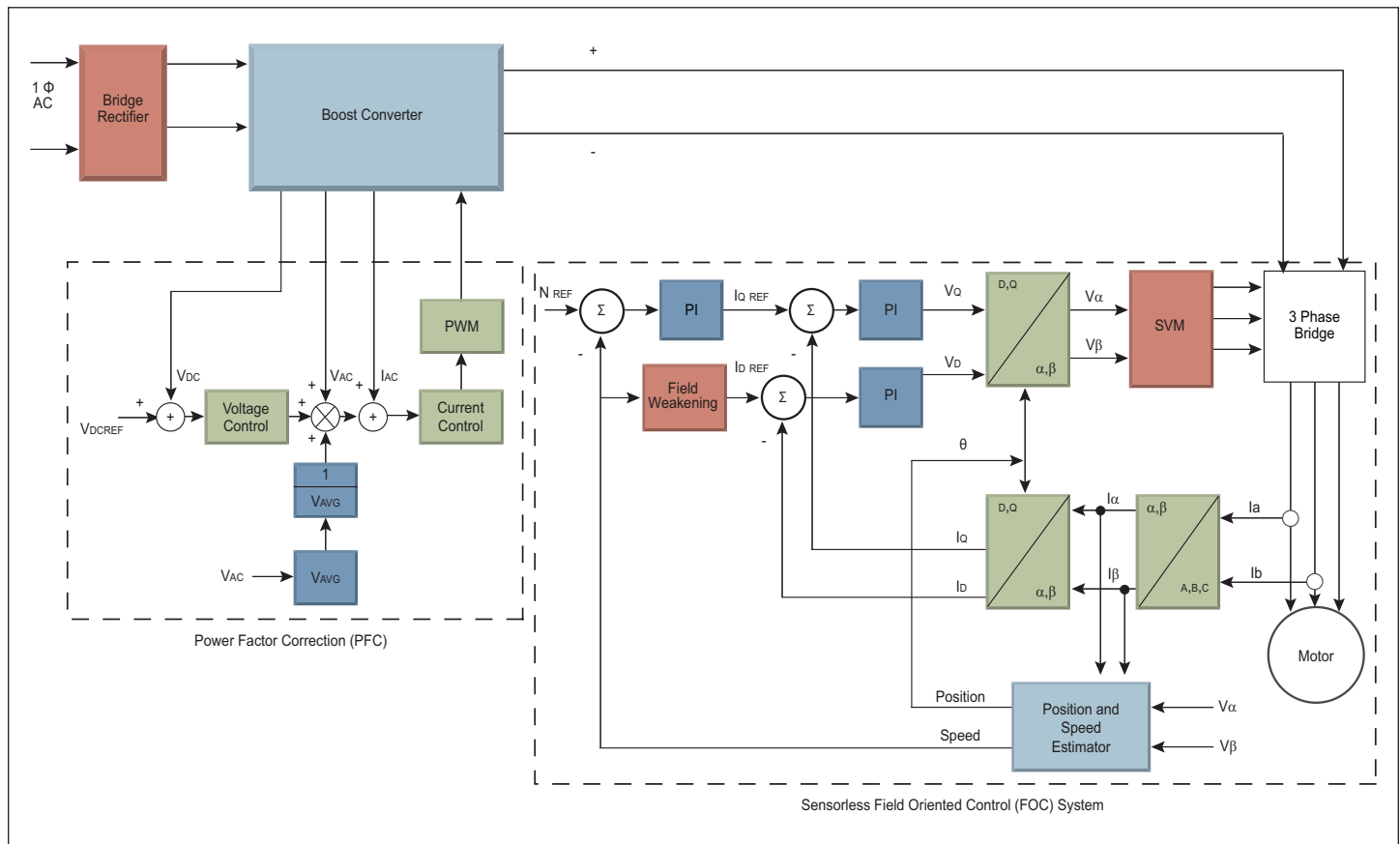

# Advanced Motor Control Applications

## BLDC Sensorless

Want to eliminate your Hall-Effect sensors and cabling cost by going sensorless? PIC16 and PIC18 devices as well as the dsPIC M/C DSCs are made for sensorless BLDC control. The on-chip A/D or comparator sample the motor phase voltages. From the zero-cross, the CPU determines the rotor position and drives the motor control PWM module to generate trapezoidal output signals for the 3-phase inverter circuit.

Take a look at Microchip's sensorless BLDC solutions:

- AN1175 – PIC16F Back EMF with Internal Comparator Zero Cross Detect and Majority Detection
- AN1305 – PIC16F Back EMF with Internal Comparator Zero Cross Detect

## 3-Phase BLDC Using PIC18F on dsPIC DSC with Back EMF

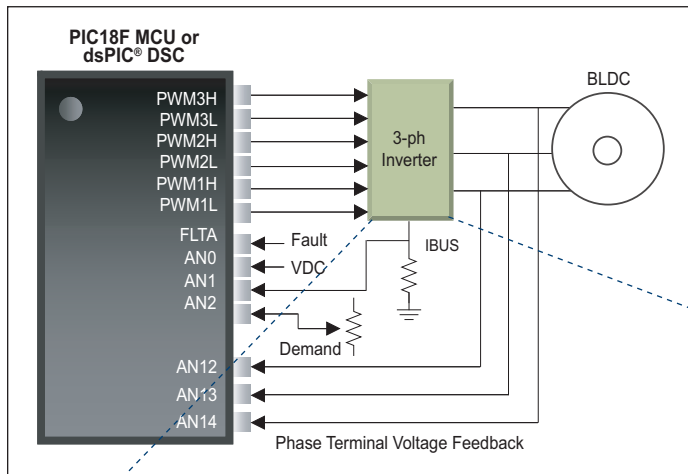

- AN970 – PIC18F2431 Back EMF with External Comparator Zero Cross Detect
- AN901/AN992 – dsPIC30F Back EMF with A/D Zero Cross Detect
- AN1083 – dsPIC33F Filtered Back EMF with A/D Zero Cross Detect
- AN1160 – dsPIC33F Filtered Back EMF with Majority Detect and A/D Zero Cross Detect

FIR filtering of the back EMF helps with high-speed motors or motors with distorted back EMF signals. Majority detect reduces the amount of time spent on motor tuning.

## 3-Phase BLDC Using PIC16F with PWM Output Steering

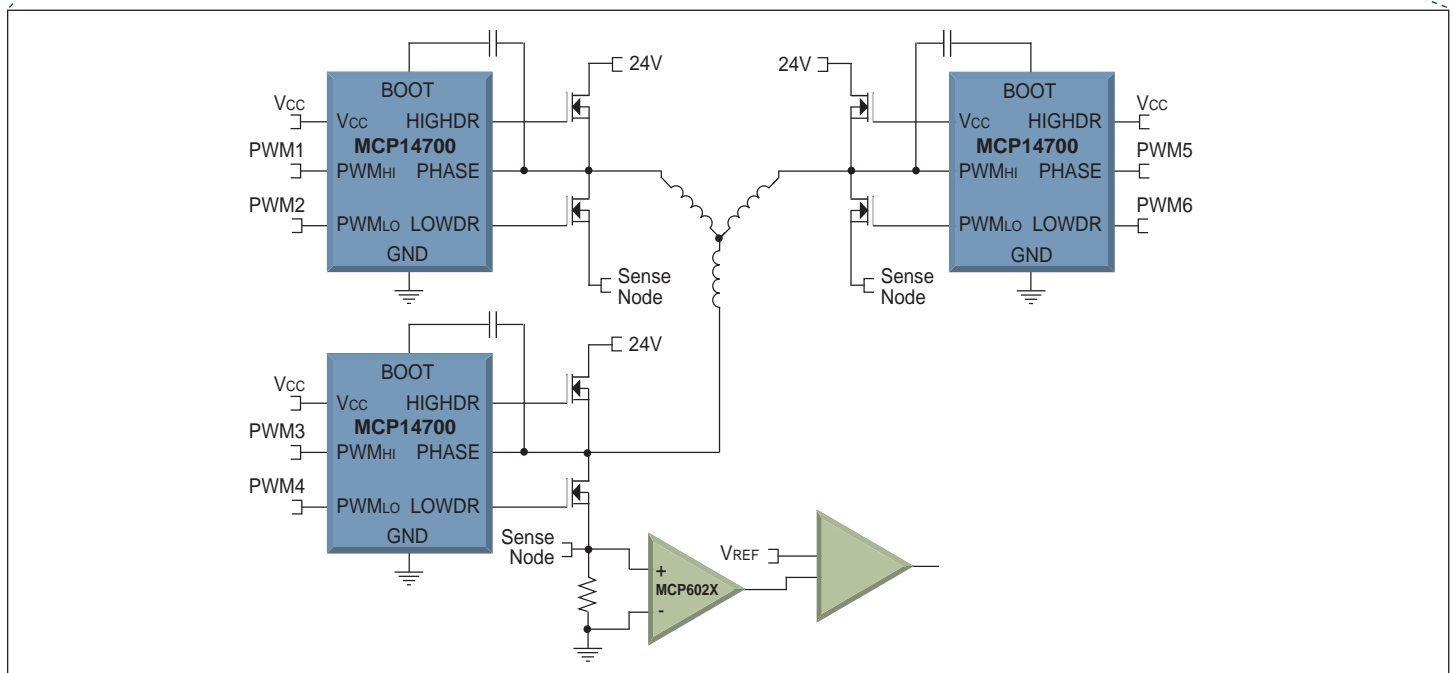
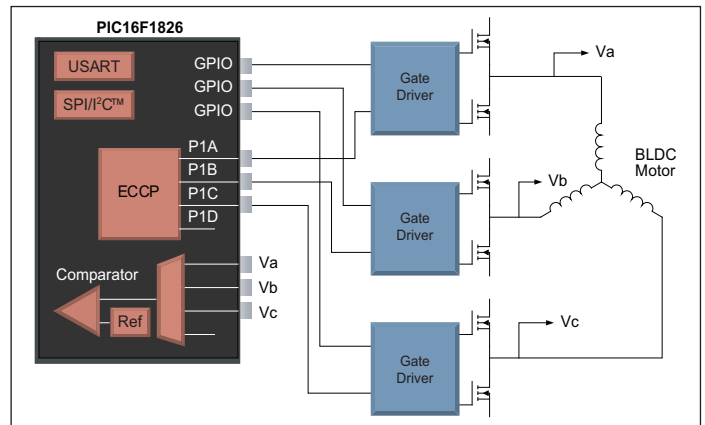

# Advanced Motor Control Applications

## Brushless Fan Control

Need a highly integrated fan controller with a customizable speed/temperature profile? Take a look at Microchip's PIC12HV and PIC16HV devices. These devices have a built-in 5V regulator and on-chip comparator to save system cost. The rotor position is determined by a Hall-Effect sensor connected to the on-chip comparator. The Enhanced Capture Compare PWM (ECCP) Module uses this feedback information to drive the motor by steering the PWM signal to the appropriate motor phase. Temperature sensor inputs can be used to create a unique fan speed profile and the application can provide digital status information to a host device.

### PIC12/16HV615 Integrated Fan Control

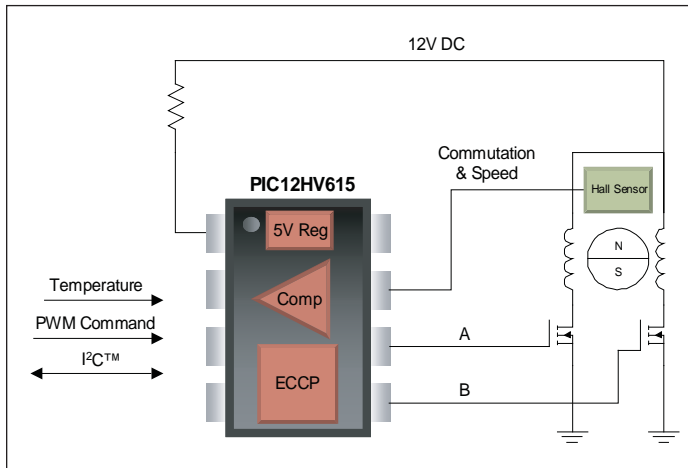

## Stepper Motor Control

Do you need exact position control with great holding torque? If so, then a stepper motor is the best solution. While nearly every MCU or DSC from Microchip can drive a stepper motor, some are better suited than others.

AN906/AN907 – PIC16 Full and Half-Stepping

AN822 – PIC18F Micro-Stepping

AN1307 – dsPIC33F Full, Half and Variable Micro-Stepping with Current Control

### Microstepping Using PIC16F with Hardware Current Control

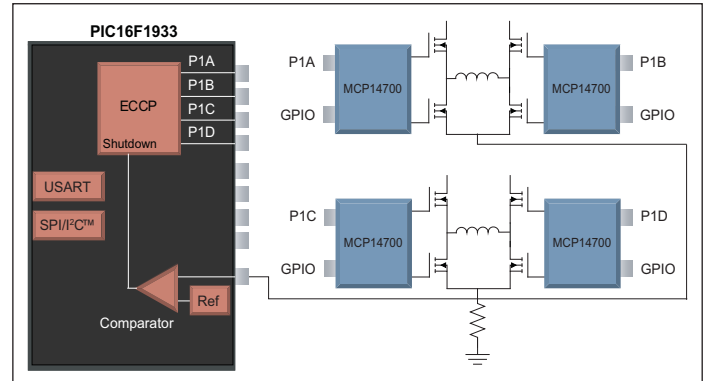

### Microstepping Using dsPIC DSC with Closed-Loop Current Control

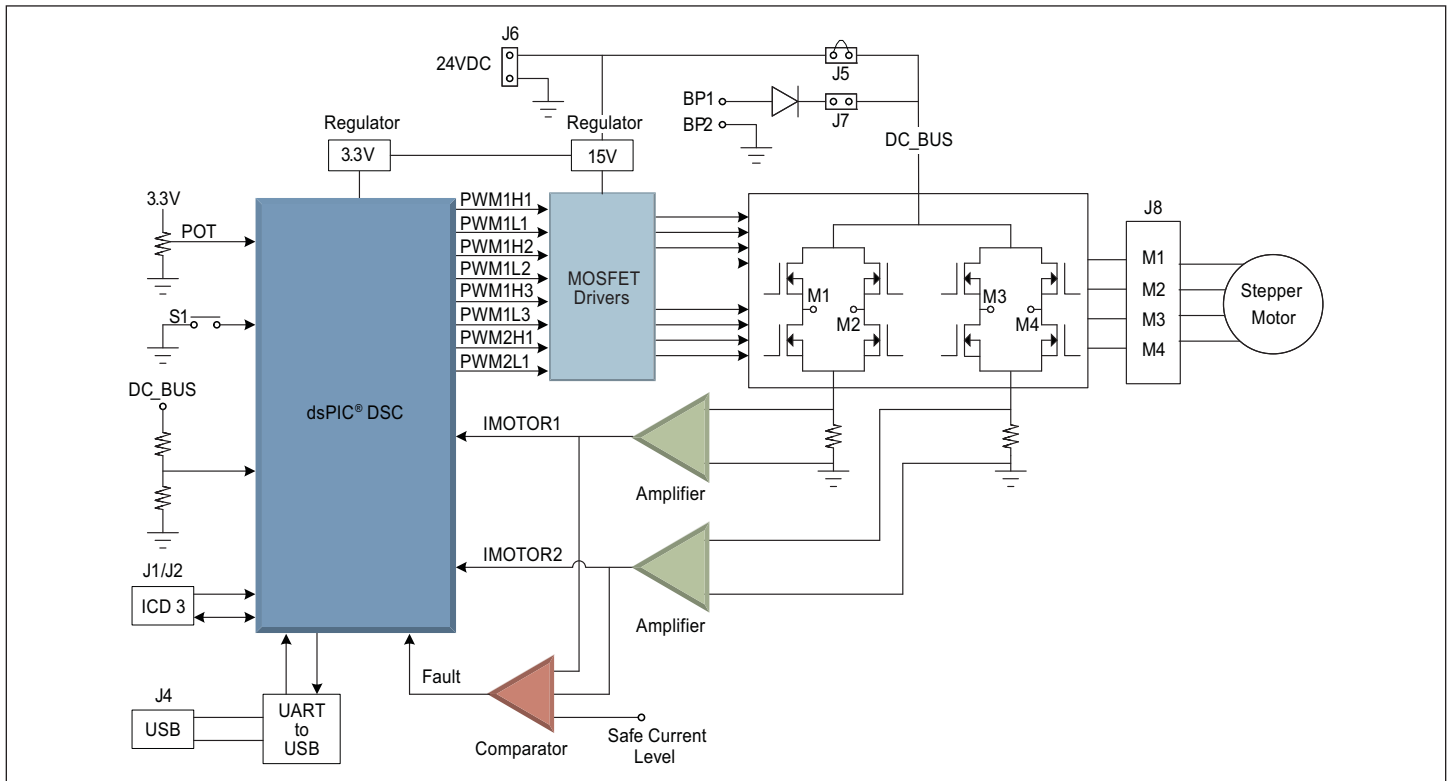

## Motor Control Application Notes by Motor Type

Motor Type	App. Note	Description
Stepper Motor	AN822	Stepper Motor Micro-stepping with PIC18C452
	AN906	Stepper Motor Control Using the PIC16F684
	AN907	Stepper Motor Fundamentals
	AN1307	Stepper Motor Control Using the dsPIC® DSC
Brushed DC Motor	AN696	PIC18CXXX/PIC16CXXX DC Servomotor Applications
	AN893	Low-Cost Bi-directional Brushed DC Motor Control Using the PIC16F684
	AN905	Brushed DC Motor Fundamentals
BLDC and PMSM	AN857	Brushless DC Motor Control Made Easy
	AN885	Brushless DC (BLDC) Motor Fundamentals
	AN899	Brushless DC Motor Control Using PIC18FXX31 MCUs
	AN901	Sensorless Control of BLDC Motor Using dsPIC30F6010
	AN992	Sensorless Control of BLDC Motor Using dsPIC30F2010
	AN957	Sensored Control of BLDC Motor Using dsPIC30F2010
	AN970	Using the PIC18F2431 for Sensorless BLDC Motor Control
	AN1017	Sinusoidal Control of PMSM Motors with dsPIC30F
	AN1078	Dual Shunt Sensorless FOC for PMSM with SMO Estimator and Field Weakening
	AN1083	Sensorless Control of BLDC with Back-EMF Filtering
	AN1160	Sensorless BLDC Control with Back-EMF Filtering Using a Majority Function
	AN1175	Sensorless Brushless DC Motor Control with PIC16
	AN1208	Integrated Power Factor Correction and Sensorless Field-Oriented Control System
	AN1292	Dual Shunt Sensorless FOC for PMSM with PLL Estimator and Field Weakening
	AN1299	Single Shunt Sensorless FOC for PMSM with SMO Estimator and Field Weakening
AC Induction Motor	AN1305	Sensorless 3-Phase Brushless Motor Control with the PIC16FXXX
	AN843	Speed-Control of 3-Phase Induction Motor Using PIC18 Microcontrollers
	AN887	AC Induction Motor Fundamentals
	AN889	VF Control of 3-Phase Induction Motors Using PIC16F7X7 Microcontrollers
	AN900	Controlling 3-Phase AC Induction Motors Using the PIC18F4431
	AN908	Using the dsPIC30F for Vector Control of an ACIM
	AN955	VF Control of 3-Phase Induction Motor Using Space Vector Modulation
	AN967	Bidirectional VF Control of Single and 3-Phase Induction Motor Using Space Vector Modulation
	AN984	Introduction to ACIM Control Using the dsPIC30F
	AN1162	Sensorless Field Oriented Control (FOC) of an ACIM
Other	AN1206	Sensorless Field Oriented Control (FOC) of an ACIM Using Field Weakening
	AN894	Motor Control Sensor Feedback Circuits
	AN898	Determining MOSFET Driver Needs for Motor Drive Applications
	AN1106	Power Factor Correction on dsPIC® DSC
	AN1229	Meeting IEC 60730 Class B Compliance with dsPIC® DSC

## Motor Type/Algorithm Versus MCU Family

Motor Type	Algorithm	PIC16 Family	PIC18 Family	dsPIC® DSC Family
Stepper Motor	Full and Half-Stepping	AN906 AN907		AN1307
	Micro-Stepping		AN822	AN1307
Brushed DC Motor	Unidirectional	AN905		
	Bi-directional	AN893		
	Servo Motor	AN696	AN696	
BLDC and PMSM	Sensored	AN857 AN885	AN899	AN957
	Sensored Sinusoidal			AN1017
	Sensorless BEMF	AN1175 AN1305	AN970	AN901 AN992
	Sensorless Filtered BEMF			AN1083
	Sensorless Filtered BEMF with Majority Detect			AN1160
	Sensorless Dual-Shunt FOC with SMO Estimator and Field Weakening			AN1078
	Sensorless Dual-Shunt FOC with SMO and PFC			AN1208
	Sensorless Dual-Shunt FOC with PLL Estimator and Field Weakening			AN1292
	Sensorless Single-Shunt FOC with SMO Estimator and Field Weakening			AN1299
AC Induction Motor	Open Loop V/F	AN887 AN889 AN955 AN967	AN900 AN843	AN984
	Closed Loop Vector Control			AN908
	Sensorless Dual-Shunt FOC with PLL Estimator			AN1162
	Sensorless Dual-Shunt FOC with PLL Estimator and Field Weakening			AN1206
Other	PFC			AN1106
	Appliance Class B (IEC 60730)		AN1229	AN1229
	Motor Control Sensor Feedback Circuits	AN894	AN894	AN894
	MOSFET Driver Selection	AN898	AN898	AN898



# Product Tables

## Op Amps for Motor Control Applications\*

Device	Op Amps Per Package	GBWP (MHz)	Operating Voltage Range (V)	Rail-to-Rail	Offset Voltage (mV)	Mid-Supply V <sub>REF</sub>	Shutdown Pin
MCP6021/22/23/24	1/2/1/4	10	2.5-5.5	In/Out	0.5	MCP6023	MCP6023
MCP6291/2/3/4	1, 2 or 4	10	2.4-5.5	In/Out	3.0	-	MCP6293

## MOSFET Drivers for Motor Control Applications\*

Device	Package	Configuration	Peak Output Current (A)	Output Resistance (Ohms)	Maximum Supply Voltage (V)
MCP1401/02	SOT23	Single	0.5	5/8	18
MCP1415/16	SOT23	Single	1.5	5/8	18
TC1410/11/12/13	SOIC	Single	0.5-3.0	15/15-2.5/2.5	16
TC4431/2	SOIC	Single	1.5	10/10	30
TC4451/22	SOIC	Single	12/6	2.2	18
TC4467/68/69	SOIC	Quad	1.2	15/15	18
MCP14628	SOIC	Synchronous Buck – Single TTL Input	2	2.5/1	32
MCP14700	SOIC	Synchronous Buck – Dual CMOS Input	2	2.5/1	32

## Fan Managers for Motor Control Applications\*

Device	Description	Typical Accuracy (°C)	Maximum Accuracy @ 25°C (°C)	Maximum Temperature Range (°C)	V <sub>cc</sub> Range (V)	Maximum Supply Current (µA)
TC642	Fan Manager	Note 1	Note 1	-40 to +85	3.0 to 5.5	1,000
TC647B	Fan Manager	Note 1	Note 1	-40 to +85	3.0 to 5.5	400
TC670	Predictive Fan Fault Detector	N/A	N/A	-40 to +85	3.0 to 5.5	150

**Note 1:** These devices use an external temperature sensor. Accuracy of the total solution is a function of the accuracy of the external sensor.

## 8-bit PIC® Microcontrollers for Motor Control Applications\*

Device	Pins	Flash KB	SRAM Bytes	EE Bytes	Timer 8/16-Bit	Comp	CCP/ECCP	Motor Control PWM	A/D 10-Bit	Quad Enc	UART	SPI/I <sup>2</sup> C™
PIC12F615/ PIC16HV615 <sup>(1)</sup>	8	2	64	-	2/1	1	1	-	4 ch	No	-	-
PIC16F616/ PIC16HV616 <sup>(1)</sup>	14	3.5	128	-	2/1	2	0/1	-	8 ch	No	-	-
PIC16F684	14	3.5	128	256	2/1	2	0/1	-	8 ch	No	-	-
PIC16F1823	14	3.5	128	256	2/1	2	0/1	-	8	-	1	1
PIC16F1933	28	7	256	256	4/1	2	2/3	-	11	-	1	1
PIC16F1936	28	14	512	256	4/1	2	2/3	-	11	-	1	1
PIC16F1937	40/44	14	512	256	4/1	2	2/3	-	14	-	1	1
PIC16F1939	40/44	28	1024	256	4/1	2	2/3	-	14	-	1	1
PIC18F45K20	40/44	32	1536	256	1/3	2	1/1	-	14	-	1	1
PIC18F46K20	40/44	64	3936	1024	1/3	2	1/1	-	14	-	1	1
PIC18F1230	18/20	4	256	128	0/2	3	-	6	4 ch	No	1	-
PIC18F1330	18/20	8	256	128	0/2	3	-	6	4 ch	No	1	-
PIC18F2331	28	8	768	256	1/3	-	2	6	5 ch	Yes	1	1
PIC18F2431	28	16	768	256	1/3	-	2	6	5 ch	Yes	1	1
PIC18F4331	40/44	8	768	256	1/3	-	2	8	9 ch	Yes	1	1
PIC18F4431	40/44	16	768	256	1/3	-	2	8	9 ch	Yes	1	1

**Note 1:** HV device has on-chip shunt regulator.

\*These tables represents a sampling of device solutions recommended for motor control design. Microchip's broad portfolio of 8-bit microcontrollers, 16-bit digital signal controllers, analog and interface products, serial EEPROMs and related development systems contains hundreds of products that could potentially be used for motor control design, depending upon the application requirements.

# Product Tables

## dsPIC30F Motor Control and Power Conversion Family

Device	Pins	Flash Memory Kbytes	RAM Bytes	EEPROM Bytes	Timer 16-bit	Input Capture	Output Compare/Standard PWM	Motor Control PWM	Quadrature Encoder	ADC 10-bit 1 Msps	CodeGuard™ Security Segments	UART	SPI	PC™	CAN	Package Code
dsPIC30F2010	28	12	512	1024	3	4	2	6 ch	Yes	6 ch, 4 S/H	1	1	1	1	–	SP, SO, MM
dsPIC30F3010	28/44	24	1024	1024	5	4	2	6 ch	Yes	6 ch, 4 S/H	1	1	1	1	–	SP, SO, 44-pin ML
dsPIC30F4012	28/44	48	2048	1024	5	4	2	6 ch	Yes	6 ch, 4 S/H	1	1	1	1	1	SP, SO, 44-pin ML
dsPIC30F3011	40/44	24	1024	1024	5	4	4	6 ch	Yes	9 ch, 4 S/H	1	2	1	1	–	P, PT, ML
dsPIC30F4011	40/44	48	2048	1024	5	4	4	6 ch	Yes	9 ch, 4 S/H	1	2	1	1	1	P, PT, ML
dsPIC30F5015	64	66	2048	1024	5	4	4	8 ch	Yes	16 ch, 4 S/H	1	1	2	1	1	PT
dsPIC30F6015	64	144	8192	4096	5	8	8	8 ch	Yes	16 ch, 4 S/H	3	2	2	1	1	PT
dsPIC30F5016	80	66	2048	1024	5	4	4	8 ch	Yes	16 ch, 4 S/H	1	1	2	1	1	PT
dsPIC30F6010A	80	144	8192	4096	5	8	8	8 ch	Yes	16 ch, 4 S/H	3	2	2	1	2	PF, PT

## dsPIC33F Motor Control and Power Conversion Family

Device	Pins	Flash KB	RAM KB	DMA # Ch	Timer 16-bit	Input Capture	Output Compare/Standard PWM	Motor Control PWM		QE1	ADC 10-/12-bit+ 1.1/0.5 Msps	16-bit DAC	Analog Comparators	CodeGuard™ Security Segments	UART	SPI	PC™	PMP	RTCC	CAN	Package Code	Temperature Range ***
								MCPWM	PCPWM													
dsPIC33FJ12MC201	20	12	1	–	3	4	2	4+2 ch	–	1	1 ADC, 4 ch	–	–	2	1	1	1	–	–	0	SO, P, SS	I, E
dsPIC33FJ12MC202	28	12	1	–	3	4	2	6+2 ch	–	1	1 ADC, 6 ch	–	–	2	1	1	1	–	–	0	SO, SP, ML	I, E
dsPIC33FJ32MC202	28	32	2	–	3	4	2	6+2 ch	–	1	1 ADC, 6 ch	–	–	2	1	1	1	–	–	0	SO, SP, MM	I, E
dsPIC33FJ32MC302	28	32	4	8	5	4	4	6+2 ch	–	2	1 ADC, 6 ch	–	2	–	2	2	1	1	1	–	SO, SP, MM	I, E, H
dsPIC33FJ64MC202	28	64	8	8	5	4	4	6+2 ch	–	2	1 ADC, 6 ch	–	2	–	2	2	1	1	1	–	SO, SP, MM	I, E, H
dsPIC33FJ64MC802	28	64	16	8	5	4	4	6+2 ch	–	2	1 ADC, 9 ch	–	2	–	2	2	1	1	1	1	SO, SP, MM	I, E, H
dsPIC33FJ128MC202	28	128	8	8	5	4	4	6+2 ch	–	2	1 ADC, 6 ch	–	2	–	2	2	1	1	1	–	SO, SP, MM	I, E, H
dsPIC33FJ128MC802	28	128	16	8	5	4	4	6+2 ch	–	2	1 ADC, 6 ch	–	2	–	2	2	1	1	1	1	SO, SP, MM	I, E, H
dsPIC33FJ16MC304	44	16	2	–	3	4	2	6+2 ch	–	1	1 ADC, 9 ch	–	–	2	1	1	1	–	–	0	PT, ML	I, E, H
dsPIC33FJ32MC204	44	32	2	–	3	4	2	6+2 ch	–	1	1 ADC, 9 ch	–	–	2	1	1	1	–	–	0	PT, ML	I, E, H
dsPIC33FJ32MC304	44	32	4	8	5	4	4	6+2 ch	–	2	1 ADC, 9 ch	–	2	–	2	2	1	1	1	–	PT, ML	I, E, H
dsPIC33FJ64MC204	44	64	8	8	5	4	4	6+2 ch	–	2	1 ADC, 9 ch	–	2	–	2	2	1	1	1	–	PT, ML	I, E, H
dsPIC33FJ64MC804	44	64	16	8	5	4	4	6+2 ch	–	2	1 ADC, 9 ch	2 ch	2	–	2	2	1	1	1	1	PT, ML	I, E, H
dsPIC33FJ128MC204	44	128	8	8	5	4	4	6+2 ch	–	2	1 ADC, 9 ch	–	2	–	2	2	1	1	1	–	PT, ML	I, E, H
dsPIC33FJ128MC804	44	128	16	8	5	4	4	6+2 ch	–	2	1 ADC, 9 ch	2 ch	2	–	2	2	1	1	1	1	PT, ML	I, E, H
dsPIC33FJ32GS406	64	32	4	4	5	4	4	–	12	1	1 ADC, 16 ch	–	–	2	2	2	2	–	–	–	PT, ML	I, E
dsPIC33FJ32GS606	64	32	4	4	5	4	4	–	12	2	2 ADC, 16 ch	4**	4	2	2	2	2	–	–	–	PT, ML	I, E
dsPIC33FJ64GS406	64	64	8	4	5	4	4	–	12	1	1 ADC, 16 ch	–	–	2	2	2	2	–	–	–	PT, ML	I, E
dsPIC33FJ64GS606	64	64	8	4	5	4	4	–	12	2	2 ADC, 16 ch	4**	4	2	2	2	2	–	–	1	PT, ML	I, E
dsPIC33FJ64MC506A	64	64	8	8	9	8	8	8 ch	–	1	1 ADC, 16 ch	–	–	3	2	2	2	–	–	1	PT	I, E
dsPIC33FJ64MC706A	64	64	16	8	9	8	8	8 ch	–	1	2 ADC, 16 ch	–	–	3	2	2	2	–	–	1	PT	I, E
dsPIC33FJ128MC506A	64	128	8	8	9	8	8	8 ch	–	1	1 ADC, 16 ch	–	–	3	2	2	2	–	–	1	PT	I, E
dsPIC33FJ128MC706A	64	128	16	8	9	8	8	8 ch	–	1	2 ADC, 16 ch	–	–	3	2	2	2	–	–	1	PT	I, E

\*dsPIC33 devices feature one or two user-selectable 1.1 Msps 10-bit ADC (4 S&H) or 500 kpsps 12-bit ADC (1 S&H).

\*\*A DAC is associated with each analog comparator to set a programmable voltage reference. One DAC output may be selected by software and driven on an external pin.

\*\*\*I = Industrial Temperature Range (-40°C to +85°C), E = Extended Temperature Range (-40°C to +125°C), H = High Temperature Range (-40°C to +140°C).

# Product Tables

## dsPIC33F Motor Control and Power Conversion Family

Device	Pins	Flash KB	RAM KB	DMA # Ch	Timer 16-bit	Input Capture	Output Compare/ Standard PWM	Motor Control PWM		QEI	ADC 10-/12-bit* 1.1/0.5 Msps	16-bit DAC	Analog Comparators	CodeGuard™ Security Segments	UART	SPI	I <sup>2</sup> C™	PMP	RTCC	CAN	Package Code	Temperature Range***
								MCPWM	PCPWM													
dsPIC33FJ32GS608	80	32	4	4	5	4	4	-	16	2	2 ADC, 18 ch	4**	4	2	2	2	2	-	-	-	PT	I,E
dsPIC33FJ64GS608	80	64	8	4	5	4	4	-	16	2	2 ADC, 18 ch	4**	4	2	2	2	2	-	-	1	PT	I,E
dsPIC33FJ64MC508A	80	64	8	8	9	8	8	8 ch	-	1	1 ADC, 18 ch	-	-	3	2	2	2	-	-	1	PT	I,E,H
dsPIC33FJ128MC708A	80	128	16	8	9	8	8	8 ch	-	1	2 ADC, 18 ch	-	-	3	2	2	2	-	-	2	PT	I,E,H
dsPIC33FJ32GS610	100	32	4	4	5	4	4	-	18	2	2 ADC, 24 ch	4**	4	2	2	2	2	-	-	-	PT, PF	I,E
dsPIC33FJ64GS610	100	64	8	4	5	4	4	-	18	2	2 ADC, 24 ch	4**	4	2	2	2	2	-	-	1	PT, PF	I,E
dsPIC33FJ64MC510A	100	64	8	8	9	8	8	8 ch	-	1	1 ADC, 24 ch	-	-	3	2	2	2	-	-	1	PT, PF	I,E,H
dsPIC33FJ64MC710A	100	64	16	8	9	8	8	8 ch	-	1	2 ADC, 24 ch	-	-	3	2	2	2	-	-	2	PT, PF	I,E,H
dsPIC33FJ128MC510A	100	128	8	8	9	8	8	8 ch	-	1	1 ADC, 24 ch	-	-	3	2	2	2	-	-	1	PT, PF	I,E,H
dsPIC33FJ128MC710A	100	128	16	8	9	8	8	8 ch	-	1	2 ADC, 24 ch	-	-	3	2	2	2	-	-	2	PT, PF	I,E,H
dsPIC33FJ256MC510A	100	256	16	8	9	8	8	8 ch	-	1	1 ADC, 24 ch	-	-	3	2	2	2	-	-	1	PT, PF	I,E
dsPIC33FJ256MC710A	100	256	30	8	9	8	8	8 ch	-	1	2 ADC, 24 ch	-	-	3	2	2	2	-	-	2	PT, PF	I,E,H

\*dsPIC33 devices feature one or two user-selectable 1.1 Msps 10-bit ADC (4 S&H) or 500 ksps 12-bit ADC (1 S&H).

\*\*A DAC is associated with each analog comparator to set a programmable voltage reference. One DAC output may be selected by software and driven on an external pin.

\*\*\*I = Industrial Temperature Range (-40°C to +85°C), E = Extended Temperature Range (-40°C to +125°C), H = High Temperature Range (-40°C to +140°C).

# Development Systems

Microchip offers a number of hardware tools to assist in the development of motor control applications. These tools work with Microchip's MPLAB® IDE and an in-circuit debugger to download and debug application software. Our systems make it easy to customize the software from our application notes and demo code to run different motors.

## **dsPICDEM™ MCSM Development Board (DM330022) \$130**

## **dsPICDEM™ MCSM Stepper Motor Development Board Kit (DV330021) \$270**



This development board is intended for low-voltage (up to 80 volts at 3 amps) 2-phase uni-polar or bi-polar stepper motor (4, 6 or 8 wire) applications. It provides a low-cost system for users to evaluate and develop applications using dsPIC33F motor control DSCs via a Plug-In Module (PIM) or 28-pin SOIC socket. A USB serial interface for RTDM is provided. Feedback support includes current and voltage. Demo software to run motors in open-loop or

closed-loop with full or variable micro-stepping is provided. A DMCI/RTDM GUI for controlling step commands, motor parameter input and operation modes is included. The kit includes a stepper motor and a 24-volt power supply. PICKit™ 3 Debug Express, MPLAB ICD 3 In-Circuit Debugger or REAL ICE™ In-Circuit Emulator is required for programming or debugging operations.

## **dsPICDEM™ MCLV Development Board (DM330021) \$150**



This development board is intended for low-voltage (up to 48 volts at 10 amps) BLDC sensed or sensorless applications. It provides a low-cost system for users to evaluate and develop applications using dsPIC33F

motor control DSCs via a Plug-In Module (PIM) or 28-pin SOIC socket. Serial interfaces include: RS-232C, CAN, LIN and USB (for RTDM). Feedback support includes: Hall-Effect Sensors, Shaft Encoder, Back EMF voltages and single or dual shunt resistors for current. PICKit 3 Debug Express, MPLAB ICD 3 In-Circuit Debugger or REAL ICE In-Circuit Emulator is required for programming or debugging operations.

## **dsPICDEM™ MCHV Development System (DM330023) \$650**



This development system is intended for high-voltage (up to 400 volts at 6.5 amps) BLDC, PMSM and ACIM sensed or sensorless applications. It provides a low-cost Integrated Power Module (IPM) based system for users to evaluate and develop applications

using dsPIC33F motor control DSCs via a Plug-In Module (PIM) or a 28-pin SOIC socket. Isolated serial interfaces include RS-232C and USB (for RTDM). Feedback support includes: Hall-Effect Sensors, Shaft Encoder, Back EMF voltages and single or dual current shunt resistors. A PFC circuit is provided to meet regulatory requirements. An isolated built-in debugger (similar to a starter kit programmer/debugger) permits a direct connection with a PC.

## **PICDEM™ MC LV Motor Control Development Board (DM183021) \$130**



The PICDEM MC LV development board is intended for low-voltage (up to 48V at 2 Amps), Brushless DC (BLDC) sensed or sensorless applications. It provides a low-cost board for users to evaluate and develop applications using Microchip's

28-pin PIC18FXX31 and dsPIC30F motor control devices. An 18-pin translator board (AC162078) is also available and allows the PIC18F1330 to be installed on the board. Feedback support includes Hall-Effect Sensors and Back EMF voltages. MPLAB ICD 3 In-Circuit Debugger or REAL ICE In-Circuit Emulator is required for programming or debugging operations.

# dsPIC30F Motor Control Development Systems

This modular full-featured system provides a method for users to evaluate and develop applications using dsPIC30F motor control DSCs via a Plug-In-Module (PIM). The MC1 includes a dsPIC30F6010A PIM. The MC1H provides isolated user interfaces for safe operation. MPLAB® ICD 3 In-Circuit Debugger or REAL ICE™ In-Circuit Emulator is required for programming or debugging operations.



A 3-phase High Voltage Power Module and MC1 Motor Control Development Board are shown.

DSC Family	Input Voltage	Development Board	Power Module	Motor
dsPIC30F	≤ 48 volts DC, 600W	dsPICDEM™ MC1 (DM300020) \$300	dsPICDEM MC1L 3-Phase Low Voltage Power Module (DM300022) \$700	AC300020 \$120 or AC300022 \$160
dsPIC30F	≤ 240 volts AC, 800W	dsPICDEM MC1 (DM300020) \$300	dsPICDEM MC1H 3-Phase High Voltage Power Module (DM300021) \$800	AC300021 \$120

## Motors

You can provide your own motor or purchase one of the motors used in our application notes and guaranteed to run, right out of the box:

- AC300024 – 2-phase, 8-wire stepper motor, \$90
- AC300020 – 24V BLDC motor, \$120
- AC300022 – 24V BLDC motor with shaft encoder, \$160
- AC300021 – 208V, 1/3 HP 3-phase AC induction motor, \$120



# Motor Control Tuning GUIs

These software plug-in tools included with MPLAB® IDE assist with the development of motor control applications:

- **AN901 BLDC Tuning Interface** – Provides a graphical method to configure the motor parameters associated with the AN901 application.
- **AN908 ACIM Tuning Interface** – Provides a graphical method to adjust the control loop parameters associated with the AN908 application.

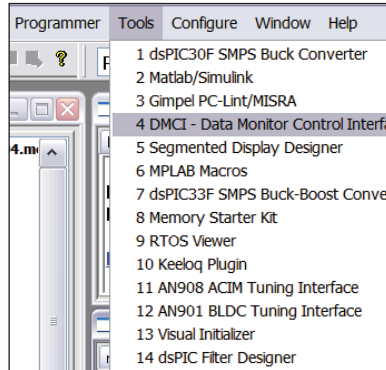

- **Data Monitor and Control Interface (DMCI)** – Provides a customizable GUI to input and adjust software motor parameters using sliders and switches. Four customizable output plots can be used to show a graphical history of control variables so that the motor dynamic response can be analyzed. This tool is useful for tweaking software parameters and visualizing historical data during debug sessions. Most motor control application note software comes with a setup file to automatically configure DMCI for the application.

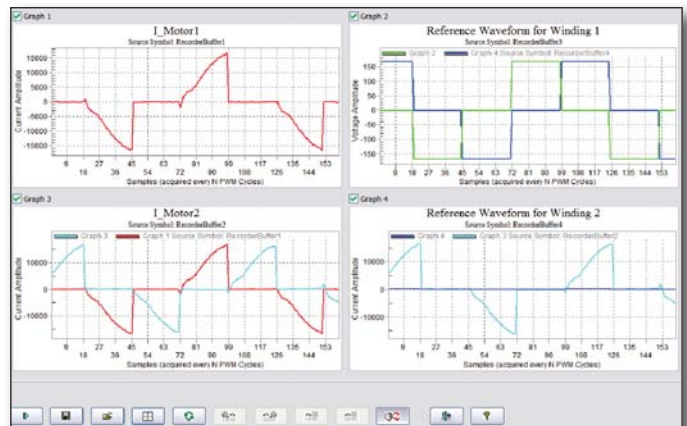
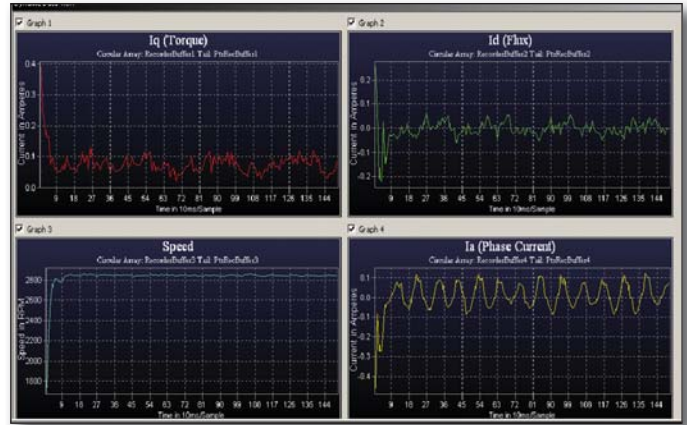
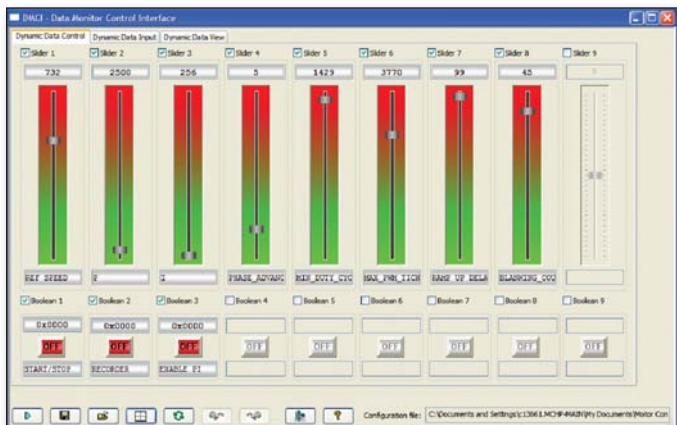
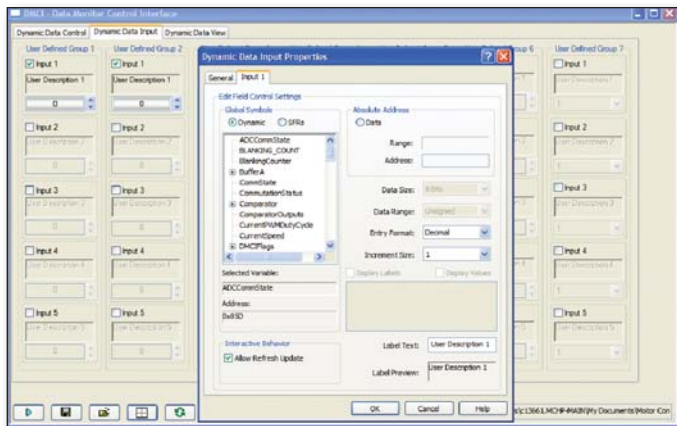

- **Real-Time Data Monitor (RTDM)** – Make a change to a software parameter and see the effect immediately without stopping the motor. A serial USB or UART cable supports bi-directional data transfers between the host PC and the MCU/DSC. This is configured within DMCI and most motor control application note software comes with a setup file to automatically configure RTDM for the application.

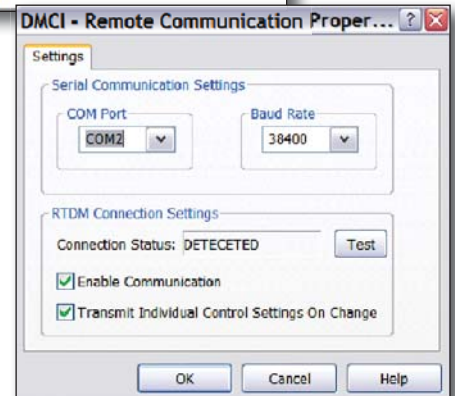
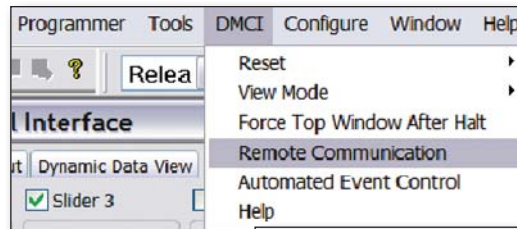

# Training Solutions

Microchip provides a variety of ways to come up to speed quickly on our 8-bit MCU's and 16-bit dsPIC® DSCs, as well as learn how to use them to spin a motor.

Pressed for time? Log on to [www.microchip.com/webseminars](http://www.microchip.com/webseminars) and download a web seminar on your own schedule. These training modules are just the right size to fit into your busy schedule.

Filters (Optional):		Language	English		
		Category	Motor Control		
	Title	Language	Recording Date	Duration	
<a href="#">Details</a>	Brushed DC Motor Basics	English	09/18/2008	14 min	
<a href="#">Details</a>	Sensorless BLDC motor control using a Majority Function	English	04/29/2008	19 min	
<a href="#">Details</a>	Sensorless Field Oriented (FOC) Control for AC Induction Motors	English	01/21/2008	23 min	
<a href="#">Details</a>	Sensorless Field Oriented (FOC) Control for AC Induction Motors	English	01/21/2008	23 min	
<a href="#">Details</a>	Stepper Motors Part 1: Types of Stepper Motors	English	09/14/2007	19 min	
<a href="#">Details</a>	Stepper Motors Part 2: Stepper Motor Control	English	09/14/2007	17 min	
<a href="#">Details</a>	Sensorless Field Oriented Control for Permanent Magnet Synchronous Motors	English	03/30/2007	30 min	
<a href="#">Details</a>	Sensorless Field Oriented Control for Permanent Magnet Synchronous Motors	English	03/30/2007	30 min	
<a href="#">Details</a>	dsPIC30F Quadrature Encoder Interface Module	English	03/30/2005	20 min	
<a href="#">Details</a>	dsPIC30F Motor Control PWM Module	English	03/30/2005	20 min	

## Want to Learn From an Expert?

Log on to [www.microchip.com/RTC](http://www.microchip.com/RTC) and sign up for a formal class taught by a Microchip engineer. Many of these classes include hands on motor control development work, so you can learn the theory and then put it into practice. Additional classes are available that cover the device programming and peripheral usage, C language and control techniques that are not specific to motor control.

Class	Hours	Hands On	Abstract
<b>IMC1253: Overview of Intelligent Motor Control</b>	2	No	This class reviews common motor types, control algorithms and motor interface design. It serves as a broad introduction to Microchip's motor control portfolio.
<b>MCT0301: BLDC Motor Control Workshop Using dsPIC® DSCs</b>	7	Yes	This class presents an in-depth analysis of Microchip's BLDC Motor Control algorithms. The class also provides an overview of the dsPIC DSC's motor control peripherals. Attendees will use the DMCI to modify algorithms and control the motor.
<b>MCT3101: BLDC Control Techniques</b>	7	Yes	This class presents an in-depth analysis of Microchip's BLDC Motor Control algorithms. The class also provides an overview of the dsPIC DSC's motor control peripherals. Attendees will use the DMCI to modify algorithms and control the motor. Sensorless, sensorless and field oriented control are all covered.
<b>MCT7101: Sensorless Field Oriented Control for PMSM Motors</b>	6	Yes	This class will guide the attendee through PMSM motor construction and its control. By the use of practical exercises, attendees will get familiar with Microchip tools and an advance algorithm for PMSM: Sensorless FOC for PMSM. It will be a 4 hour presentation, with hands on exercises using Microchip development tools. Attendees should have basic understanding of motor control fundamentals.

## Need Design Assistance?

Visit [www.microchip.com/partners](http://www.microchip.com/partners) for a directory of third party consultants and designers that can help with your motor control application.

## Get Started Now!

Microchip makes it easy to add electronic motor control functionality to your embedded design. For access to Microchip's complete motor control design resources, visit the Motor Control Design Center at [www.microchip.com/motor](http://www.microchip.com/motor) or [www.microchip.com/dscmotor](http://www.microchip.com/dscmotor). Whether you are a motor control expert or a beginner, these dedicated sites contain links to everything you need to complete your motor control design from datasheets and samples to application notes with source code and development boards.

## Support

Microchip is committed to supporting its customers in developing products faster and more efficiently. We maintain a worldwide network of field applications engineers and technical support ready to provide product and system assistance. In addition, the following service areas are available at [www.microchip.com](http://www.microchip.com):

- **Support** link provides a way to get questions answered fast: <http://support.microchip.com>
- **Sample** link offers evaluation samples of any Microchip device: <http://sample.microchip.com>
- **Forum** link provides access to knowledge base and peer help: <http://forum.microchip.com>
- **Buy** link provides locations of Microchip Sales Channel Partners: [www.microchip.com/sales](http://www.microchip.com/sales)

## Sales Office Listing

### AMERICAS

#### Atlanta

Tel: 678-957-9614

#### Boston

Tel: 774-760-0087

#### Chicago

Tel: 630-285-0071

#### Cleveland

Tel: 216-447-0464

#### Dallas

Tel: 972-818-7423

#### Detroit

Tel: 248-538-2250

#### Kokomo

Tel: 765-864-8360

#### Los Angeles

Tel: 949-462-9523

#### Santa Clara

Tel: 408-961-6444

#### Toronto

Mississauga, Ontario

Tel: 905-673-0699

### EUROPE

#### Austria - Wels

Tel: 43-7242-2244-39

#### Denmark - Copenhagen

Tel: 45-4450-2828

#### France - Paris

Tel: 33-1-69-53-63-20

#### Germany - Munich

Tel: 49-89-627-144-0

#### Italy - Milan

Tel: 39-0331-742611

#### Netherlands - Drunen

Tel: 31-416-690399

#### Spain - Madrid

Tel: 34-91-708-08-90

#### UK - Wokingham

Tel: 44-118-921-5869

## Training

If additional training interests you, then Microchip can help. We continue to expand our technical training options, offering a growing list of courses and in-depth curriculum locally, as well as significant online resources – whenever you want to use them.

- Regional Training Centers: [www.microchip.com/rtc](http://www.microchip.com/rtc)
- MASTERS Conferences: [www.microchip.com/masters](http://www.microchip.com/masters)
- Worldwide Seminars: [www.microchip.com/seminars](http://www.microchip.com/seminars)
- eLearning: [www.microchip.com/webseminars](http://www.microchip.com/webseminars)
- Resources from our Distribution and Third Party Partners [www.microchip.com/training](http://www.microchip.com/training)

### ASIA/PACIFIC

#### Australia - Sydney

Tel: 61-2-9868-6733

#### China - Beijing

Tel: 86-10-8528-2100

#### China - Chengdu

Tel: 86-28-8665-5511

#### China - Hong Kong SAR

Tel: 852-2401-1200

#### China - Nanjing

Tel: 86-25-8473-2460

#### China - Qingdao

Tel: 86-532-8502-7355

#### China - Shanghai

Tel: 86-21-5407-5533

#### China - Shenyang

Tel: 86-24-2334-2829

#### China - Shenzhen

Tel: 86-755-8203-2660

#### China - Wuhan

Tel: 86-27-5980-5300

#### China - Xiamen

Tel: 86-592-2388138

#### China - Xian

Tel: 86-29-8833-7252

#### China - Zhuhai

Tel: 86-756-3210040

### ASIA/PACIFIC

#### India - Bangalore

Tel: 91-80-3090-4444

#### India - New Delhi

Tel: 91-11-4160-8631

#### India - Pune

Tel: 91-20-2566-1512

#### Japan - Yokohama

Tel: 81-45-471- 6166

#### Korea - Daegu

Tel: 82-53-744-4301

#### Korea - Seoul

Tel: 82-2-554-7200

#### Malaysia - Kuala Lumpur

Tel: 60-3-6201-9857

#### Malaysia - Penang

Tel: 60-4-227-8870

#### Philippines - Manila

Tel: 63-2-634-9065

#### Singapore

Tel: 65-6334-8870

#### Taiwan - Hsin Chu

Tel: 886-3-572-9526

#### Taiwan - Kaohsiung

Tel: 886-7-536-4818

#### Taiwan - Taipei

Tel: 886-2-2500-6610

#### Thailand - Bangkok

Tel: 66-2-694-1351

1/26/09

Microcontrollers • Digital Signal Controllers • Analog • Serial EEPROMs

Information subject to change. The Microchip name and logo, the Microchip logo, dsPIC, MPLAB and PIC are registered trademarks of Microchip Technology Incorporated in the U.S.A. and other countries. CodeGuard, dsPICDEM, In-Circuit Serial Programming, ICSP, PICDEM and PICtail are trademarks of Microchip Technology Incorporated in the U.S.A. and other countries. All other trademarks mentioned herein are property of their respective companies. © 2009, Microchip Technology Incorporated. All Rights Reserved.

Printed in the U.S.A. 12/09  
DS00896G



**MICROCHIP**  
[www.microchip.com](http://www.microchip.com)

Microchip Technology Inc.  
2355 W. Chandler Blvd.  
Chandler, AZ 85224-6199