

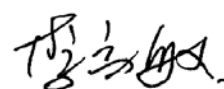
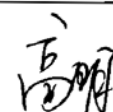

# Product Specification

**Product Name: VGM096032A3W03**

**Product Code: M01633**

<b>Customer</b>
<b>Approved by Customer</b>
<b>Approved Date:</b>

Designed By	Checked By	Approved By	
		R&D	QA
 2015.4.8	 2015.4.11	 2015.4.10	 4/10.15

---

## CONTENT

<b>REVISION RECORD</b> .....	<b>3</b>
<b>1 OVERVIEW</b> .....	<b>4</b>
<b>2 FEATURES</b> .....	<b>4</b>
<b>3 MECHANICAL DATA</b> .....	<b>4</b>
<b>4 MECHANICAL DRAWING</b> .....	<b>5</b>
<b>5 MODULE INTERFACE</b> .....	<b>6</b>
<b>6 FUNCTION BLOCK DIAGRAM</b> .....	<b>7</b>
<b>7 ABSOLUTE MAXIMUM RATINGS</b> .....	<b>8</b>
<b>8 ELECTRICAL CHARACTERISTICS</b> .....	<b>8</b>
8.1 DC ELECTRICAL CHARACTERISTICS .....	8
8.2 ELECTRO-OPTICAL CHARACTERISTICS .....	9
8.3 AC ELECTRICAL CHARACTERISTICS .....	10
<b>9 FUNCTIONAL SPECIFICATION AND APPLICATION CIRCUIT</b> .....	<b>11</b>
9.1 POWER ON AND POWER OFF SEQUENCE WITH EXTERNAL VCC.....	11
9.3 APPLICATION CIRCUIT.....	13
9.4 EXTERNAL DC-DC APPLICATION CIRCUIT .....	15
9.5 DISPLAY CONTROL INSTRUCTION.....	16
9.6 RECOMMENDED SOFTWARE INITIALIZATION .....	16
<b>10 PACKAGE SPECIFICATION</b> .....	<b>17</b>
<b>11 RELIABILITY</b> .....	<b>18</b>
11.1 RELIABILITY TEST.....	18
11.2 LIFETIME.....	18
11.3 FAILURE CHECK STANDARD.....	18
<b>11 ILLUSTRATION OF OLED PRODUCT NAME</b> .....	<b>19</b>
<b>12 OUTGOING QUALITY CONTROL SPECIFICATIONS</b> .....	<b>20</b>
12.1 SAMPLING METHOD .....	20
12.2 INSPECTION CONDITIONS .....	20
12.3 QUALITY ASSURANCE ZONES.....	20
12.4 INSPECTION STANDARD.....	21
<b>13 PRECAUTIONS FOR OPERATION AND STORAGE</b> .....	<b>24</b>
13.1 PRECAUTIONS FOR OPERATION .....	24
13.2 SOLDERING .....	24
13.3 PRECAUTIONS FOR STORAGE.....	24
13.4 WARRANTY PERIOD.....	24

**REVISION RECORD**

REV.	REVISION DESCRIPTION	REV. DATE	REMARK
D01	Initial Release	2015-02-09	

## 1 Overview

VGM096032A3W03 is a monochrome OLED display module with 96×32 dot matrix. The characteristics of this display module are high brightness, self-emission, high contrast ratio, slim/thin outline, wide viewing angle, wide temperature range, and low power consumption.

## 2 Features

- Display Color: White
- Dot Matrix: 96×32
- Driver IC: SSD1316
- Interface: I<sup>2</sup>C
- Wide range of operating temperature: -40°C to 70°C

## 3 Mechanical Data

NO.	ITEM	SPECIFICATION	UNIT
1	Dot Matrix	96(W)×32(H)	-
2	Dot Size	0.2(W)×0.17(H)	mm <sup>2</sup>
3	Dot Pitch	0.22(W)×0.19(H)	mm <sup>2</sup>
4	Aperture Rate	81	%
5	Active Area	21.1 (W)×6.06 (H)	mm <sup>2</sup>
6	Panel Size	29.1(W)×9.2(H) ×1.05(T)	mm <sup>3</sup>
7	Module Size	47.1(W)×9.2(H) ×1.05(T)	mm <sup>3</sup>
8	Diagonal A/A Size	0.86	inch
9	Module Weight	0.70±10%	gram

### 4 Mechanical Drawing

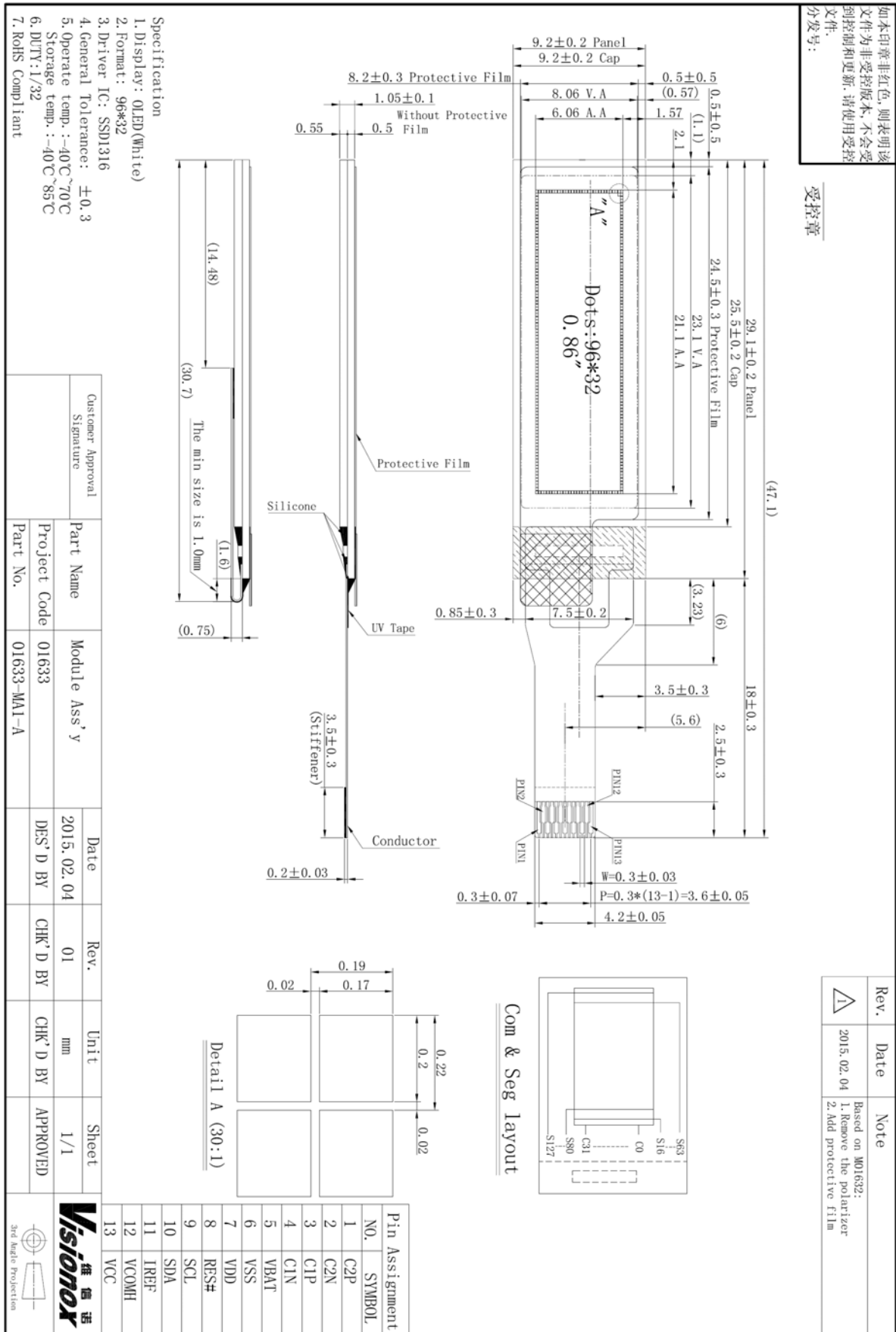

## 5 Module Interface

PIN NO.	PIN NAME	DESCRIPTION
1	C2P	C1P/C1N – Pin for charge pump capacitor; Connect to each other with a capacitor. C2P/C2N – Pin for charge pump capacitor; Connect to each other with a capacitor.
2	C2N	
3	C1P	
4	C1N	
5	VBAT	Power supply for charge pump regulator circuit. Table 5.1
6	VSS	This is a ground pin.
7	VDD	Power supply pin for core logic operation.
8	RES#	This pin is reset signal input. When the pin is LOW, initialization of the chip is executed.
9	SCL	Serve clock pin.
10	SDA	Serve data pin.
11	IREF	This pin is segment current reference pin. A resistor should be connected between this pin and VSS.
12	VCOMH	This pin is the input pin for the voltage output high level for COM signals. A capacitor should be connected between this pin and VSS.
13	VCC	Power supply for panel driving voltage. This is also the most positive power voltage supply pin. When charge pump is enabled, a capacitor should be connected between this pin and VSS.

**Table 5.1**

Status	VBAT	VDD	VCC
Enable charge pump	Connect to external VBAT source	Connect to external VDD source	A capacitor should be connected between this pin and VSS
Disable charge pump	Keep float	Connect to external VDD source	Connect to external VCC source

## 6 Function Block Diagram

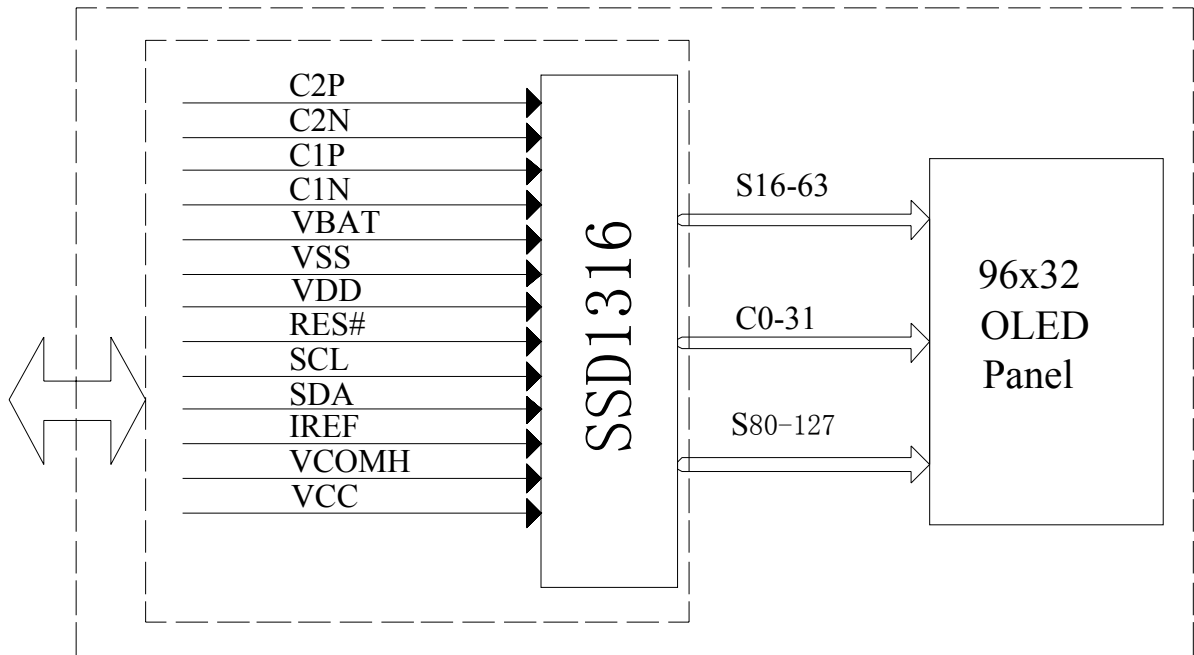

## 7 Absolute Maximum Ratings

ITEM	SYMBOL	MIN	MAX	UNIT	REMARK
Supply Voltage	VDD	-0.3	4.0	V	IC maximum rating
	VBAT	-0.3	5.0	V	IC maximum rating
OLED Operating Voltage	VCC	0	16	V	IC maximum rating
Operating Temp.	Top	-40	70	°C	-
Storage Temp	Tstg	-40	85	°C	-

Note (1): All of the voltages are on the basis of “VSS = 0V”.

Note (2): Permanent breakage of module may occur if the module is used beyond the maximum rating. The module can be normal operated under the conditions according to Section 8 “Electrical Characteristics”.

Malfunctioning of the module may occur and the reliability of the module may deteriorate if the module is used beyond the conditions.

## 8 Electrical Characteristics

### 8.1 DC Electrical Characteristics

ITEM	SYMBOL	TEST CONDITION	MIN	TYP.	MAX	UNIT
Logic Supply Voltage	VDD	22±3°C, 55±15%R.H	1.65	2.8	3.3	V
Supply Voltage for DC/DC	VBAT	22±3°C, 55±15%R.H	3.0	3.7	4.2	
OLED Driver Supply Voltage (Generated by Internal DC/DC)	VCC	22±3°C, 55±15%R.H	-	9.0	-	V
High-level Input Voltage	V <sub>IH</sub>	-	0.8×VDD	-	-	V
Low-level Input Voltage	V <sub>IL</sub>	-	-	-	0.2×VDD	V
High-level Output Voltage	V <sub>OH</sub>	-	0.9×VDD	-	-	V
Low-level Output Voltage	V <sub>OL</sub>	-	-	-	0.1×VDD	V

Note : The VCC input must be kept in a stable value; ripple and noise are not allowed.



## 8.2 Electro-optical Characteristics

ITEM	SYMBOL	TEST CONDITION	MIN	TYP.	MAX	UNIT
Normal Mode Brightness	$L_{br}$	All pixels ON(1) (VCC generated by internal DC/DC)	380	480	-	cd/m <sup>2</sup>
ICC,Sleep mode Current	ICC,SLEEP	VDD=1.65V~3.3V,VCC=7~15V Display OFF,No panel attached	-	-	20	uA
IDD,Sleep mode Current	IDD,SLEEP	VDD=1.65V~3.3V,VCC=7~15V Display OFF,No panel attached	-	-	20	uA
Normal Mode Power Consumption (VCC Generated by Internal DC/DC)	$P_t=(I_{BAT} \times V_{BAT})$	All pixels ON(1) (VCC generated by internal DC/DC)	-	79.55	96.2	mW
C.I.E(White)	(x)	x,y(CIE1931)	0.26	0.30	0.34	-
	(y)		0.29	0.33	0.37	-
Dark Room Contrast	CR	-	≥2000: 1	-	-	-
Response Time	-	-	---	10	-	μs
View Angle	-	-	≥160	-	-	Degree

Note(1): Normal Mode test conditions are as follows:

- Driving voltage : 9.0V(VCC Supplied Externally) or VBAT:3.7V(VCC Generated by Internal DC/DC).
- Frame rate : 115Hz
- Contrast setting : 0x75
- Duty setting : 1/32

### 8.3 AC Electrical Characteristics

#### I<sup>2</sup>C Interface Timing Characteristics

(VDD - VSS = 1.65V to 3.3V, TA = 25°C)

Symbol	Parameter	Min	Typ	Max	Unit
$t_{\text{cycle}}$	Clock Cycle Time	2.5	-	-	us
$t_{\text{HSTART}}$	Start condition Hold Time	0.6	-	-	us
$t_{\text{HD}}$	Data Hold Time (for “SDA <sub>OUT</sub> ” pin)	0	-	-	ns
	Data Hold Time (for “SDA <sub>IN</sub> ” pin)	300	-	-	ns
$t_{\text{SD}}$	Data Setup Time	100	-	-	ns
$t_{\text{SSTART}}$	Start condition Setup Time (Only relevant for a repeated Start condition)	0.6	-	-	us
$t_{\text{SSTOP}}$	Stop condition Setup Time	0.6	-	-	us
$t_{\text{R}}$	Rise Time for data and clock pin	-	-	300	ns
$t_{\text{F}}$	Fall Time for data and clock pin	-	-	300	ns
$t_{\text{IDLE}}$	Idle Time before a new transmission can start	1.3	-	-	us

I<sup>2</sup>C interface characteristics

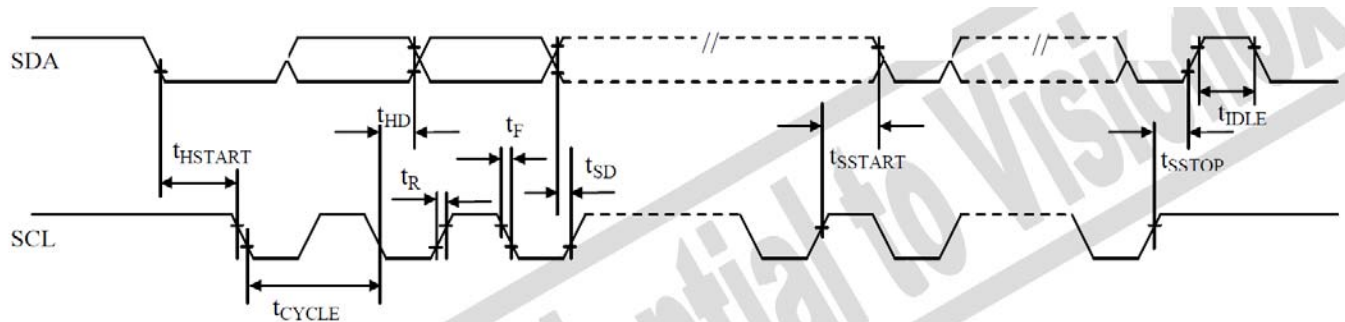

## 9 Functional Specification and Application Circuit

### 9.1 Power ON and Power OFF Sequence with External VCC

#### Power ON Sequence:

1. Power ON VDD
2. After VDD become stable, set RES# pin LOW (logic low) for at least 3us ( $t_1$ )<sup>(4)</sup> and then HIGH (logic high).
3. After set RES# pin LOW (logic low), wait for at least 3us ( $t_2$ ). Then Power ON VCC<sup>(1)</sup>.
4. After VCC become stable, send command AFh for display ON. SEG/COM will be ON after 100ms ( $t_{AF}$ ).

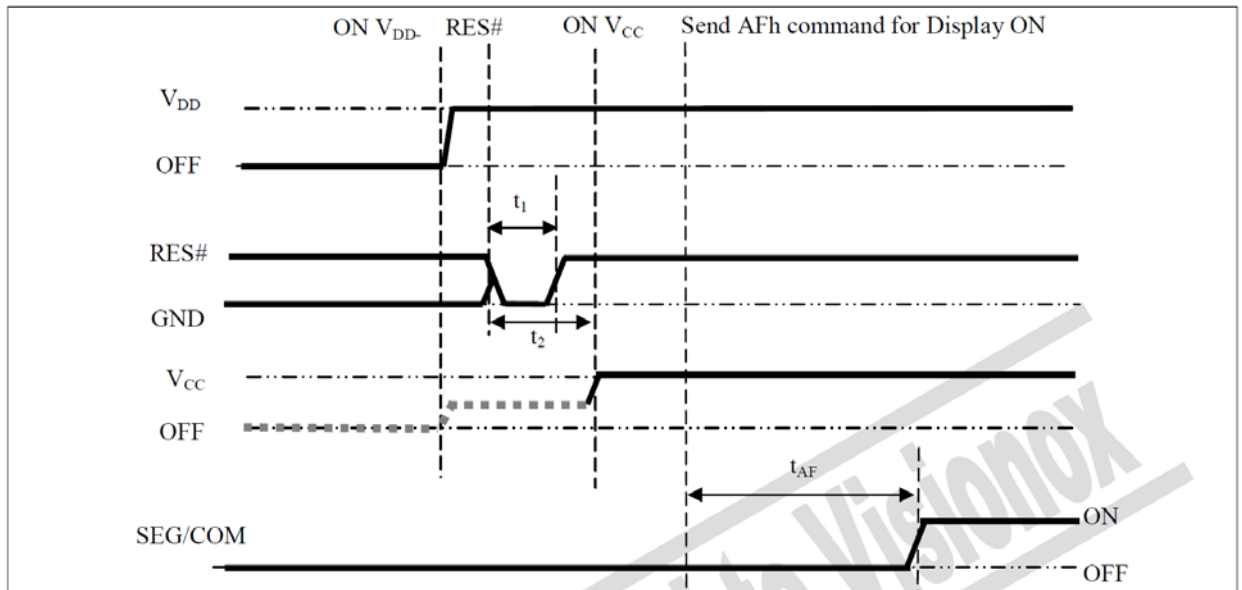

#### Power OFF Sequence:

1. Send command AEh for display OFF.
2. Power OFF VCC<sup>(1)(2)(3)</sup>.
3. Power OFF VDD after  $t_{OFF}$ .<sup>(5)</sup> (Typical  $t_{OFF}$ =100ms)

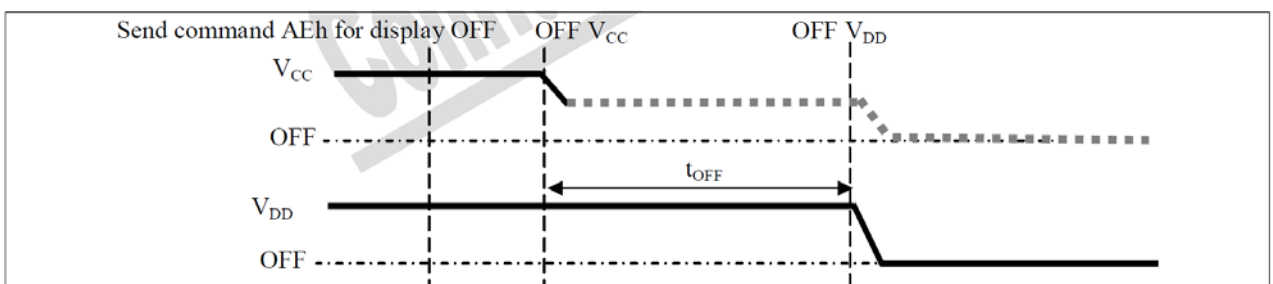

#### Note:

- (1) Since an ESD protection circuit is connected between VDD and VCC, VCC becomes lower than VDD whenever VDD is ON and VCC is OFF as shown in the dotted line of VCC in above figures.
- (2) VCC should be kept float (disable) when it is OFF.
- (3) Power Pins(VDD, VCC) can never be pulled to ground under any circumstance.
- (4) The register values are reset after  $t_1$ .
- (5) VDD should not be Power OFF before VCC Power OFF.

### 9.2 Power ON and OFF sequence with Charge Pump Application

#### Power ON sequence:

1. Power ON VDD
2. Wait for  $t_{ON}$ . Power ON VBAT.<sup>(1),(2)</sup> (where Minimum  $t_{ON} = 0ms$ )
3. After VBAT become stable, set RES# pin LOW (logic low) for at least 3us ( $t_1$ )<sup>(3)</sup> and then HIGH (logic high).
4. After set RES# pin LOW (logic low), wait for at least 3us ( $t_2$ ). Then input commands with below sequence:
  - a. 8Dh 14h for enabling charge pump at 9.0V mode
  - b. AFh for display ON
5. SEG/COM will be ON after 100ms ( $t_{AF}$ ).

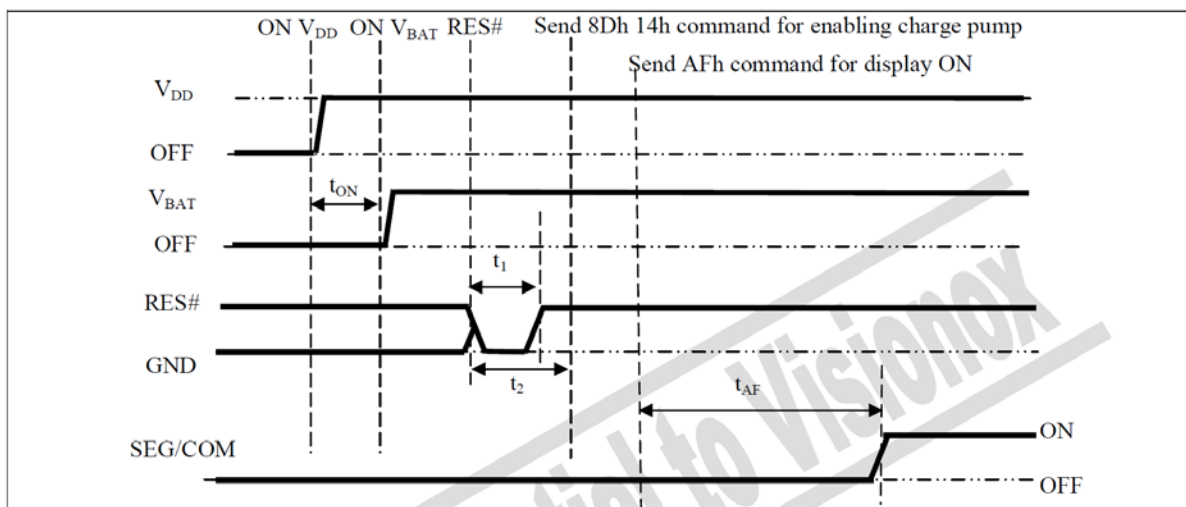

#### Power OFF sequence:

1. Send command AEh for display OFF
2. Send command 8Dh 10h to disable charge pump
3. Power OFF VBAT after  $t_{OFF}$ .<sup>(1),(2)</sup> (Typical  $t_{OFF} = 100ms$ )
4. Power OFF VDD after  $t_{OFF2}$ . (where Minimum  $t_{OFF2} = 0ms$ <sup>(4)</sup>, Typical  $t_{OFF2} = 5ms$ )

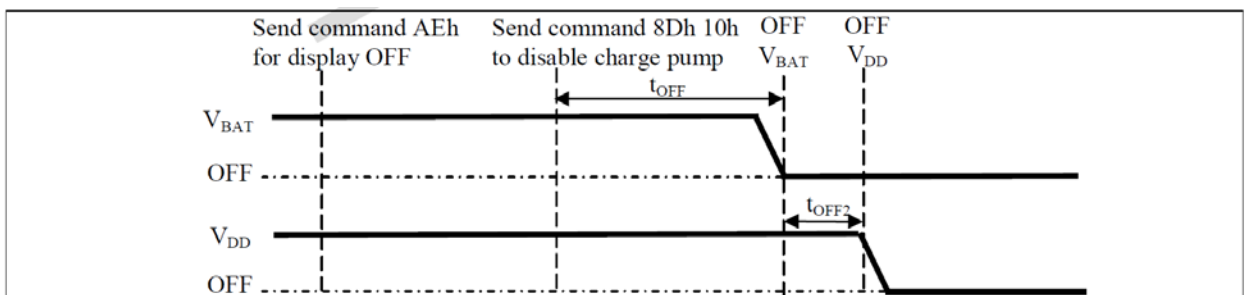

#### Note:

- (1) VBAT should be kept float (i.e. disable) when it is OFF.
- (2) Power Pins (VDD, VBAT) can never be pulled to ground under any circumstance.
- (3) The register values are reset after  $t_1$ .
- (4) VDD should not be Power OFF before VBAT Power OFF

### 9.3 Application Circuit

#### 1) Application Example of M01633 with Internal Charge Pump and I<sup>2</sup>C mode.

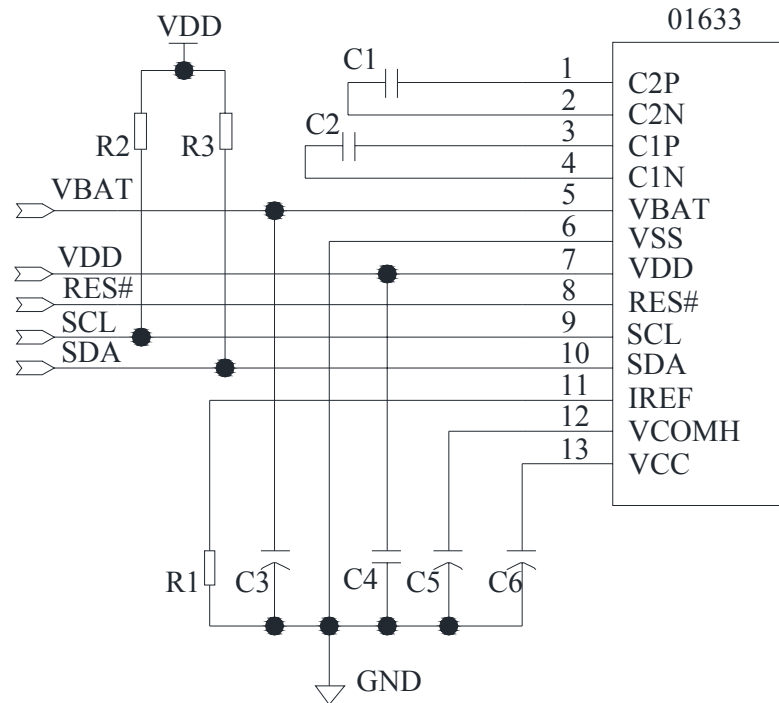

Pin connected to MCU interface: SCL, SDA, RES#

Under Internal DC/DC Mode, the Charge Pump Setting(8Dh) must be set as follow:

8Dh: Charge Pump Setting

14h; Enable Charge Pump at 9.0V mode

The I<sup>2</sup>C address is 0x78.

#### Recommended components

C3,C5,C6: 4.7μF/16V.RoHS (Tantalum Capacitors)

C1,C2,C4: 1uF-0603-X7R±10%.RoHS

R1: 0603 1/10W +/-5% 390Kohm.RoHS

R2,R3: 0603 1/10W +/-5% 10Kohm.RoHS

2) Application Example of M01633 with External VCC and I<sup>2</sup>C mode.

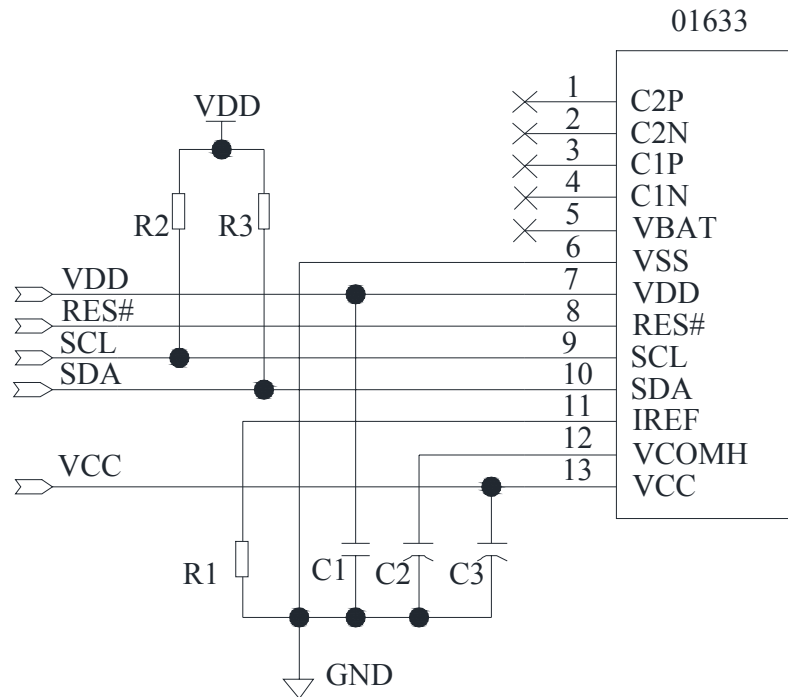

Pin connected to MCU interface: SCL, SDA, RES#

C1P, C1N, C2P, C2N,VBAT should be left open.

Under external VCC Mode, the Charge Pump Setting(8Dh) must be set as follow:

8Dh: Charge Pump Setting

10h; Disable Charge Pump

The I<sup>2</sup>C address is 0x78.

**Recommended components**

C2,C3: 4.7μF/16V.RoHS (Tantalum Capacitors)

C1: 1uF-0603-X7R±10%.RoHS

R1: 0603 1/10W +/-5% 390Kohm.RoHS

R2,R3: 0603 1/10W +/-5% 10Kohm.RoHS

### 9.4 External DC-DC application circuit

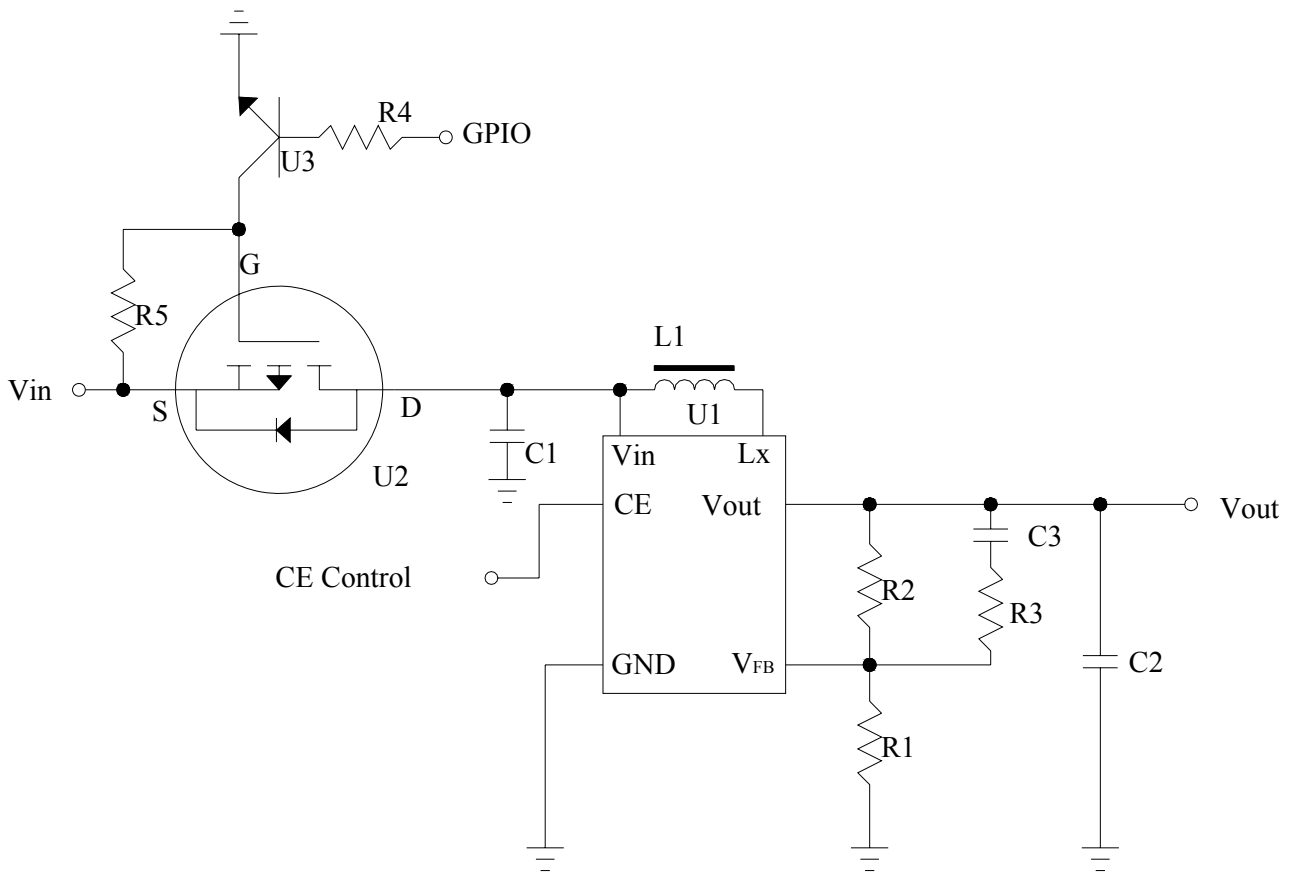

#### Recommend component

The C1	: 1 uF-0603-X7R±10%.RoHS
The C2	: 1 uF-0603-X7R±10%.RoHS
The C3	: 220pF-0603-X7R±10%.RoHS
The R1	: 0603 1/10W +/-5% 10Kohm.RoHS
The R2	: 0603 1/10W +/-1% 80Kohm.RoHS
The R3	: 0603 1/10W +/-5% 2Kohm.RoHS
The R4	: 0603 1/10W +/-5% 1Kohm.RoHS
The R5	: 0603 1/10W +/-5% 10Kohm.RoHS
The L1	: 22uH
The U1	: R1200
The U2	: FDN338P
The U3	: 8050

## 9.5 Display Control Instruction

Refer to SSD1316 IC Specification.





## 9.6 Recommended Software Initialization

In order to ensure the reliability and stability of the module, the module must initialize use the following code, Malfunctioning of the module may occur and the reliability of the module may deteriorate if the module is used beyond the initialize code.

```
void Init_IC()
{
    Write_Command(0xAE);    //Set Display Off
    Write_Command(0xD5);    //Display divide ratio/osc. freq. mode
    Write_Command(0xC1);
    Write_Command(0xA8);    //Multiplex ration mode:
    Write_Command(0x1F);
    Write_Command(0xAD);    //External or Internal VCOMH IREF Selection
    Write_Command(0x00);    // Internal VCOMH/ External IREF
    Write_Command(0x20);    //Set Memory Addressing Mode
    Write_Command(0x02);    //Page Addressing Mode
    Write_Command(0xD3);    //Set Display Offset
    Write_Command(0x00);
    Write_Command(0x40);    //Set Display Start Line
    Write_Command(0x8D);    //DC-DC Control Mode Set
    Write_Command(0x14);    //DC-DC ON/OFF Mode Set
    Write_Command(0xA0);    //Segment Remap
    Write_Command(0xC8);    //Set COM Output Scan Direction
    Write_Command(0xDA);    // Set seg pads hardware
    Write_Command(0x12);
    Write_Command(0x81);    //Contrast control
    Write_Command(0x75);
    Write_Command(0xD9);    //Set pre-charge period
    Write_Command(0x22);
    Write_Command(0xDB);    //VCOM deselect level mode
    Write_Command(0x00);
    Write_Command(0xA4);    //Set Entire Display On/Off
    Write_Command(0xA6);    //Set Normal Display
    Clear_Screen();
    Write_Command(0xAF);    //Set Display On
}
```

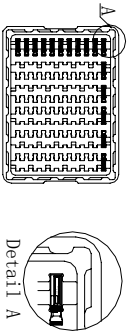
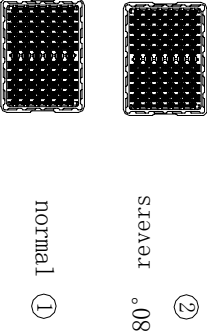

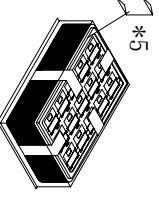
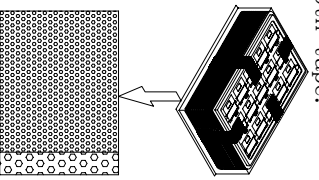
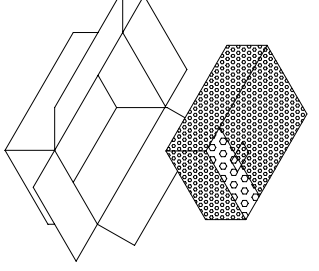
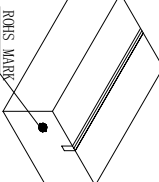
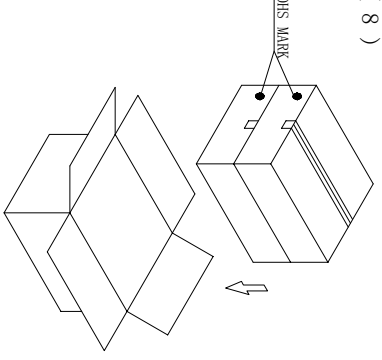
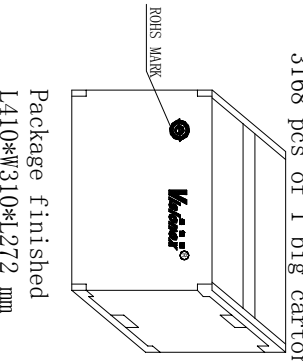
### 10 Package Specification

Controlled Seal		Packing Process (1) ~ (9)			
<p>( 1 ) TRAY Type:01632-MT6-A</p> 	<p>( 2 )</p>  <p>TRAY</p>	<p>( 3 ) order ①、② ①、② fix trays with tape 1584 pcs of 1 small carton 1 tray contain 72 pcs 22 contained trays, 1 empty tray</p> 	<p>( 4 ) package with plastic bags add five desiccants create a power vacuum *5</p> 		
<p>( 5 ) After tray be packaged, wrap the package in a bubble bag and seal with seoth tape.</p> 	<p>( 6 )</p> 	<p>( 7 )</p> <p>small carton package</p> 	<p>( 8 )</p> <p>2 small cartons in 1 big carton</p> 		
<p>( 9 ) 24 contained trays, 2 empty trays, Package quantity products: 3168 pcs of 1 big carton</p>  <p>Package finished L410*W310*L272 mm</p>	<p>NOTE:1、 The inner carton and master carton must be sealed with adhesive tape. 2、 Fill up the gap with EPE. 3、 If the customer has special needs with the RoHS making, the inner carton and master carton need adhesive new RoHS marking at .</p>				

## 11 Reliability

### 11.1 Reliability Test

NO.	ITEM	CONDITION	QUANTITY
1	High Temperature (Non-operation)	85°C,240hrs	4
2	Low Temperature (Non-operation)	-40°C,240hrs	4
3	High Temperature (Operation)	70°C,240hrs	4
4	Low Temperature (Operation)	-40°C,240hrs	4
5	High Temperature / High Humidity (Operation)	60°C,90%RH,240hrs	4
6	Thermal shock (Non-operation)	-40°C~85°C (-40°C/30min;transit/3min;85°C/30min;transit/3min) 1cycle: 66min,30cycles	4
7	Vibration	Frequency: 5~50Hz,0.5G Scan rate: 1 oct/min Time: 2 hrs/axis Test axis: X, Y, Z	1 Carton
8	Drop	Height: 100 cm Sequence: 1 angle, 3 edges and 6 faces	1 Carton

#### Test and measurement conditions

- All measurements shall not be started until the specimens attain to temperature stability, the stable time is at least 15 minutes.
- The degradation of polarizer is ignored for item 5.
- The tolerance of temperature is  $\pm 3^{\circ}\text{C}$ , and the tolerance of relative humidity is  $\pm 5\%$ .

#### Evaluation criteria

- The function test is OK.
- No observable defects.
- Luminance:  $\geq 50\%$  of initial value.
- Current consumption: within  $\pm 50\%$  of initial value.

### 11.2 Lifetime

End of lifetime is specified as 50% of initial brightness and the test pattern at operating condition is 50% alternating checkerboard.

ITEM	MIN	MAX	UNIT	CONDITION
Operation Life Time	7,000	-	hrs	480 cd/m <sup>2</sup> , 50% alternating checkerboard, 22 $\pm$ 3°C, 55 $\pm$ 15% RH

### 11.3 Failure Check Standard

After the completion of the described reliability test, the samples were left at room temperature for 2 hrs prior to conducting the failure test at 22 $\pm$ 3°C; 55 $\pm$ 15% RH.

**11 Illustration of OLED Product Name**

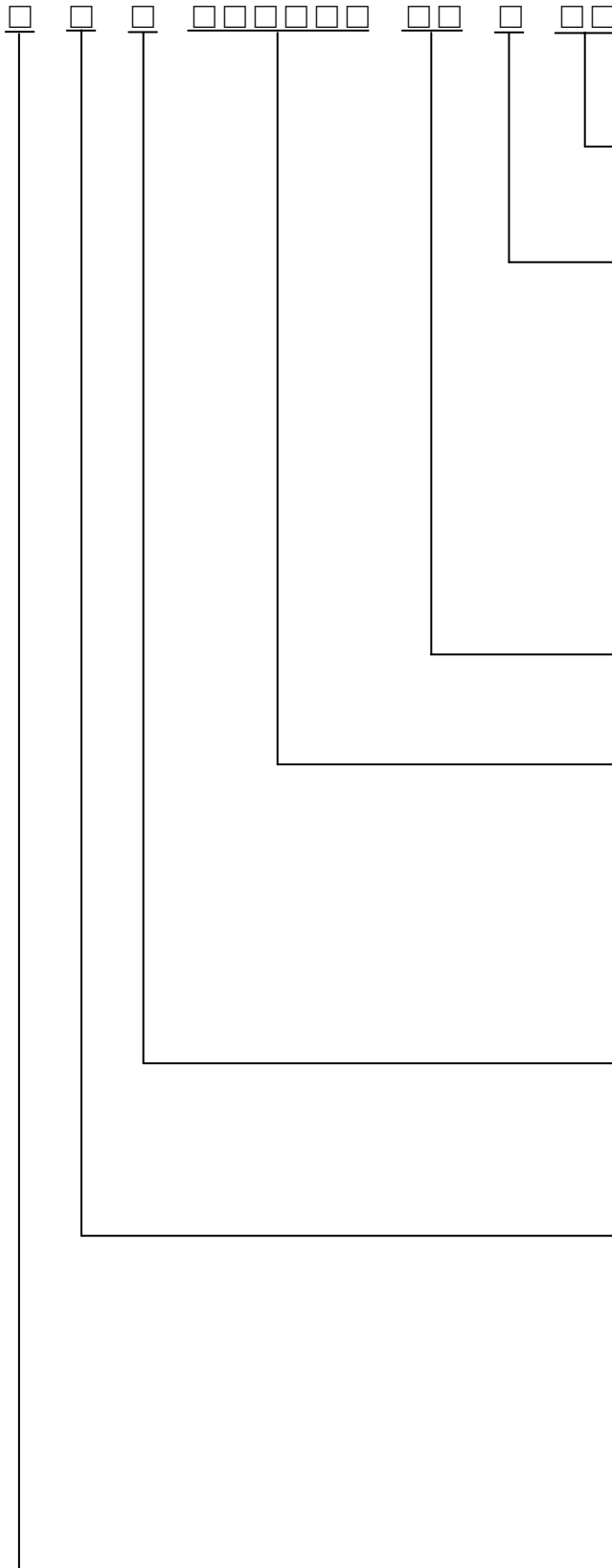

**Flow No. :**

01~99

**Display Color :**

R—red

G—green

B—blue

Y—yellow

M—amber

W—white

A—area color

F—full color

**Panel Flow No. :**

A0~A9, B0~B9...Z0~Z9

**Display Format :**

Graphic—columns and rows

Character—characters and line number

Segment—segment number

Icon—pixel number

**Product Type :**

P—panel

M—module

**Display Type :**

G—graphic

C—character

S—segment

I—Icon

M—mixed

**Company :**

V—Visionox

## 12 Outgoing Quality Control Specifications

### 12.1 Sampling Method

- (1) GB/T 2828.1-2003/ISO2859-1: 1999, inspection level II , normal inspection, single sample inspection
- (2) AQL: Major 0.65; Minor 1.0

### 12.2 Inspection Conditions

The environmental conditions for test and measurement are performed as follows.

Temperature:  $22\pm 3^{\circ}\text{C}$

Humidity:  $55\pm 15\%\text{R.H}$

Fluorescent Lamp: 30W

Distance between the Panel & Lamp:  $\geq 50\text{cm}$

Distance between the Panel & Eyes:  $\geq 30\text{cm}$

Viewing angle from the vertical in each direction:  $\leq 45^{\circ}$

(See the sketch below)

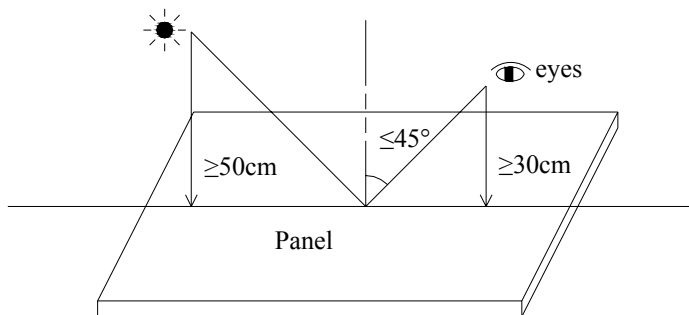

### 12.3 Quality Assurance Zones

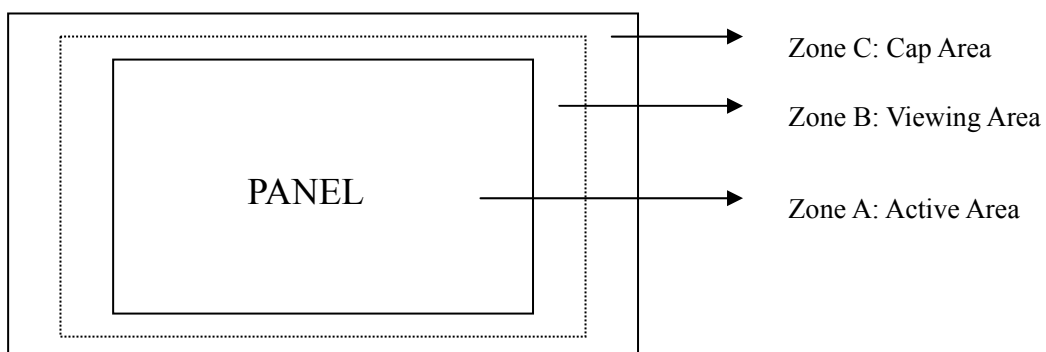

### 12.4 Inspection Standard

Definition of  $\Phi$ &L&W (Unit: mm)

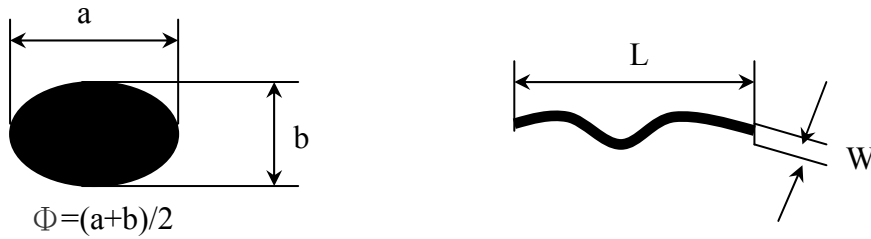

#### I . Appearance Defects

NO.	ITEM	CRITERIA	CLASSIFICATION																		
1	Polarizer Black or White spot, Dirty spot, Foreign matter, Dent on the polarizer	<table border="1"> <thead> <tr> <th rowspan="2">Average Diameter (mm)</th> <th colspan="2">Acceptable Number</th> </tr> <tr> <th>Zone A,B</th> <th>Zone C</th> </tr> </thead> <tbody> <tr> <td><math>\Phi \leq 0.15</math></td> <td colspan="2">Ignore</td> </tr> <tr> <td><math>0.15 &lt; \Phi \leq 0.30</math></td> <td colspan="2">3</td> </tr> <tr> <td><math>\Phi &gt; 0.30</math></td> <td colspan="2">0</td> </tr> </tbody> </table>	Average Diameter (mm)	Acceptable Number		Zone A,B	Zone C	$\Phi \leq 0.15$	Ignore		$0.15 < \Phi \leq 0.30$	3		$\Phi > 0.30$	0		Minor				
Average Diameter (mm)	Acceptable Number																				
	Zone A,B	Zone C																			
$\Phi \leq 0.15$	Ignore																				
$0.15 < \Phi \leq 0.30$	3																				
$\Phi > 0.30$	0																				
2	Scratch/line on the glass/Polarizer	<table border="1"> <thead> <tr> <th rowspan="2">Width (mm)</th> <th rowspan="2">Length (mm)</th> <th colspan="2">Acceptable Number</th> </tr> <tr> <th>Zone A,B</th> <th>Zone C</th> </tr> </thead> <tbody> <tr> <td><math>W \leq 0.03</math></td> <td>---</td> <td colspan="2">Ignore</td> </tr> <tr> <td><math>0.03 &lt; W \leq 0.08</math></td> <td><math>L \leq 5.0</math></td> <td colspan="2">3</td> </tr> <tr> <td><math>W &gt; 0.08</math></td> <td>---</td> <td colspan="2">0</td> </tr> </tbody> </table>	Width (mm)	Length (mm)	Acceptable Number		Zone A,B	Zone C	$W \leq 0.03$	---	Ignore		$0.03 < W \leq 0.08$	$L \leq 5.0$	3		$W > 0.08$	---	0		Minor
Width (mm)	Length (mm)	Acceptable Number																			
		Zone A,B	Zone C																		
$W \leq 0.03$	---	Ignore																			
$0.03 < W \leq 0.08$	$L \leq 5.0$	3																			
$W > 0.08$	---	0																			
3	Polarizer Bubble	<table border="1"> <thead> <tr> <th rowspan="2">Average Diameter (mm)</th> <th colspan="2">Acceptable Number</th> </tr> <tr> <th>Zone A,B</th> <th>Zone C</th> </tr> </thead> <tbody> <tr> <td><math>\Phi &gt; 0.5</math></td> <td colspan="2">0</td> </tr> <tr> <td><math>0.2 &lt; \Phi \leq 0.5</math></td> <td colspan="2">3</td> </tr> <tr> <td><math>\Phi \leq 0.2</math></td> <td colspan="2">Ignore</td> </tr> </tbody> </table>	Average Diameter (mm)	Acceptable Number		Zone A,B	Zone C	$\Phi > 0.5$	0		$0.2 < \Phi \leq 0.5$	3		$\Phi \leq 0.2$	Ignore		Minor				
Average Diameter (mm)	Acceptable Number																				
	Zone A,B	Zone C																			
$\Phi > 0.5$	0																				
$0.2 < \Phi \leq 0.5$	3																				
$\Phi \leq 0.2$	Ignore																				
4	Any Dirt & Scratch on Polarizer's Protective Film	Ignore for not affect the polarizer.	Minor																		
5	Any Dirt on Cap Glass	<table border="1"> <thead> <tr> <th>Average Diameter (mm)</th> <th>Acceptable Number</th> </tr> </thead> <tbody> <tr> <td><math>\Phi \leq 0.5</math></td> <td>Ignore</td> </tr> <tr> <td><math>0.5 &lt; \Phi \leq 1.0</math></td> <td>3</td> </tr> <tr> <td><math>\Phi &gt; 1.0</math></td> <td>0</td> </tr> </tbody> </table>	Average Diameter (mm)	Acceptable Number	$\Phi \leq 0.5$	Ignore	$0.5 < \Phi \leq 1.0$	3	$\Phi > 1.0$	0	Minor										
Average Diameter (mm)	Acceptable Number																				
$\Phi \leq 0.5$	Ignore																				
$0.5 < \Phi \leq 1.0$	3																				
$\Phi > 1.0$	0																				

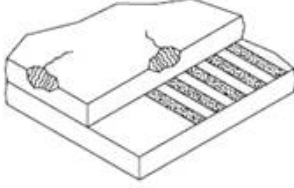
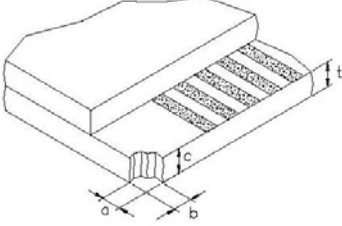
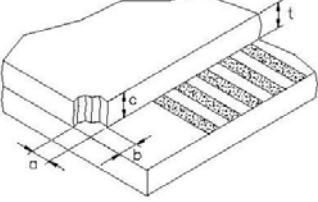
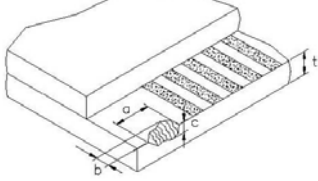
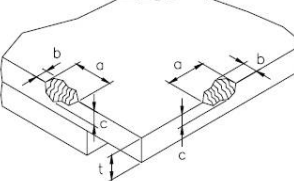
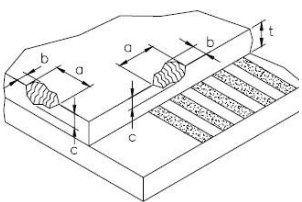
6	Glass Crack	 <p>Propagation crack is not acceptable.</p>	Major
7	Corner Chip	 <p>t= Glass thickness Accept <math>a \leq 2.0\text{mm}</math> or <math>b \leq 2.0\text{mm}</math>, <math>c \leq t</math></p>	Minor
8	Corner Chip on Cap Glass	 <p>t= Glass thickness Accept <math>a \leq 1.5\text{mm}</math> or <math>b \leq 1.5\text{mm}</math>, <math>c \leq t</math></p>	Minor
9	Chip on Contact Pad	 <p>t= Glass thickness Accept <math>a \leq 3.0\text{mm}</math> or <math>b \leq 0.8\text{mm}</math>, <math>c \leq t</math> (on the contact pin) <math>a \leq 3.0\text{mm}</math> or <math>b \leq 1.5\text{mm}</math>, <math>c \leq t</math> (outside of the contact pin)</p>	Minor
10	Chip on Face of Display	 <p>t= Glass thickness Accept <math>a \leq 1.5\text{mm}</math> or <math>b \leq 1.5\text{mm}</math>, <math>c \leq t</math></p>	Minor
11	Chip on Cap Glass	 <p>t= Glass thickness Accept <math>a \leq 3.0\text{mm}</math> or <math>b \leq 3.0\text{mm}</math>, <math>c \leq t/2</math> <math>a \leq 1.5\text{mm}</math> or <math>b \leq 1.5\text{mm}</math>, <math>t/2 \leq c \leq t</math></p>	Minor
12	Stain on Surface	Stain removable by soft cloth or air blow is acceptable.	Minor
13	TCP/FPC Damage	<p>(1) Crack, deep scratch, deep hole and deep pressure mark on the TCP/FPC are not acceptable.</p> <p>(2) Terminal lead twisted or broken is not allowable.</p> <p>(3) Copper exposed is not allowed by naked eye inspection.</p>	Minor
14	Dimension Unconformity	Checking by mechanical drawing.	Major

**II. Displaying Defects**

NO.	ITEM	CRITERIA	CLASSIFICATION															
1	Black/White spot Dirty spot Foreign matter	<table border="1"> <thead> <tr> <th data-bbox="517 371 794 439">Average Diameter (mm)</th> <th colspan="2" data-bbox="794 371 1155 405">Pieces Permitted</th> </tr> <tr> <td data-bbox="517 439 794 472"><math>\Phi \leq 0.10</math></td> <td data-bbox="794 405 979 439">Zone A,B</td> <td data-bbox="979 405 1155 439">Zone C</td> </tr> <tr> <td data-bbox="517 472 794 506"><math>0.10 &lt; \Phi \leq 0.20</math></td> <td colspan="2" data-bbox="794 439 1155 472">Ignore</td> </tr> <tr> <td data-bbox="517 506 794 539"><math>\Phi &gt; 0.20</math></td> <td data-bbox="794 472 979 506">3</td> <td data-bbox="979 472 1155 506">Ignore</td> </tr> <tr> <td data-bbox="517 539 794 568"><math>\Phi &gt; 0.20</math></td> <td data-bbox="794 506 979 539">0</td> <td data-bbox="979 506 1155 539">Ignore</td> </tr> </thead> </table>	Average Diameter (mm)	Pieces Permitted		$\Phi \leq 0.10$	Zone A,B	Zone C	$0.10 < \Phi \leq 0.20$	Ignore		$\Phi > 0.20$	3	Ignore	$\Phi > 0.20$	0	Ignore	Minor
Average Diameter (mm)	Pieces Permitted																	
$\Phi \leq 0.10$	Zone A,B	Zone C																
$0.10 < \Phi \leq 0.20$	Ignore																	
$\Phi > 0.20$	3	Ignore																
$\Phi > 0.20$	0	Ignore																
2	No Display	Not allowable.	Major															
3	Irregular Display	Not allowable.	Major															
4	Missing Line (row or column)	Not allowable.	Major															
5	Short	Not allowable.	Major															
6	Flicker	Not allowable.	Major															
7	Abnormal Color	Refer to the SPEC.	Major															
8	Luminance NG	Refer to the SPEC.	Major															
9	Over Current	Refer to the SPEC.	Major															

## 13 Precautions for operation and Storage

### 13.1 Precautions for Operation

- (1) Since OLED panel is made of glass, do not apply any mechanical shock or impact or excessive force to it when installing the OLED module. Any strong mechanical impact due to falling dropping etc. may cause damage (breakage or cracking).
- (2) The polarizer on the OLED surface is made of soft material and is easily scratched. Please take most care when handing. When the surface of the polarizer of OLED Module is contaminated, please wipe it off gently by using moisten soft cloth with isopropyl alcohol, do not use water, ketone or aromatics. If there is saliva or water on the OLED surface, please wipe it off immediately.
- (3) When handling OLED module, please be sure that the body and the tools are properly grounded. And do not touch I/O pins with bare hands or contaminate I/O pins, it will cause disconnection or defective insulation of terminals.
- (4) Do not attempt to disassemble or process the OLED module.
- (5) OLED module should be used under recommended operating conditions shown in the specification. Since the higher voltage leads to the shorter lifetime, be sure to use the specified operating voltage.
- (6) Foggy dew, moisture condensation or water droplets deposited on surface and contact terminals will cause polarizer stain or damage, the deteriorated display quality and electrochemical reaction then leads to shorter life time and permanent damage to the module probably. Please pay attention to the environmental temperature and humidity.
- (7) An afterimage is created by the difference in brightness between unused dot and the fixed dot, according to the decrease of brightness of the emitting time. Therefore, to avoid having an afterimage, the full set should be thoroughly used instead of using a fixed dot. When the fixed dot emits, an afterimage can be created.
- (8) Flicker could be come out at full on display. And it disappears when frame frequency increase, but brightness decreases too.

### 13.2 Soldering

- (1) Soldering should be performed only on the I/O terminals.
- (2) Use soldering irons with proper grounding and no leakage.
- (3) Iron: The temperature setting of electric iron is 350°C, but we suggest that during soldering, the temperature of iron tip should be no higher than 330°C and soldering be finished within 3~4 seconds.

### 13.3 Precautions for Storage

- (1) Please store OLED module in a dark place. Avoid exposure to sunlight, the light of fluorescent lamp or any ultraviolet ray.
- (2) Keep the environment temperature between 10°C and 35°C and the relative humidity less than 60%. Avoid high temperature and high humidity.
- (3) Keep the OLED modules stored in the container when shipped from supplier before using them is recommended.
- (4) Do not leave any article on the OLED module surface for an extended period of time.

### 13.4 Warranty period

Visionox warrants for a period of 12 months from the shipping date when stored or used under normal condition.