

DWG. NO.	031-1676		
REVISIONS			
SYM.	E.C.N.	DATE	APVD.
A	24194	3/14/00	
DELETED BLIND HOLES			
B	25121	5/12/03	
DELETED OLD LOGO			

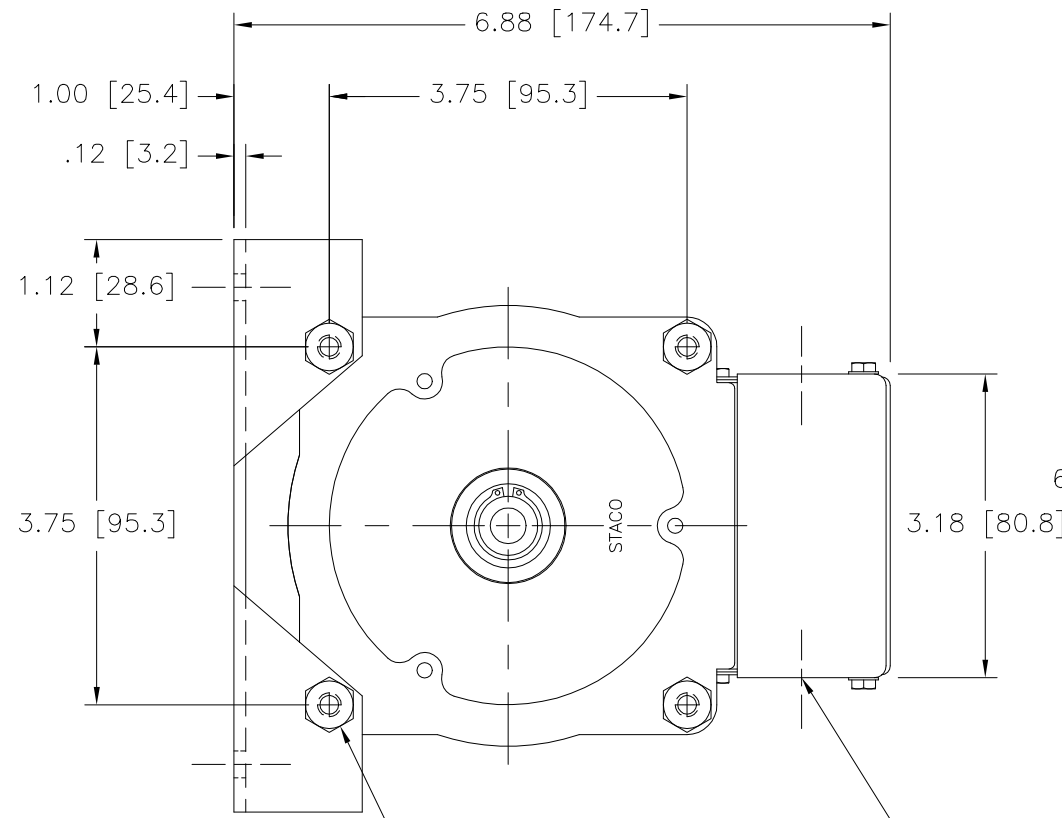

(4) STANDOFFS TAPPED
1/4-28 X .38 [9.5] DEEP
FOR MOUNTING BOLTS

.88 [22.2] DIA. KNOCKOUT
(7) PLACES FOR
WIRING CONNECTIONS

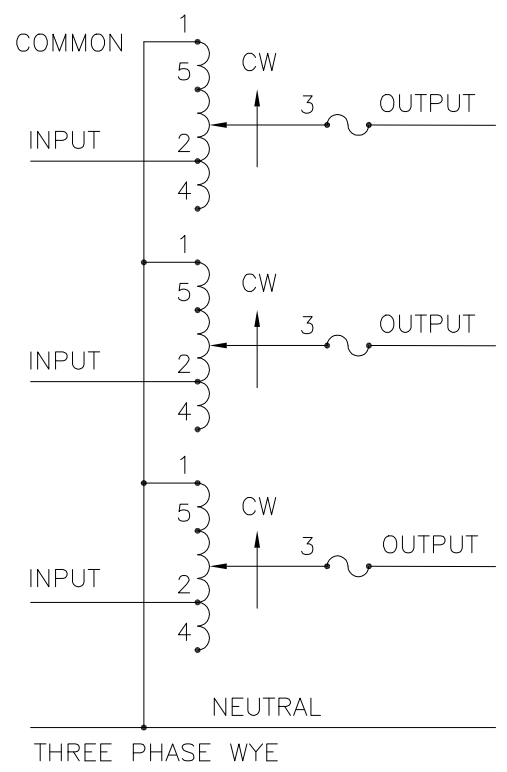
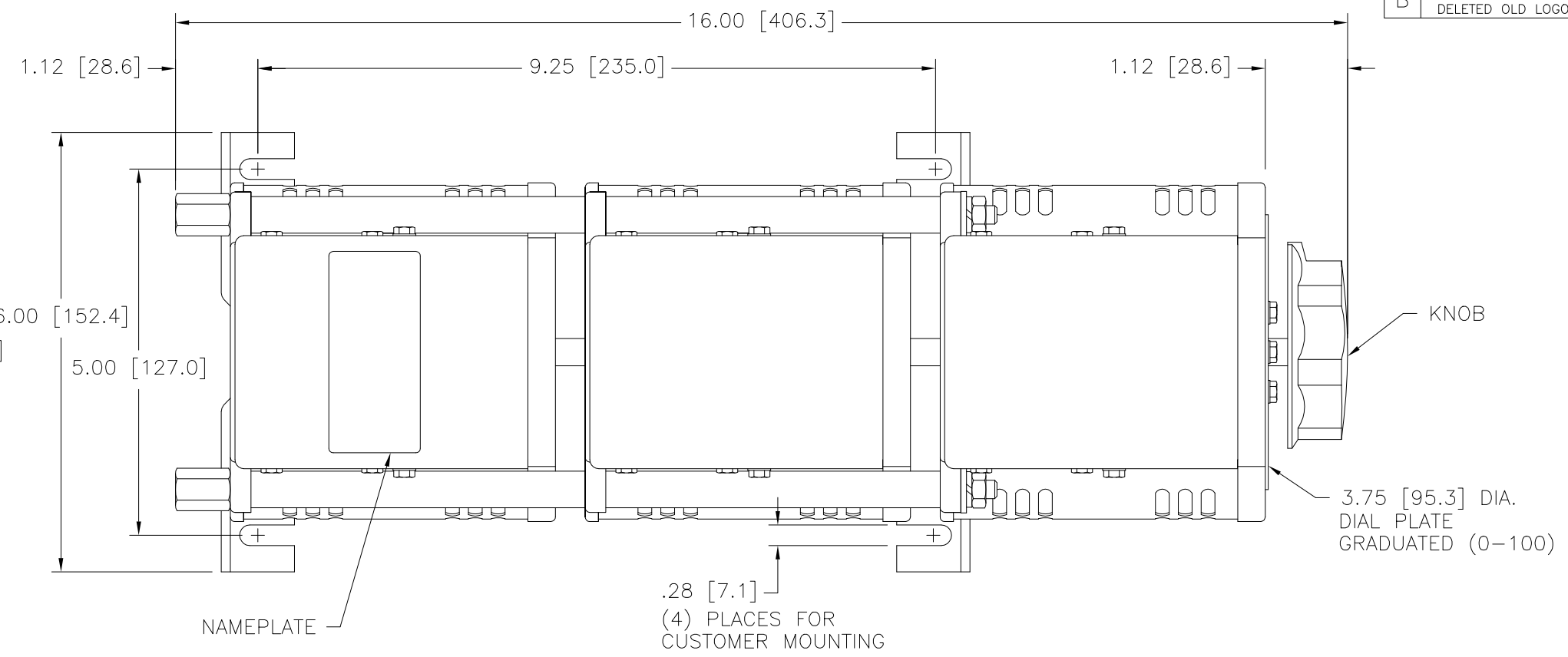

SCHEMATIC
FUSE RECOMMENDED BUT NOT SUPPLIED

⌘ IF GANGED UNITS ARE USED IN A SYSTEM THAT ORDINARILY HAS A COMMON NEUTRAL OR GROUND BETWEEN SOURCE AND LOAD, THE NEUTRAL OR GROUND MUST BE CONNECTED TO THE COMMON TERMINALS OF THE VARIABLE TRANSFORMER ASSEMBLY. IF THE SYSTEM HAS NO NEUTRAL, THE LOAD MUST BE BALANCED OR THE TRANSFORMER WILL BE DAMAGED.

■ JUMPER PROVIDED IN STANDARD COMMON POSITION AND SHOULD BE MOVED OR REMOVED AS REQUIRED.

++ LINE TO LINE VOLTAGE.

SPECIFICATIONS											
WIRING	INPUT		OUTPUT				SHAFT ROTATION TO INCREASE VOLTAGE	TERMINAL CONNECTIONS			
	VOLTS	HERTZ	VOLTS	CONSTANT CURRENT LOAD		CONSTANT IMPEDANCE LOAD		FOR INCREASING VOLTAGE AS VIEWED FROM BASE END ■			
				MAX. AMPS	MAX. KVA	MAX. AMPS		MAX. KVA	INPUT	JUMPER	OUTPUT
THREE PHASE WYE ⌘	240	50/60	0-240	10	4.16	13	5.4	CW	1-1-1	4-4-4	3-3-3
				CCW	4-4-4	1-1-1	3-3-3				
	++	60	0-280	10	4.85	—	—	CW	5-5-5	4-4-4	3-3-3
				CCW	2-2-2	1-1-1	3-3-3				

UNLESS OTHERWISE SPECIFIED, TOLERANCE IS ±
DECIMALS .XX .0000 .06 .005
HOLES .002
ANGLES 1°
DRAFT 1-1/2°
UNITS IN [mm]

MATERIAL: ALL DIMENSIONS APPLY AFTER PLATING

TITLE: SPEC. CONTROL DRAWING
VARIABLE TRANSFORMER
MODEL: 1010BCT-3

STACO ENERGY PRODUCTS CO.
A Components Corporation of Ametec Company
302 South Boulevard Dayton, Ohio 45403 USA

DRAWN BY S.A. SMITH DATE 9/18/97 FIRST USED ON DO NOT SCALE DWG.
CHECKER DATE WEIGHT APPROX. 34.5 LBS CAGE CODE 83008
ENGINEER DATE SCALE 1=1 SHEET 1 OF 1

DWG. NO. 031-1676