

LOC		DIST		REVISIONS			
P	LTN	DESCRIPTION	DATE	DMN	APVD		
V		REV PER ECO 13-009837	6-13-13	CT	DM		

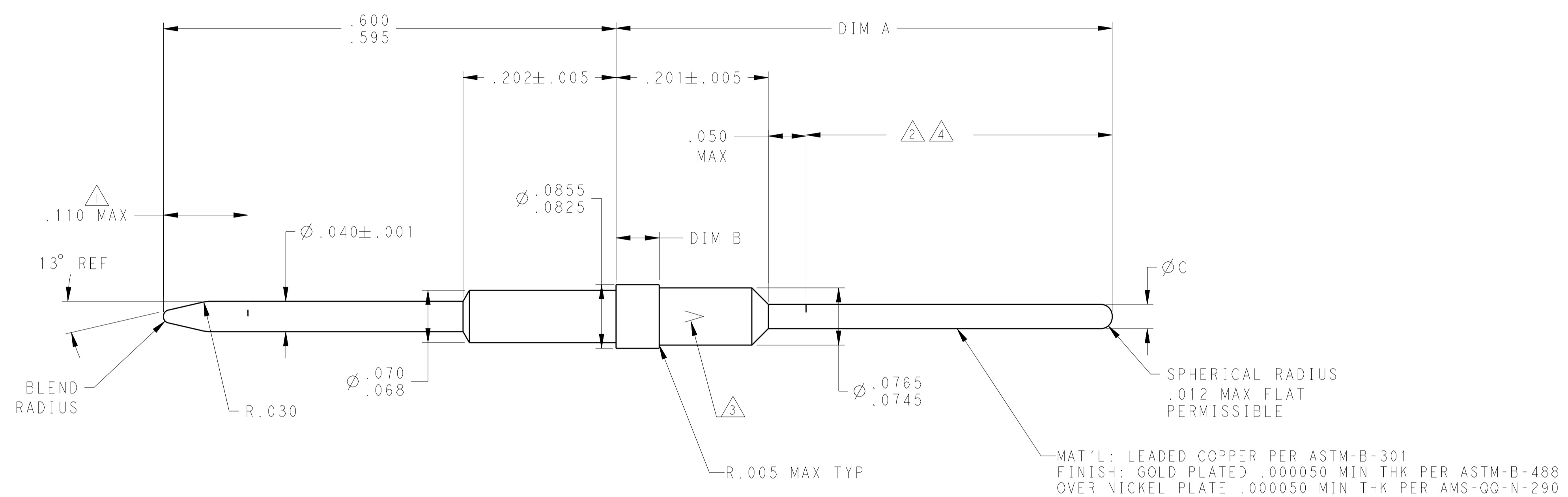

- △ ELECTRICAL ENGAGEMENT POINT.
- ② THIS AREA SOLDER DIPPED.
- ③ MANUFACTURERS LOGO; LACATION & ORIENTATION OPTIONAL.
- ④ SOLDER IS ROHS-COMPLIANT Sn.

△	.038 MAX	.055-.059	.697	4-448138-2
	.030-.034	.055-.059	.697±.005	4-448138-1
② ④	.038 MAX	.055-.059	.780	3-448138-8
②	.038 MAX	.055-.059	.780	3-448138-7
--	.030-.034	.055-.059	.780±.005	3-448138-6
②	.038 MAX	.055-.059	.620±.005	3-448138-3
② ④	.038 MAX	.055-.059	.620±.005	3-448138-2
②	.038 MAX	.055-.059	.905±.005	3-448138-1
--	.030-.034	.055-.059	.905±.005	3-448138-0
②	.038 MAX	.055-.059	.661	2-448138-7
--	.030-.034	.055-.059	.655±.005	2-448138-6
--	.030-.034	.055-.059	.620±.005	2-448138-3
--	.030-.034	.055-.059	.404±.005	2-448138-0
②	.038 MAX	.055-.059	.510±.005	1-448138-7
②	.038 MAX	.055-.059	.546±.005	1-448138-6
--	.030-.034	.055-.059	.546±.005	1-448138-5
--	.030-.034	.055-.059	.510±.005	1-448138-2
--	.030-.034	.0655-.0695	.546	448138-9
--	.030-.034	.0655-.0695	.661	448138-6
--	.030-.034	.0655-.0695	.546	448138-3
REMARKS	DIM C	DIM B	DIM A	PART NO.

THIS DRAWING IS A CONTROLLED DOCUMENT. DWN: C.C. THOMAS 27OCT2009
 CHK: K. THACKSTON 27OCT2009
 APVD: K. THACKSTON 27OCT2009

STE TE Connectivity
 POSTED PIN CONTACT, SIZE 20, ARINC 600

DIMENSIONS: INCHES. TOLERANCES UNLESS OTHERWISE SPECIFIED:
 0 PLC ±.010
 1 PLC ±.
 2 PLC ±.
 3 PLC ±.
 4 PLC ±.
 ANGLES ±.
 FINISH SEE CALLOUTS

MATERIAL: SEE TABLE. WEIGHT: -. SIZE: A100779. CAGE CODE: 448138. DRAWING NO: 448138. SHEET 1 OF 1. REV V.

CUSTOMER DRAWING. SCALE: 15:1. SHEET 1 OF 1. REV V.