

FEATURES

Low Cost

Complete Signal-Conditioning Solution

Small Package: 28-Pin Double DIP

Internal Half-Bridge Completion Resistors

Remote Sensing

High Accuracy

Low Drift: $\pm 0.25\mu\text{V}/^\circ\text{C}$

Low Noise: $0.3\mu\text{V}$ p-p

Low Nonlinearity: $\pm 0.005\%$ max

High CMR: 140dB min (60Hz, $G = 1000\text{V}/\text{V}$)

Programmable Bridge Excitation: +4V to +15V

Adjustable Low Pass Filter: $f_c = 10\text{Hz}$ to 20kHz

APPLICATIONS

Measurement of: Strain, Torque, Force, Pressure

Instrumentation: Indicators, Recorders, Controllers

Data Acquisition Systems

Microcomputer Analog I/O

GENERAL DESCRIPTION

Model 1B31 is a high performance strain gage signal-conditioning component that offers the industry's best price/performance solution for applications involving high-accuracy interface to strain gage transducers and load cells. Packaged in a 28-pin double DIP using hybrid technology, the 1B31 is a compact and highly reliable product. Functionally, the signal conditioner consists of three sections: a precision instrumentation amplifier, a two-pole low pass filter, and an adjustable transducer excitation.

The instrumentation amplifier (IA) section features low input offset drift of $\pm 0.25\mu\text{V}/^\circ\text{C}$ (RTI, $G = 1000\text{V}/\text{V}$) and excellent nonlinearity of $\pm 0.005\%$ max. In addition, the IA exhibits low noise of $0.3\mu\text{V}$ p-p typ (0.1Hz-10Hz), and outstanding 140dB min common-mode rejection ($G = 1000\text{V}/\text{V}$, 60Hz). The gain is programmable from 2V/V up to 5000V/V by one external resistor.

The two-pole low pass filter offers a 40dB/decade roll-off from 1kHz to reduce high frequency noise and improve system signal-to-noise ratio. The corner frequency is adjustable downwards by external capacitors and upwards to 20kHz by three resistors. The output voltage can also be offset by $\pm 10\text{V}$ with an external potentiometer to null out dead weight.

The 1B31's regulated transducer excitation stage features low output drift ($\pm 0.004\%/^\circ\text{C}$ typ) and can drive 120 Ω or higher resistance load cells. The excitation is preset at +10V and is adjustable from +4V and +15V. This section also has remote sensing capability to allow for lead-wire compensation in 6-wire bridge configurations. For half-bridge strain gages, a matched

FUNCTIONAL BLOCK DIAGRAM

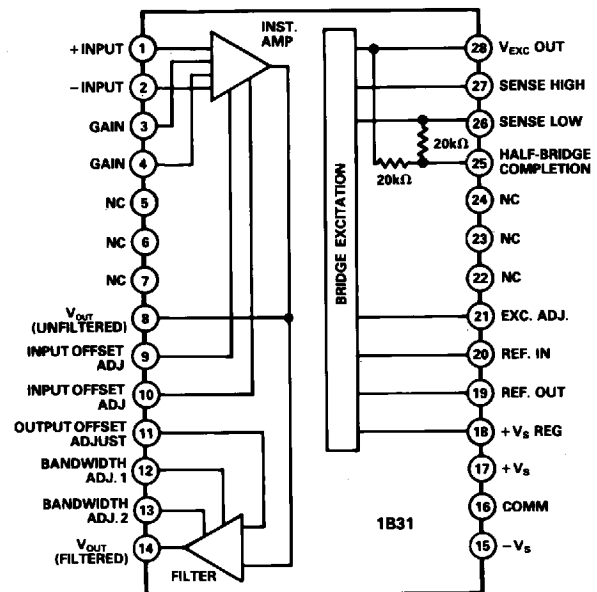

pair of thin-film 20k Ω resistors is connected across the excitation outputs. This assures temperature tracking of $\pm 5\text{ppm}/^\circ\text{C}$ max and reduces part count.

The 1B31 is available in a plastic package specified over the industrial (-40°C to $+85^\circ\text{C}$) temperature range and will be available soon in a bottom-brazed ceramic package specified over the military (-55°C to $+125^\circ\text{C}$) temperature range.

DESIGN FEATURES AND USER BENEFITS

Ease of Use: Direct transducer interface with minimum external parts required, convenient offset and span adjustment capability.

Half-Bridge Completion: Matched resistor pair tracking to $\pm 5\text{ppm}/^\circ\text{C}$ max for half-bridge strain gage applications.

Remote Sensing: Voltage drops across the excitation lead-wires are compensated by the regulated supply, making 6-wire load-cell interfacing straightforward.

Programmable Transducer Excitation: Excitation source preset for +10V dc operation without external components. User-programmable from a +4V to +15V dc to optimize transducer performance.

Adjustable Low Pass Filter: The two-pole active filter ($f_c = 1\text{kHz}$) reduces noise bandwidth and aliasing errors with provisions for external adjustment of cutoff frequency (10Hz to 20kHz).

Model	1B31AN	1B31SD†
BRIDGE EXCITATION		
Regulator Input Voltage Range	+ 9.5V to + 28V	*
Output Voltage Range	+ 4V to + 15V	*
Regulator Input/Output Voltage Differential	+ 3V to + 24V	*
Output Current ⁵	100mA max	*
Regulation, Output Voltage vs. Supply	± 0.05%/V	*
Load Regulation, I _L = 1mA to 50mA	± 0.1%	*
Output Voltage vs. Temperature	± 0.004%/°C	*
Output Noise, 10Hz to 1kHz ⁶	200µV p-p	*
Reference Voltage (Internal)	+ 6.8V ± 5%	*
Internal Half-Bridge Completion		
Nominal Resistor Value	20kΩ ± 1%	*
Temperature Tracking	± 5ppm/°C max	*
POWER SUPPLY		
Voltage, Rated Performance	± 15V dc	*
Voltage, Operating	± 12V to ± 18V dc	*
Current, Quiescent ⁷	+ 10mA	*
ENVIRONMENTAL		
Temperature Range		
Rated Performance	-40°C to +85°C	-55°C to +125°C
Operating	-40°C to +85°C	-55°C to +125°C
Storage	-40°C to +100°C	-65°C to +150°C
Relative Humidity	0 to 95% @ +60°C	*
CASE SIZE		
	0.83" × 1.64" × 0.25" (21.1 × 41.7 × 6.350mm) max	0.81" × 1.57" × 0.23" (20.6 × 40.0 × 5.72mm)

NOTES

- *Specifications same as 1B31AN.
 - †SD grade available in Spring 1988.
 - ¹Specifications referred to the filtered output at Pin 14.
 - ²Exclusive of external gain setting resistor.
 - ³Unadjusted filter setting.
 - ⁴Filter cutoff frequency set with external capacitors.
 - ⁵Derate from +50°C as shown in Figure 14.
 - ⁶4.7µF capacitor from V_{REF IN} (Pin 20) to COMM.
 - ⁷Excluding bridge excitation's current, and with no loading on the output.
- Specifications subject to change without notice.

AC1222 MOUNTING CARD

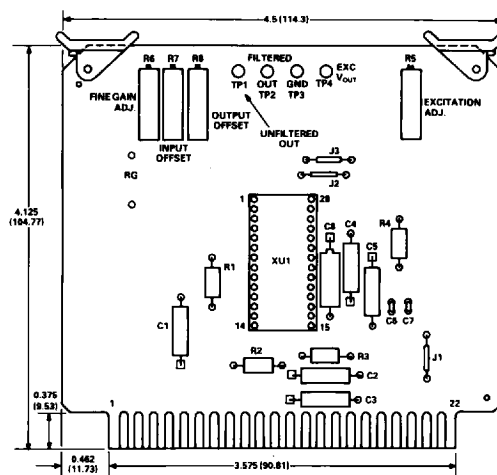

AC1222 CONNECTOR DESIGNATION

PIN	FUNCTION	PIN	FUNCTION
1	+ INPUT	S	V _{exc} OUT
2	- INPUT	T	SENSE HIGH
3	N/C	U	SENSE LOW
4	GAIN (3)	V	HALF-BRIDGE COMP.
5	GAIN (4)	X	REF OUT
6	V _{out} (UNFILTERED)	Y	REF IN
7	INPUT OFFSET ADJ. (9)	Z	EXC. ADJ.
8	INPUT OFFSET ADJ. (10)		
9	OUTPUT OFFSET ADJ.		
10	BANDWIDTH ADJ. 1		
11	BANDWIDTH ADJ. 2		
12	V _{out} (FILTERED)		
13	-V _s		
14	V _{out} (FILTERED)		
15	-V _s		
16	COMMON		
17	+V _s		
18	+V _s REG		
19			
20			
21			
22			

The AC1222 mounting card is available for the 1B31. The AC1222 is an edge connector card with a 28-pin socket for plugging in the 1B31. In addition, it has provisions for installing the gain resistor and adjusting the bridge excitation voltage and cutoff frequency. Adjustment potentiometers for offset, fine gain and excitation are also provided. The AC1222 comes with a Cinch 251-22-30-160 (or equivalent) edge connector.

APPLICATIONS

The 1B31 can be interfaced easily and directly to a wide variety of transducers for precise measurement of strain, torque, force and pressure. For applications in harsh industrial environments, such characteristics as high CMR, low noise and excellent temperature stability make the 1B31 unsurpassed for use in indicators, recorders and controllers.

The combination of low cost, small size and high performance of the 1B31 allows the system designer to use one conditioner per channel. The advantages include significantly lower system noise and high resolution, and elimination of crosstalk and aliasing errors.

FUNCTIONAL DESCRIPTION

Model 1B31 is based on a two-stage amplifier design and an adjustable voltage regulator section, as shown in Figure 1. The front end is a low noise, low drift, instrumentation amplifier (IA) that is optimized to amplify low level transducer signals (from 2mV full scale) riding on high common-mode voltage (± 9.5V). The gain of the IA is programmed by a single resistor (1V/V to 2500V/V) and the input offset nulled out by an external potentiometer across the offset adjust Pins 9 and 10. The inverted signal (V_{-INPUT} - V_{+INPUT}) is brought out to Pin 8 for applications such as vibration and torque testing where the unfiltered output is required.

The signal is also fed to an inverting Butterworth filter with a fixed gain of -2V/V. This two-pole filter is preset with a 1kHz

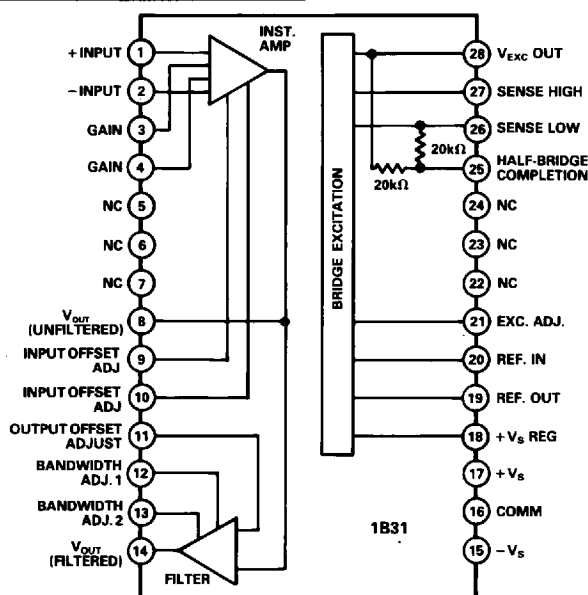

Figure 1. Block Diagram and Pinout

corner frequency which can be adjusted downwards to 10Hz by using two external capacitors or upwards to 20kHz by three resistors. This stage also provides a convenient means of adjusting output offset voltage (± 10V) by connecting a 50kΩ potentiometer to Pin 11.

1B31

The bridge excitation section is an adjustable output, regulated supply with an internally provided reference voltage (+6.8V). It is configured as a gain stage with the output preset at +10V. The excitation voltage is increased by connecting a resistor between Pins 21 and 26, and decreased by connecting a resistor between Pins 19 and 20. Sense lines are provided to compensate for lead-wire resistance by effectively bringing the leads into the feedback loop.

For half-bridge applications, two tracking thin-film resistors (20kΩ, ±5ppm/°C max) are connected from V_{EXC OUT} (Pin 28) to SENSE LOW (Pin 26).

OPERATING INSTRUCTIONS

Gain Setting: The differential gain, G, is determined by the equation:

$$G = 2 + \frac{80k\Omega}{R_G}$$

where R_G is connected between the GAIN terminals (Pins 3 and 4) of the 1B31, as shown in Figure 2. For best performance, a low temperature coefficient (5ppm/°C) R_G is recommended. For fine span adjustment, a 50Ω potentiometer may be connected in series with R_G.

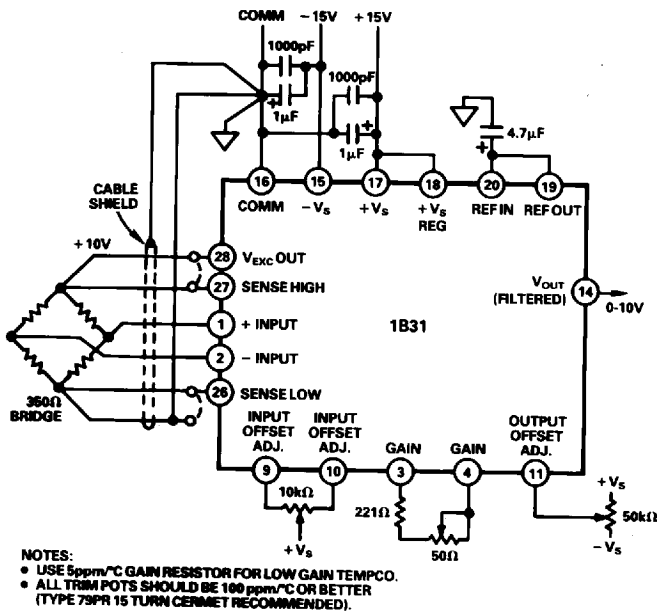

Figure 2. Typical Application

Input Offset Adjustment: To null input offset voltage, an optional 10kΩ potentiometer may be connected across the INPUT OFFSET ADJ. terminals (Pins 9 and 10 in Figure 2). With gain set at the desired value, connect both inputs (Pins 1 and 2) to COMMON (Pin 16), and adjust the 10kΩ potentiometer for zero volts at Pin 14. For applications using software nulling, Pins 9 and 10 should be left unconnected.

Output Offset Adjustment: The output can be offset over the ±10V range to compensate for dead load or bridge imbalance by using a 50kΩ potentiometer connected to Pin 11 as shown in Figure 2. Pin 11 is normally grounded if output offsetting is not desired.

Filter Cutoff Frequency Programming: The low pass filter cutoff frequency is internally set at 1kHz. It may be decreased from 1kHz by the addition of two external capacitors connected as shown in Figure 3 (from Pin 12 to common and between Pins 13 and 14). The values of capacitors required for a desired cutoff frequency, f_C, below 1kHz are obtained by the equations below:

$$C_{SEL1} = 0.015\mu F \left[\frac{1kHz}{f_C} - 1 \right]$$

$$C_{SEL2} = 0.0022\mu F \left[\frac{1kHz}{f_C} - 1 \right]$$

C_{SEL1} can be polarized for large values.

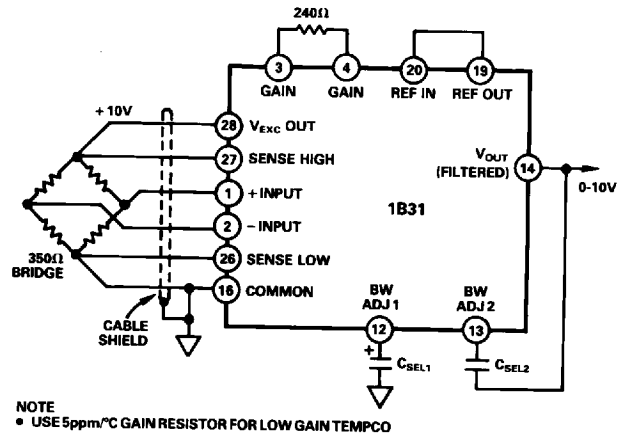

Figure 3. Narrow Bandwidth Application

The cutoff frequency may also be increased from 1kHz to 20kHz by the addition of three external resistors, connected as shown in Figure 4. The equations for determining the resistor values are:

$$R_{SEL1} = 20k\Omega / \left[\frac{f_C}{1kHz} - 1 \right]$$

$$R_{SEL2} = 16k\Omega / \left[\frac{f_C}{1kHz} - 1 \right]$$

$$R_{SEL3} = 40k\Omega / \left[\frac{f_C}{1kHz} - 1 \right]$$

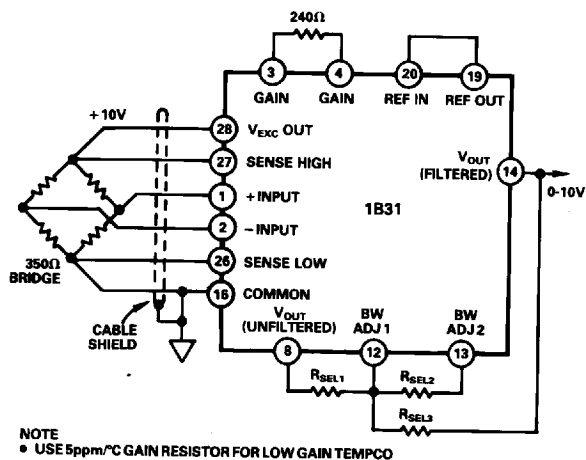

Figure 4. Wide Bandwidth Application

Table I gives the nearest resistor and capacitor values for several common filter cutoff frequencies.

f_c (Hz)	C_{SEL1} (μ F)	C_{SEL2} (μ F)	R_{SEL1} (k Ω)	R_{SEL2} (k Ω)	R_{SEL3} (k Ω)
10	1.5	0.2			
50	0.27	0.039			
100	0.15	0.02			
200	0.056	0.0082			
500	0.015	0.0022			
2000			20	16.2	40.2
5000			4.99	4.12	10.0
10000			2.21	1.78	4.42
20000			1.05	0.866	2.21

Table I. Filter Cutoff Frequency vs. R_{SEL} and C_{SEL}

Note: The 25MHz gain bandwidth product of the IA should be considered in high-gain, wide bandwidth configurations.

Voltage Excitation Programming: The excitation voltage is preset to +10V when Pin 19 is connected to Pin 20. To increase V_{EXC} up to +15V a resistor must be connected between EXC. ADJ. and SENSE LOW (Pins 21 and 26) as shown in Figure 5. For a desired V_{EXC} the resistor value, R_{EXT} , is determined by the following equations:

$$R_T = \frac{10k\Omega \times V_{REF OUT}}{V_{EXC} - V_{REF OUT}} ; V_{REF OUT} = +6.8V$$

$$R_{EXT} = \frac{20k\Omega \times R_T}{20k\Omega - R_T}$$

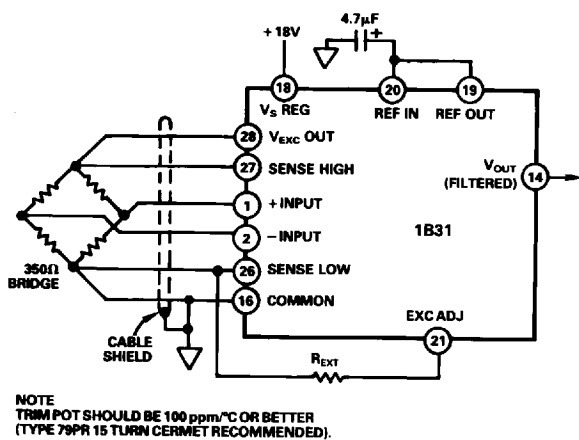

Figure 5. Increasing the Excitation Voltage: +10V to +15V Range.

To decrease V_{EXC} from +10V to +4V, a resistor has to be connected between REF IN and REF OUT (Pins 19 and 20) as shown in Figure 6. The equations to determine the value of R_{EXT} are:

$$V_{REF IN} = 0.68V_{EXC}$$

$$R_{EXT} = 10k\Omega \left[\frac{V_{REF OUT}}{V_{REF IN}} - 1 \right] ; V_{REF OUT} = +6.8V$$

A 20k Ω potentiometer between the REF IN and REF OUT pins will span the +4V to +10V excitation range. A 4.7 μ F tantalum capacitor from REF IN (Pin 20) to COMMON (Pin 16) is recommended in all cases to lower the voltage noise at the reference input.

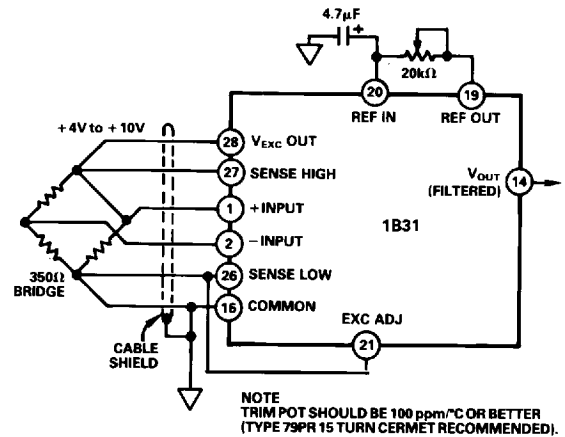

Figure 6. Decreasing the Excitation Voltage: +4V to +10V Range

The remote sensing inputs should be connected to the transducer separately from the excitation leads or jumpered as shown in Figure 2.

Power Supply Decoupling: The power supplies should be decoupled with 1 μ F tantalum and 1000pF ceramic capacitors as close to the 1B31 as possible (Figure 2).

Input Protection: The differential inputs of the 1B31 can be protected from accidental shorts to power line voltages (115V rms) by the circuit shown in Figure 7. The back-to-back diodes clamp the inputs to a maximum of $\pm 12.5V$ and were selected for low leakage current. The 15k Ω resistors in series with the inputs will degrade the noise performance of the 1B31 to 4.2 μ V p-p in a bandwidth of 0.1Hz to 1kHz. For six-wire load cells in harsh environments the additional protection for the sense inputs shown in Figure 7 is recommended.

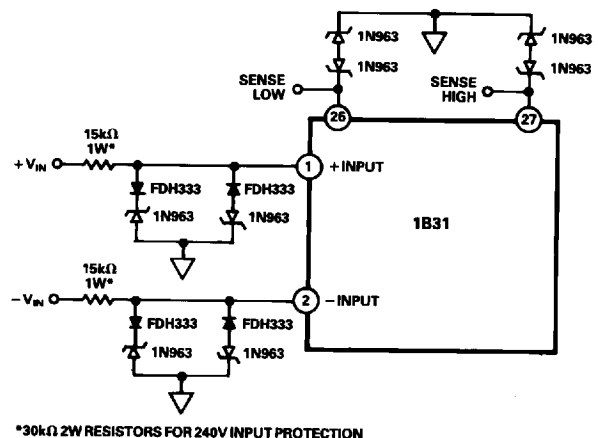

Figure 7. 115V Input Protection for 1B31

1B31

PERFORMANCE CHARACTERISTICS

Input Offset Voltage Drift: Total offset voltage drift is composed of input and output drifts and is a function of gain. The 1B31 typically exhibits $\pm 0.25\mu\text{V}/^\circ\text{C}$ RTI drift at a gain of 1000V/V over the full temperature range. The RTI voltage offset drift vs. gain is graphed in Figure 8.

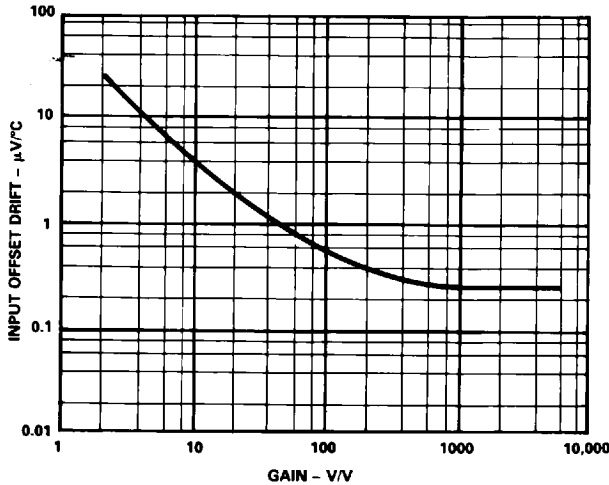

Figure 8. Total Input Offset Drift vs. Gain

Low Pass Filter: The two pole Butterworth filter is a multiple feedback design with a gain of $-2\text{V}/\text{V}$. It is preset at a cutoff frequency of 1kHz (-3dB) with a 40dB/decade roll-off. The step response at 1kHz is 1.5ms settling time to 0.1% of final value with less than 5% overshoot. The frequency response of the filter is shown graphically in Figure 9.

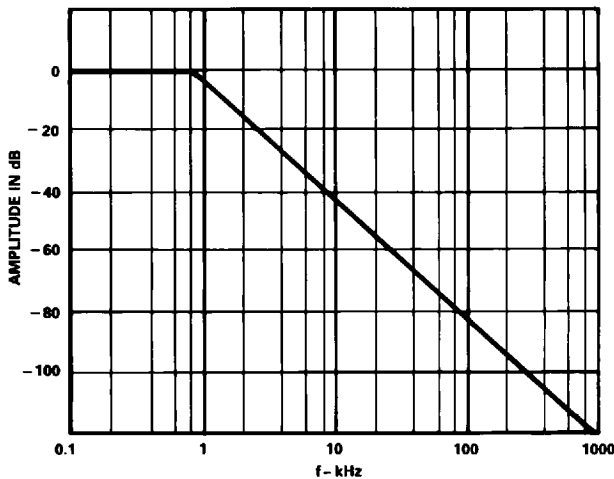
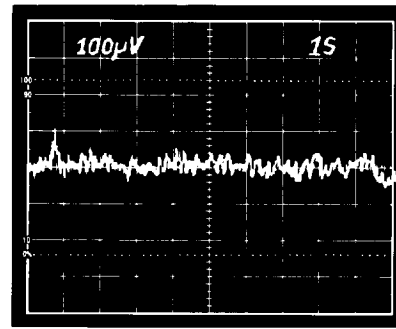
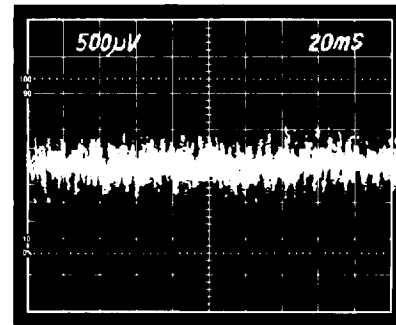

Figure 9. Filter Amplitude Response vs. Frequency

Gain Nonlinearity and Noise: Gain Nonlinearity is specified as a percent of full-scale output, and for the 1B31 it is $\pm 0.005\%$ maximum over the full-gain range. The IA design also offers exceptionally quiet performance with typical input noise of $0.3\mu\text{V}$ p-p for a 10Hz bandwidth (Figure 10a) and $1\mu\text{V}$ p-p for a 1kHz bandwidth (Figure 10b).



a. Bandwidth = 0.1Hz to 10Hz



b. Bandwidth = 0.1Hz to 1kHz

Figure 10. Voltage Noise, RTO @ $G = 1000\text{V}/\text{V}$

Common-Mode Rejection: CMR as a function of gain and frequency is shown in Figure 11. The best results (140dB @ 60Hz) are obtained by programming the low pass filter with a 10Hz cutoff frequency, which contributes an additional 30dB to the 1kHz specification where 60Hz noise is not attenuated by the filter.

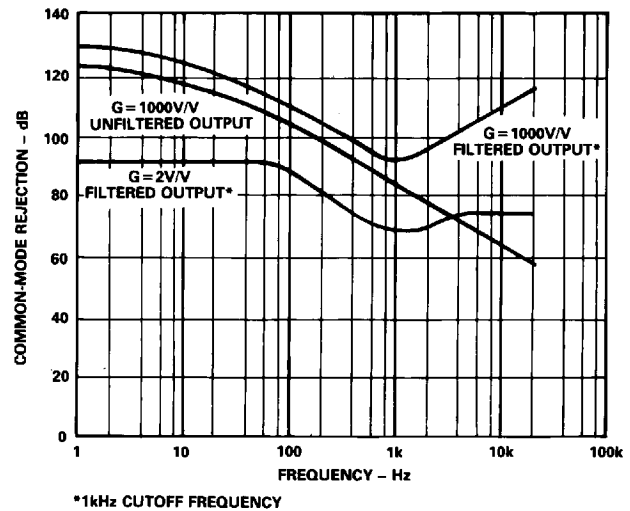

Figure 11. Common-Mode Rejection vs. Frequency and Gain

Turn On Drift: The input offset of the 1B31 stabilizes to within 1 μ V of final value in 5 minutes (Figure 12). The test conditions are: 350 Ω bridge with +10V excitation and ambient temperature of +25 $^{\circ}$ C.

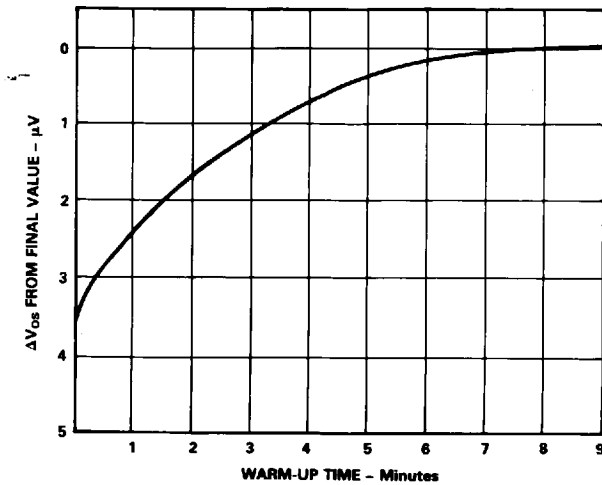

Figure 12. Offset Voltage, RTI, Turn-On Drift

Bridge Excitation: The adjustable bridge excitation is specified over a wide regulator input voltage range (+9.5V to +28V). Maximum load current I_L as a function of regulator input-output differential voltage is shown in Figure 13. The maximum output current also depends on ambient temperature and above 50 $^{\circ}$ C a derating factor should be derived from Figure 14.

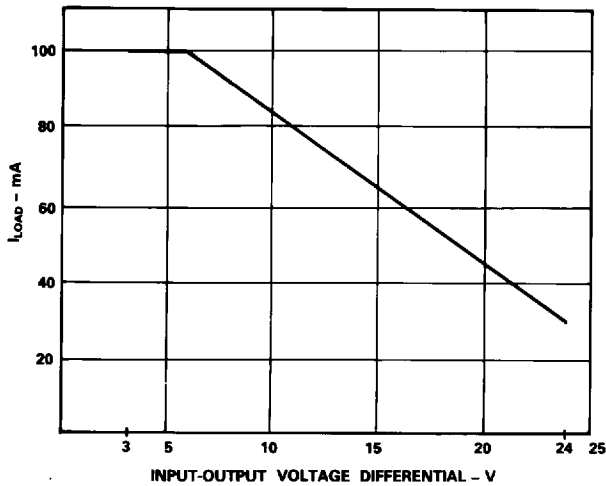

Figure 13. Excitation Source Input - Output Voltage Differential vs. Load Current; Ambient Temperature $\leq 25^{\circ}$ C.

APPLYING THE 1B31

Strain Measurement: The 1B31 is shown in a strain measurement system in Figure 15. A single active gage (120 Ω , Gage Factor = 2) is used in a bridge configuration to detect fractional changes in gage resistance caused by strain. An equivalent resistance

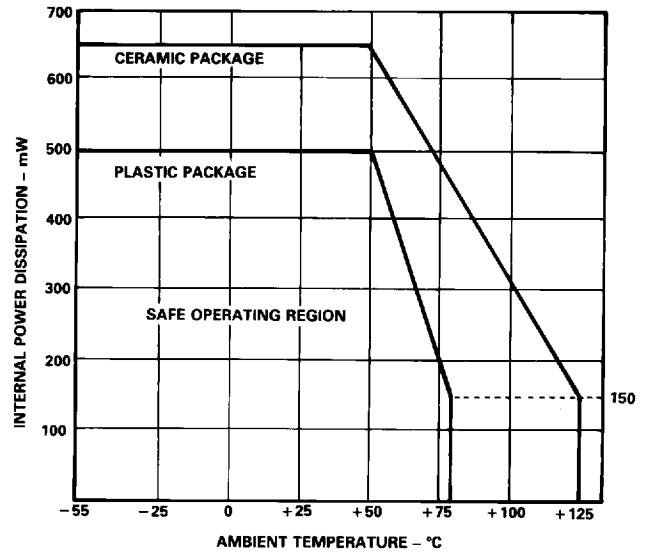

Figure 14. Excitation Source Internal Power Dissipation vs. Temperature

dummy gage mounted adjacent to the active gage provides temperature compensation. The rest of the bridge is completed by the 1B31 internal half-bridge network which consists of two 20k Ω , 1% thin-film resistors tracking to within ± 5 ppm/ $^{\circ}$ C max. Bridge excitation is set at +4V to avoid self-heating errors from the strain gage. System calibration produces a +1V output for an input of 1000 microstrains. The filter cutoff frequency is set at approximately 100Hz.

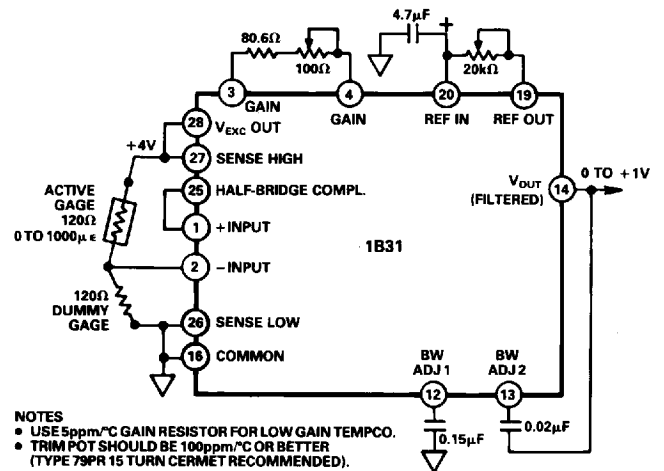

Figure 15. Strain Gage Application Using Internal Half-Bridge

Pressure Transducer Interface: A strain gage type pressure transducer (Dynisco 800 series) is interfaced to a 1B31 in Figure 16. Regulated excitation of +10V dc is provided for a 30mV full-scale output. The gain is sett at 333.3 to achieve a 0-10V output for a 0-10,000 psi range of the transducer. A shunt calibration resistor is built into the transducer for easy verification of the 80%-point of its full-scale output. A typical shielding scheme to preserve the excellent performance characteristics of the 1B31 is also shown. To avoid ground loops, signal return or cable shield should be grounded only at one point.

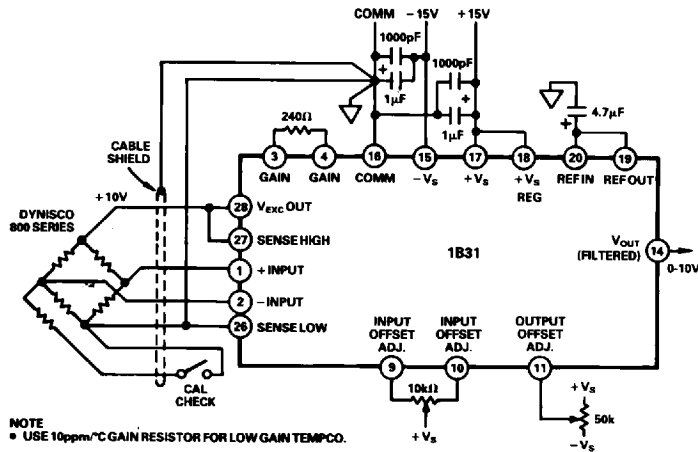

Figure 16. Pressure Transducer Application

Multiple Load-Cells: For transducer configurations where the maximum load current of 100mA of the 1B31 is not sufficient, a buffer and a power transistor such as a TIP31 can be used as shown in Figure 17. This design can supply 300mA at +10V excitation over the full industrial temperature range (-25°C to +85°C). In a multiple 1B31 system an added advantage is that ratiometric operation can be preserved by using one excitation source which also serves as the reference voltage for the system A/D converter.

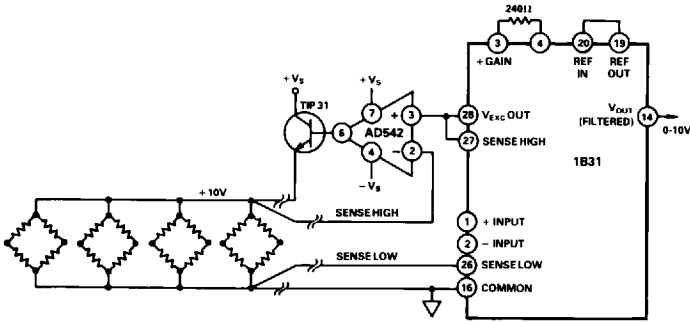

Figure 17. Multiple Load-Cell Application

Mobile Transducer Application: The small size and reliability of the 1B31 make it an ideal choice for mobile applications. Since the 1B31 requires a negative supply, one possible solution for its generation is shown in Figure 18. The positive voltage of a +12V battery is used to drive a CMOS TLC555 oscillator with a typical supply current of 360μA. The output is a square wave that is rectified by the diodes and filtered to provide a -9V supply. Excitation voltage should be equal to or less than +9V for adequate headroom for the 1B31 voltage regulator.

Pressure Transducer Data Acquisition System: Figure 19 shows a two module solution for microcomputer based data acquisition using a 1B31 and an AD1170 18-bit A/D converter. A 3mV/V pressure transducer (e.g. Dynisco 800 series) is interfaced to a 1B31 set up with a gain of 333.3 to give a 0 - 5V output. The regulated excitation is +5V, and for ratiometric operation it is also used as the voltage reference input for the AD1170. An initial ECAL command establishes the voltage excitation as the full-scale input of the AD1170 and periodic calibration cycles keep the converter tracking the reference input. This configuration yields very high CMR (168dB @ 60Hz) enhanced by the 1B31 low pass filter and the integrating conversion scheme of the

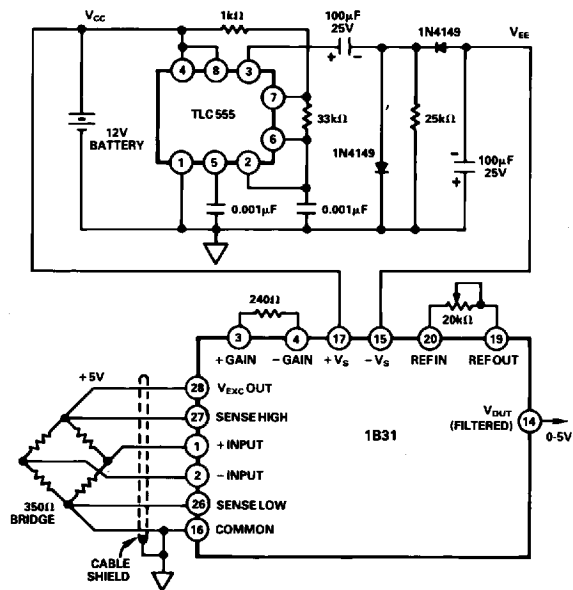

Figure 18. Negative Supply Generation for 1B31

AD1170. In addition, fixed offsets caused by bridge imbalance can be nulled out by the AD1170 with a power-up initialization command from the microcomputer. This eliminates a potentiometer or software overhead which might otherwise be needed.

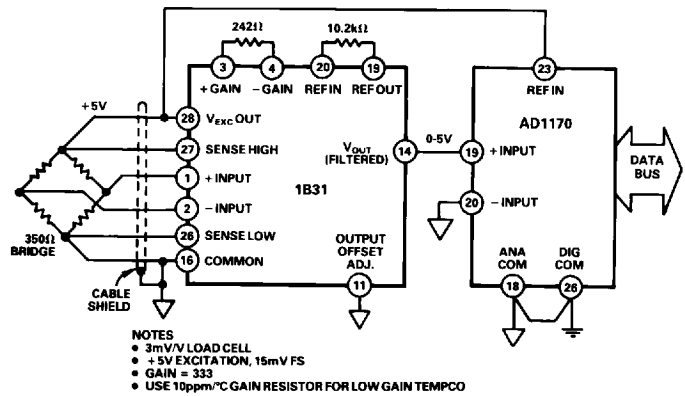

Figure 19. Pressure Transducer Data Acquisition Using 1B31 and AD1170

Isolated Current Loop Interface: The output of the 1B31 can be interfaced to a process loop as shown in Figure 20. The 2B23 module produces an isolated 4-to-20mA output current which is proportional to the input voltage and independent of the output load resistance. Common-mode input/output isolation is ±1500V pk continuous.

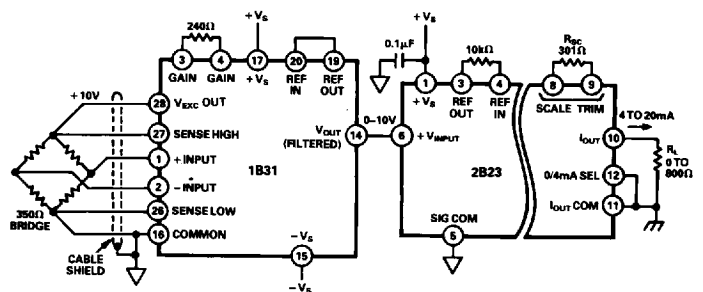

Figure 20. Isolated 4-20mA Transmitter