



SPECIFICATION FOR APPROVAL

Customer : STD

Description : DC BLOWER

Customer Part No. _____ REV. : _____

Delta Model No. : BFN0724SS-01 REV. : 04

Sample Issue No. : _____

Sample Issue Date : MAY.25 2020

PLEASE SEND ONE COPY OF THIS SPECIFICATION BACK AFTER YOU SIGNED APPROVAL FOR PRODUCTION PRE-ARRANGMENT.

APPROVED BY:

DATE :

DELTA ELECTRONICS, INC.
TAOYUAN PLANT
252, SHANGYING ROAD, GUIZHAN INDUSTRIAL
TAOYUAN CITY 33341, TAIWAN
TEL:886-(0)3-3591968
FAX:886-(0)3-3591991

DELTA ELECTRONICS, INC.
252, SHANGYING ROAD, GUISHAN INDUSTRIAL ZONE,
TAOYUAN CITY 33341, TAIWAN

TEL : 886-(0)3-3591968
FAX : 886-(0)3-3591991

STATEMENT OF DEVIATION

- NONE
- DESCRIPTION:

DELTA ELECTRONICS, INC.
 252, SHANGYING ROAD, GUISHAN INDUSTRIAL ZONE,
 TAOYUAN CITY 33341, TAIWAN

TEL : 886-(0)3-3591968
 FAX : 886-(0)3-3591991

Specification For Approval

Customer : STD

Description : DC BLOWER

Customer P/N :

rev. :

Delta model no. : BFN0724SS-01

Delta Safety Model No.: BFN0724SS-01

Sample revision. : 04

Issue no.:

Sample issue date : MAY.25 2020

Quantity :

1. SCOPE:

THIS SPECIFICATION DEFINES THE ELECTRICAL AND MECHANICAL CHARACTERISTICS OF THE DC BRUSHLESS BLOWER.

2. CHARACTERS:

GENERAL BLOWER SPECIFIC DATA (UN-CONTROLLED OPERATION, ALL READINGS ARE MEASUREDAFTER STABLY WARMING UP THROUGH 10 MINUTES) ⓘ

ITEM	DESCRIPTION
MOTOR TYPE	BLDC 3PHASE / 6PULSE/4POLE
RATED VOLTAGE	24V
INPUT CURRENT (FREE AIR)(AVG)★	1.50 (MAX. 1.80) A (SAFETY CURRENT ON LABEL : N/A)
INPUT POWER(AVG)★	36.0 (MAX. 43.2) W
SPEED (FREE AIR)	31500±10% R.P.M.
SPEED (MAX. STATIC PRESSURE)	36000±10% R.P.M.
MAX. AIR FLOW (AT ZERO STATIC PRESSURE)	511.407 (MIN. 460.266) L/MIN 18.06 (MIN. 16.25) CFM
MAX. AIR PRESSURE (AT ZERO AIRFLOW)	49.936 (MIN. 40.443) cmH ₂ O 19.66 (MIN. 15.92) inchH ₂ O
① LIFE EXPECTANCE (L10) (AT LABEL VOLTAGE)	15,000 HOURS CONTINUOUS OPERATION AT 25 °C WITH 15 ~ 65 %RH.
ROTATION	COUNTERCLOCKWISE (VIEW FROM INLET PLATE SIDE)

★AVG. IS THE AVERAGE VALUE DURING STEADY OPERATION, AND MAX. IS MAXIMUM AVERAGE VALUE INCLUDED RODUCTION TOLERANCE. ABOUT THE PEAK VALUE, NEED TO USE OSCILLOSCOPE TO MEASURE.

①All CHARACTERS DEFINED BY DELTA CONTROLL BOARD (DELTA P/N: FC241B7-L0E)

(continued)

PART NO:

DELTA MODEL: BFN0724SS-01

OPERATING POINT 1 BLOWER SPECIFIC DATA

RATED VOLTAGE	24 VDC
MAX. CURRENT	MAX. 0.65 A
NOMINAL SPEED	17300 RPM
②NOMINAL AIR FLOW (WITH 4MM NOZZLE,WITHOUT AIR INLET)	23.7 ± 2.5% LPM
NOMINAL BACK PRESSURE (WITH NOMINAL SPEED AND NOMINAL AIR FLOW)	1000 ± 8% Pa
③ACOUSTICAL NOISE BLOWER PLACE ON 1mm THICK RUBBER PLATE AND 10cm THICK FOAM MATERIAL. THE INLET AND OUTLET OF BLOWER ARE BLOCKED. MICROFONE IN 0.5M DISTANCE ABOVE THE CENTER ON THE PLUG SIDE AT NOMINAL SPEED OF ABOUT 17300RPM.	38.0 (MAX.42.0) dBA

- ① LIFE TEST CONDITION IS AT FREE AIR 23000RPM (REF.)
- ② AIR FLOW MEASUREMENT CAN BE REFER TO FIG.A
- ③ REFER TO ACOUSTICAL NOISE MEASURING CONDITION SHOWN IN PAGE 3.

NOTES:

1. ALL READINGS ARE MEASURED AFTER STABLY WARMING UP THROUGH 10 MINUTES.
2. STANDARD AIR PROPERTY IS AIR AT (Td) 25°C TEMPERATURE, (RH) 65% RELATIVE HUMIDITY, AND (Pb) 760 mmHg BAROMETRIC PRESSURE.
3. THE VALUES WRITTEN IN PARENS , (), ARE LIMITED SPEC.
4. FAN DATA WITH CONTROLL BOARD (DELTA P/N: FC241B7-L0E)

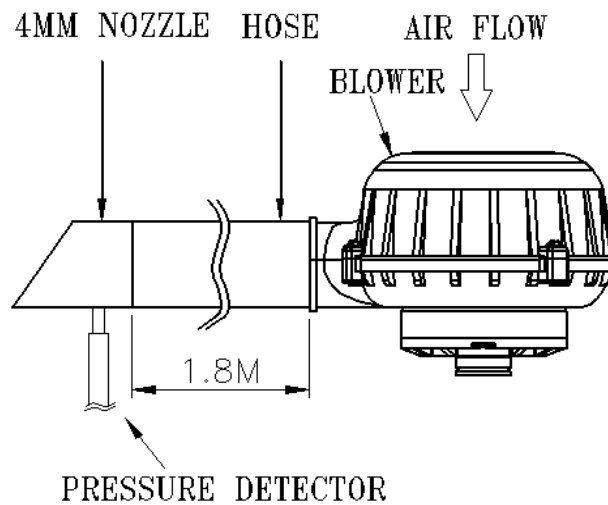
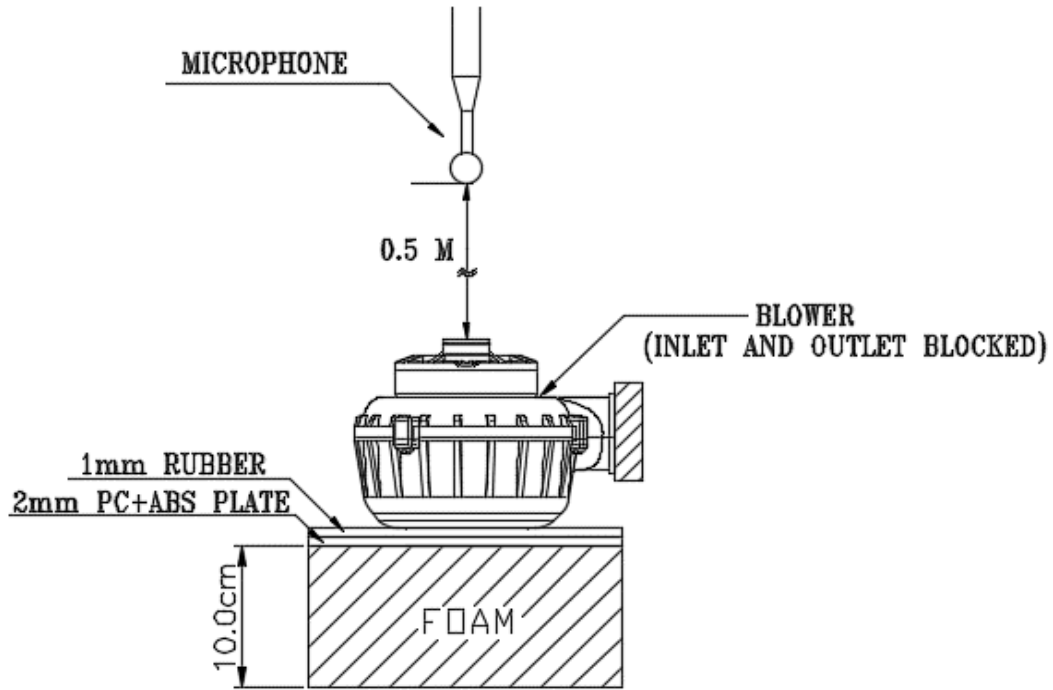

FIG.A

PART NO:

DELTA MODEL: BFN0724SS-01

ACOUSTICAL NOISE MEASURING CONDITION:



NOISE IS MEASURED AT RATED VOLTAGE WITH ABOVE SETUP IN ANECHOIC CHAMBER WITH MICROPHONE AT A DISTANCE OF 0.5 METER FROM THE FAN PLUG.

PART NO:

DELTA MODEL: BFN0724SS-01

3. MECHANICAL:

- 3-1. DIMENSIONS----- SEE DIMENSIONS DRAWING
- 3-2. FRAME----- PLASTIC
- 3-3. IMPELLER----- PLASTIC
- 3-4. BEARING SYSTEM----- TWO BALL BEARINGS
- 3-5. WEIGHT----- 230 GRAMS(REF.)

4. ENVIRONMENTAL:

- 4-1. OPERATING TEMPERATURE----- 10 TO +40 DEGREE C
- 4-2. STORAGE TEMPERATURE----- 10 TO +70 DEGREE C
- 4-3. OPERATING HUMIDITY----- 5 TO 90 % RH
- 4-4. STORAGE HUMIDITY----- 5 TO 95 % RH

5. RE OZONE DEPLETING SUBSTANCES:

- 5-1. NO CONTAINING PBBs, PBBOs, CFCs, PBBEs, PBDPEs AND HCFCs.

6. PRODUCTION LOCATION

- 6-1. PRODUCTS WILL BE PRODUCED IN CHINA

PART NO:

DELTA MODEL: BFN0724SS-01

7. P & Q CURVE:

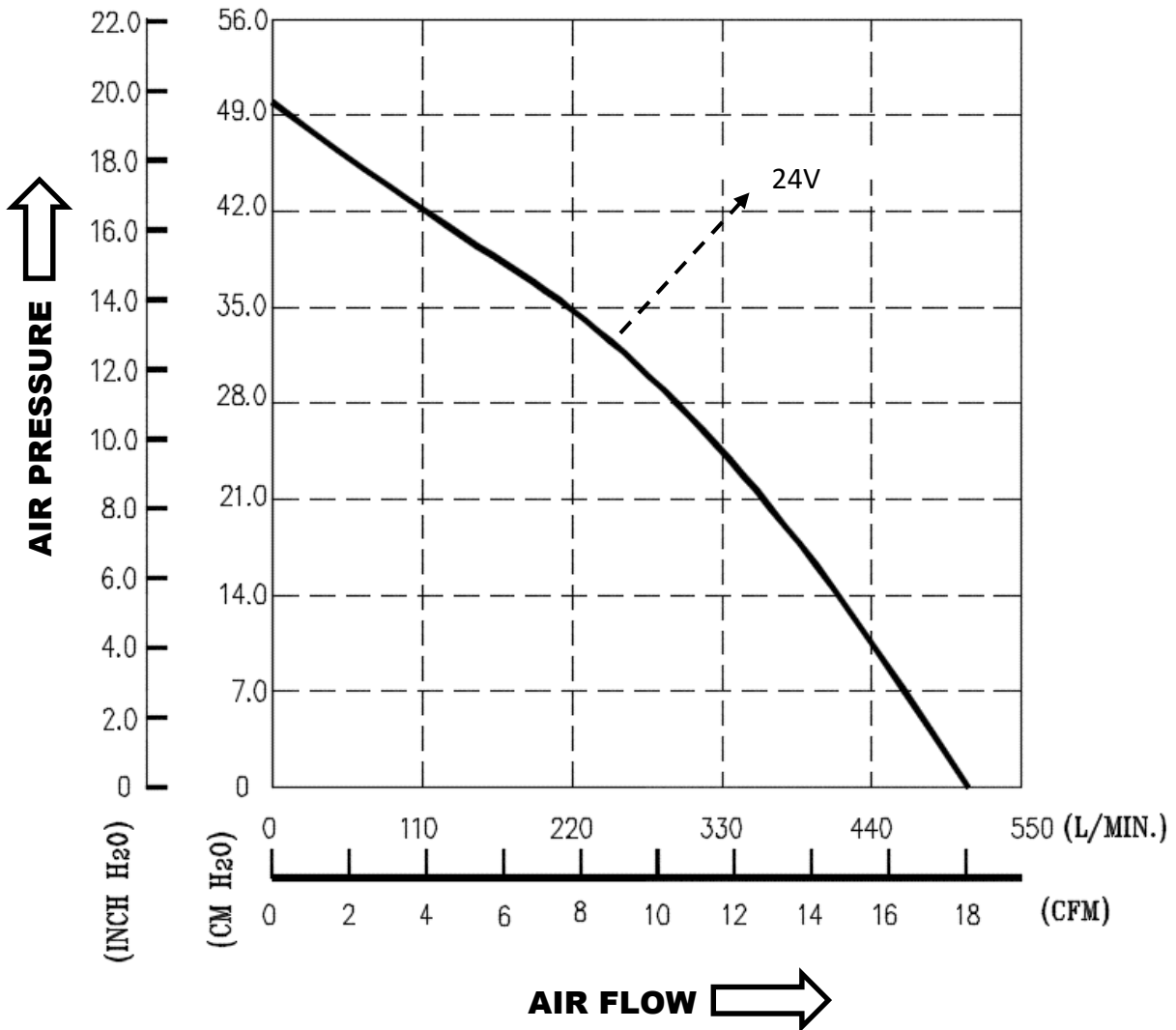

① All CHARACTERS DEFINED BY DELTA CONTROL BOARD (DELTA P/N: FC241B7-L0E)

*TEST CONDITION: INPUT VOLTAGE-----OPERATION VOLTAGE
TEMPERATURE-----ROOM TEMPERATURE
HUMIDITY-----65%RH

PART NO:

DELTA MODEL: BFN0724SS-01

8. DIMENSION DRAWING:

LABEL:

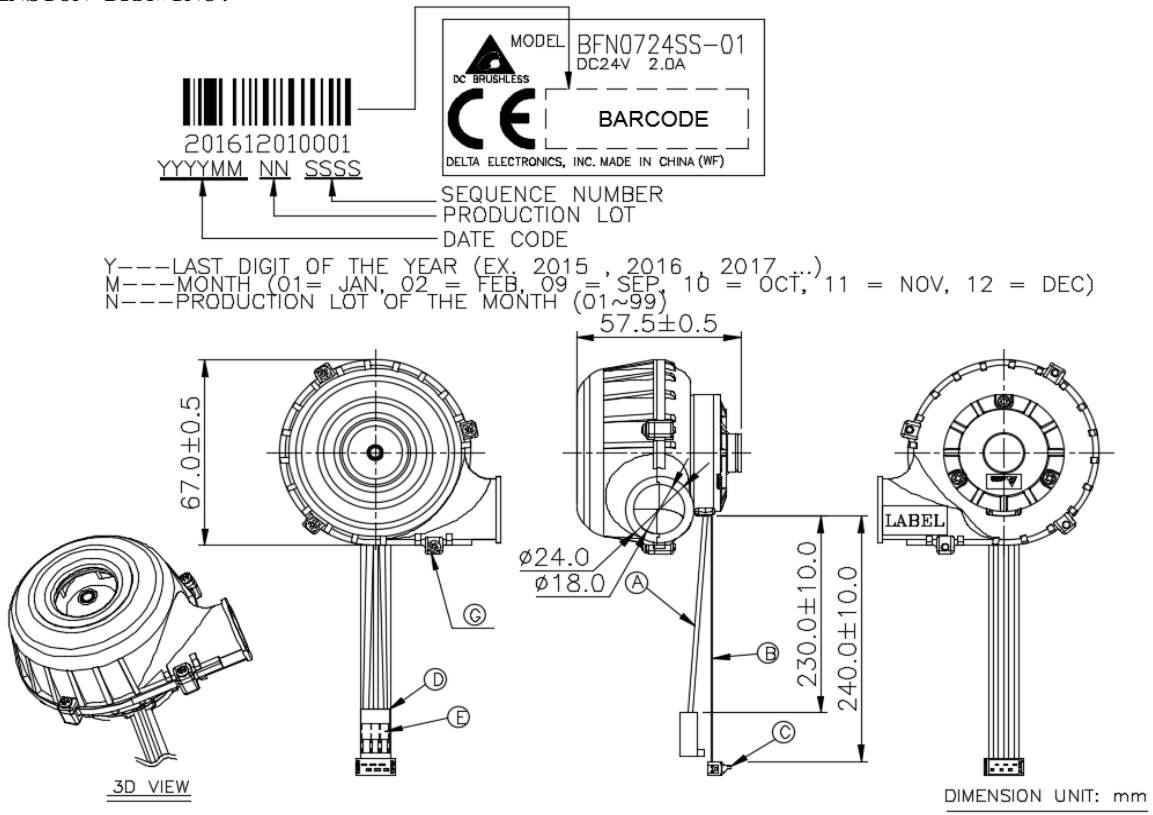

NOTES: A. LEAD WIRE: UL3266 AWG22

- PIN 1: BLACK WIRE
- PIN 2: RED WIRE
- PIN 3: BLUE WIRE



CONNECTOR ASSIFMENT	COLOUR	FUNCTION
1	BLACK	V
2	RED	W
3	BLUE	U

B. LEAD WIRE: CIRCUITS FLAT RIBBON CABLE UL2651 AWG#28

- PIN 1: RED WIRE
- PIN 2: GRAY WIRE
- PIN 3: GRAY WIRE
- PIN 4: GRAY WIRE
- PIN 5: GRAY WIRE
- PIN 6: GRAY WIRE

CONNECTOR ASSIFMENT	FUNCTION
1	HALL 1
2	GND
3	NTC (F)
4	+UH
5	HALL 2
6	HALL 3

C. HOUSING: AMP MICROMATCH 215083-6

D. HOUSING: MOLEX 22-01-3037

E. TERMINAL: MOLEX 08-50-0113

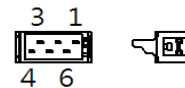

- ★ F. NTC 100K CONECTED TO GND P/N:NB12P00104JBB OR TSM2A104H4223RZA (REFER APPENDIX FOR THERMISTOR CHARACTERISTIC)
- G. SCREW M2.5X10---4PCS (TIGHTENING TORQUE 2.5kg-cm)
- H. THIS PRODUCT IS RoHS COMPLIANT

PART NO:

DELTA MODEL: BFN0724SS-01

9. MOTOR PHASE SCEQUENCE:

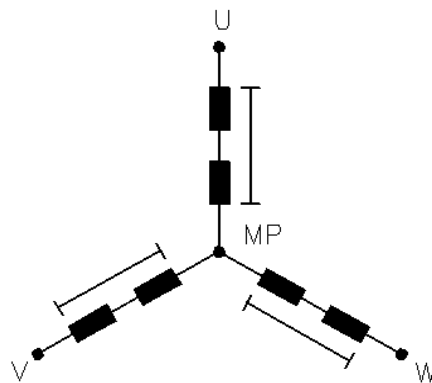
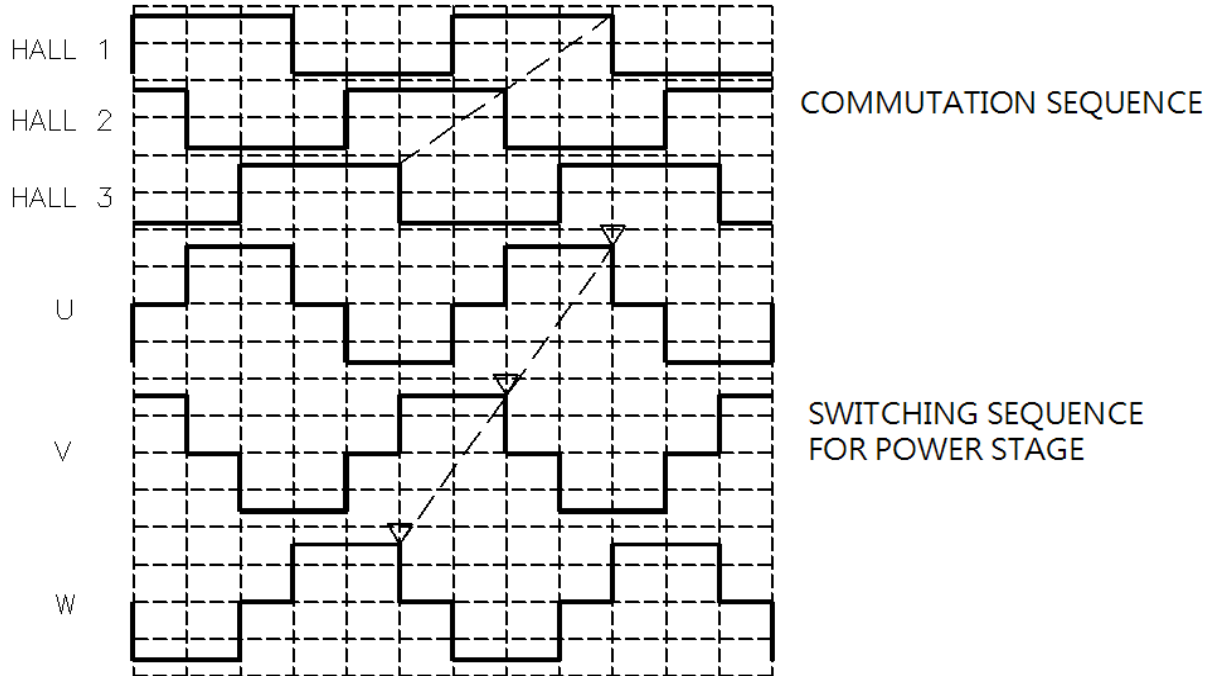

PART NO:

DELTA MODEL: BFN0724SS-01

10. MOTOR DATA:

MOTOR TYPE	BLDC 3 PHASE/6PULSE/4POLE
SENSOR SUPPLY RANGE	4.5-24 V
SENSOR SUPPLY CHARGING RATE	24@V _{cc} =12V
SENSOR OUTPUT	U _{DS(SAT)} <=0.5V, I _{DMAX} =20mA (OPEN DRAIN)
MOTOR DATA WITH CONTROLL BOARD	CONTROLL BOARD P/N:FC241B7-L0E
NOMINAL SUPPLY VOLTAGE	24V
NOMINAL SPEED	30000 ±15% RPM
NOMINAL TORQUE	10 mNm
NOMINAL CURRENT	1.8±15% A
NOMINAL OUTPUT POWER	32.0 W
NO-LOAD SPEED	38000±15% RPM
NO-LOAD CURRENT	0.20±25% A
MAX. PERMISSIBLE STARTING TORQUE	50 mNm
MAX. PERMISSIBLE STARTING CURRENT	7.5 A
INDUCED VOLTAGE	0.63±7% V/1000min ⁻¹
TERMINAL INDUCTANCE(AT 1KHz , 1V)	0.22±15% mH
TERMINAL RESISTANCE	1.98 ±10% Ω
DIRECTION ROTATION	CCW
OPERATING TEMPERATURE RANGE	0~40 °C
MASS	0.200±10% Kg
ROTOR INTERIA	1.183 X 10 ⁻⁶ Kgm ²
INSTALLATION ABOVE SEA LEVEL	<1000M
INSULATION CLASS	E
INSULATION RESISTANCE	500V _{DC} > 1MΩ
ELECTRIC STRENGTH OF WINDING	>550VAC
AIR-AND CREEPAGE DISTANCE	DEGREE OF POLLUTION 2
DEGREE OF PROTECTION	IP20
ALL NOMINAL DATA ARE RELATED TO AMBIENT TEMPERATURE T=23°C AND WARMED UP MOTOR.	

PART NO:

DELTA MODEL: BFN0724SS-01

APPENDIX.

TABLE1 SHOWS THE RELATIONSHIP BETWEEN TEMPERATURE AND RESISTANCE.

1. AVX: NB12P00104JBB
2. THINKING: TSM2A104H4223RZA

TABLE1 THERMISTOR CHARACTERISTIC

T°C	R Nom (Ω)	Tol. (± %)	T°C	R Nom (Ω)	Tol. (± %)
-40	4072416	20,8	60	22814	8,6
-35	2895177	18,4	65	18895	9,3
-30	2080373	16,3	70	15729	10,0
-25	1510332	14,4	75	13158	10,7
-20	1107387	12,8	80	11058	11,4
-15	819709	11,3	85	9337	12,1
-10	612348	10,1	90	7918	12,9
-5	461493	9,0	95	6743	13,6
0	350768	8,0	100	5766	14,4
5	268797	7,2	105	4950	15,2
10	207610	6,5	110	4266	15,9
15	161571	5,9	115	3691	16,7
20	126664	5,4	120	3204	17,5
25	100000	5,0	125	2791	18,3
30	79486	5,4			
35	63595	5,8			
40	51202	6,3			
45	41476	6,8			
50	33794	7,4			
55	27691	8,0			



Application Notice

- 1. Delta will not guarantee the performance of the products if the application condition falls outside the parameters set forth in the specification.**
- 2. A written request should be submitted to Delta prior to approval if deviation from this specification is required.**
- 3. Please exercise caution when handling fans. Damage may be caused when pressure is applied to the impeller, if the fans are handled by the lead wires, or if the fan was hard-dropped to the production floor.**
- 4. Except as pertains to some special designs, there is no guarantee that the products will be free from any such safety problems or failures as caused by the introduction of powder, droplets of water or encroachment of insect into the hub.**
- 5. The above-mentioned conditions are representative of some unique examples and viewed as the first point of reference prior to all other information.**
- 6. It is very important to establish the correct polarity before connecting the fan to the power source. Positive (+) and Negative (-). Damage may be caused to the fans if connection is with reverse polarity, if there is no foolproof method to protect against such error specifically mentioned in this spec.**
- 7. Delta fans without special protection are not suitable where any corrosive fluids are introduced to their environment.**
- 8. Please ensure all fans are stored according to the storage temperature limits specified. Do not store fans in a high humidity environment. We highly recommend performance testing is conducted before shipping, if the fans have been stored over 6 months.**
- 9. Not all fans are provided with the Lock Rotor Protection feature. If you impair the rotation of the impeller for the fans that do not have this function, the performance of those fans will lead to failure.**
- 10. Please be cautious when mounting the fan. Incorrect mounting of fans may cause excess resonance, vibration and subsequent noise.**
- 11. It is important to consider safety when testing the fans. A suitable fan guard should be fitted to the fan to guard against any potential for personal injury.**
- 12. Except where specifically stated, all tests are carried out at room (ambient) temperature and relative humidity conditions of 25°C, 65% RH. The test value is only for fan performance itself.**
- 13. Be certain to connect an “ 4.7μF or greater” capacitor to the fan externally when the application calls for using multiple fans in parallel, to avoid any unstable power.**
- 14. If the product is used with medical related field or other types of equipment that affect people's lives, advanced preparation of safety-related evaluations is mandatory.**
- 15. It should be avoided that product is using or storing in the environment, such as strong shocks, magnetic or electromagnetic noise, and which the electromagnetic noise overlaps into power voltage. This might cause the product breakdown or abnormal operation.**
- 16. Do not use the product in a flammable gas environment or explosive dust environment.**
- 17. If the product is used in extremely high reliable environment, such as medical/military equipment or other application. Please consult with Delta Electronics, Inc. before adopting in these applications.**