

THIS DRAWING IS UNPUBLISHED. RELEASED FOR PUBLICATION
 © COPYRIGHT BY TYCO ELECTRONICS CORPORATION. ALL RIGHTS RESERVED.

LOC		DIST		REVISIONS			
P	LTR	DESCRIPTION		DATE	DWN	APVD	
	B	REVISED PER ECO-07-029260		1/22/08	SS	MW	

NOTES:

1. ALL COLORS AND MATERIALS MADE FROM ONE TOOL.
2. SOME DIMENSIONS MAY VARY DUE TO DIFFERENT COMPOUND SHRINKAGE FACTOR.
3. MINOR FLASH ACCEPTABLE ON INSERT THREAD.
4. BLACK FINISH/NICKEL PLATING ON INSIDE THREADS REMOVED DUE TO MOLDING PROCESS PERMITTED.
5. RUBBER TO METAL BOND MUST MEET OR EXCEED THE TEAR STRENGTH OF RUBBER.
6. RUBBER OVERLAY PERMISSIBLE OVER HEX FLATS AS SHOWN IN THE DRAWING.
7. COMPONENTS MUST COMPLY WITH THE EUROPEAN DIRECTIVE 2002/95/EC ON RESTRICTION OF THE USE OF CERTAIN HAZARDOUS SUBSTANCES IN ELECTRICAL AND ELECTRONIC EQUIPMENT (ROHS DIRECTIVE).

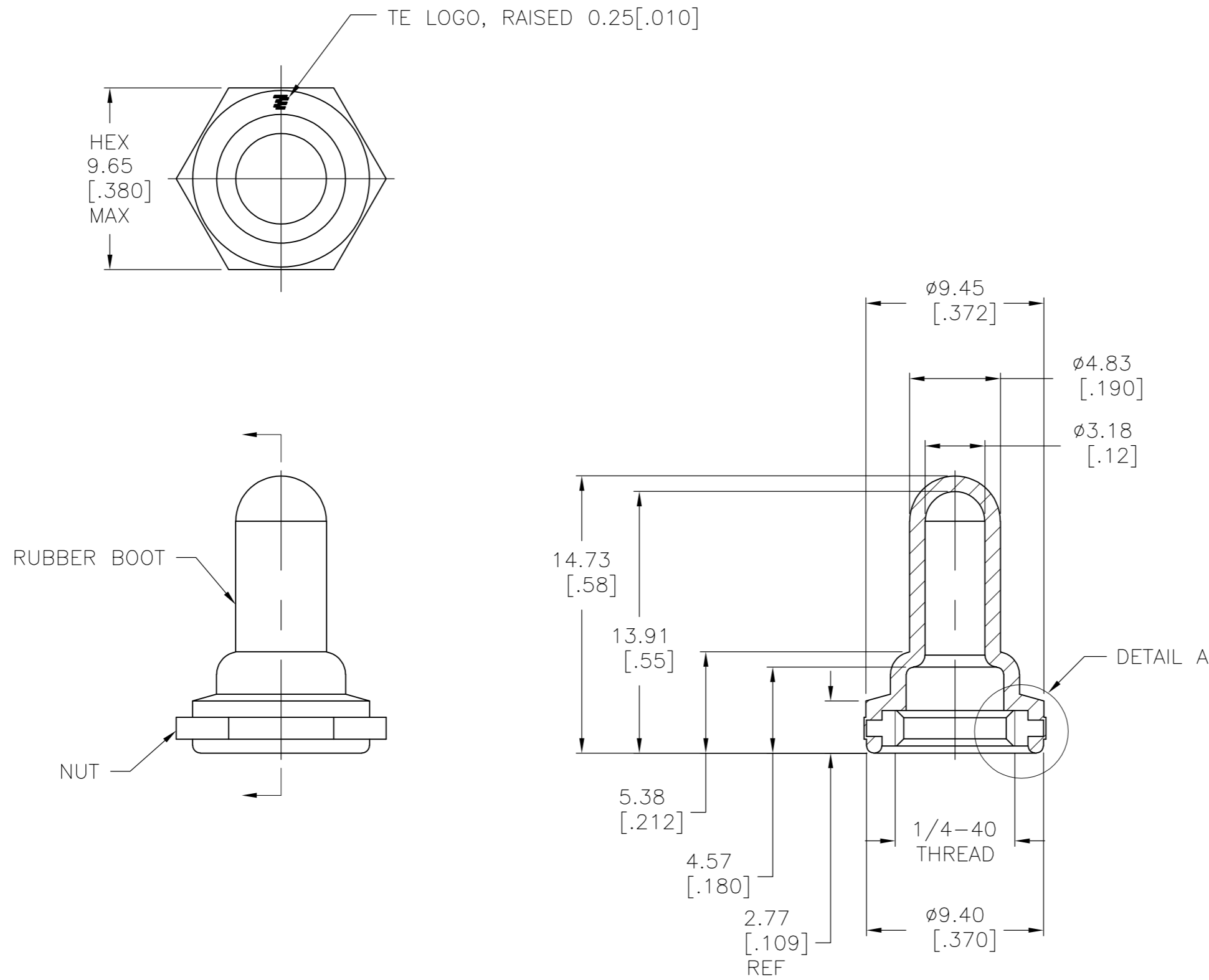

SILICONE, COLOR: GRAY	BRASS, NICKEL PLATE PER QQ-N-290	B1440804	1825612-3
SILICONE, COLOR: RED	BRASS, NICKEL PLATE PER QQ-N-290	B1440204	1825612-2
SILICONE, COLOR: BLACK	BRASS, BLACK OXIDE PER MIL-F-495	B1440004	1825612-1
RUBBER BOOT MATERIAL	HEX NUT MATERIAL	ALCO NUMBER	PART NUMBER

THIS DRAWING IS A CONTROLLED DOCUMENT.		DWN	S SCHLEGEL	22JAN2008	Tyco Electronics Corporation Harrisburg, PA 17105-3608		
DIMENSIONS: mm [INCHES]		CHK	M WILBOURN	1/22/08	NAME 1/4-40 TOGGLE SWITCH BOOT SEAL		
TOLERANCES UNLESS OTHERWISE SPECIFIED: 0 PLC ± - 1 PLC ± - 2 PLC ± .01 3 PLC ± .005 4 PLC ± - ANGLES ± 5°		APVD	M WILBOURN	1/22/08	SIZE	CAGE CODE	DRAWING NO
MATERIAL		FINISH	WEIGHT	-	A2	00779	1825612
		RESTRICTED TO	CUSTOMER DRAWING		SCALE	SHEET	REV
					4:1	1 of 1	B