

PART NAME: KNOB SCALE: 1:1 DATE: 6/6/96 DR. BY HD

THIS DRAWING IS THE PROPERTY OF DAVIES MOLDING COMPANY, IS SUBMITTED SOLELY AS A DESIGN OR ENGINEERING PROJECT. WE ACCEPT NO RESPONSIBILITY WHATSOEVER FOR THE PRACTICAL APPLICATION OF THE PIECES MADE TO THIS DESIGN.



DESIGNERS & MANUFACTURERS OF KNOBS, HANDLES, CASES & CUSTOM PLASTIC COMPONENTS

P/N 1214BL

BASE PART	1214-01
SET SCREW	I0357
INLAY	I0791SD

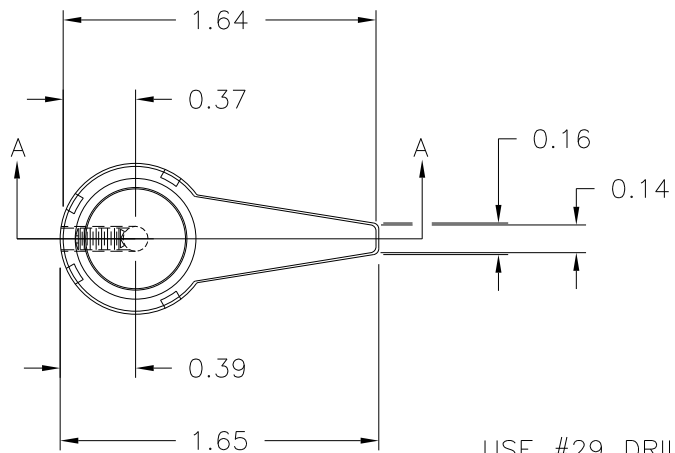

SECTION A-A

USE #29 DRILL, 8-32 TAP
8-32 THREAD X 1/4 LG. CUP POINT, HEADLESS, SLOTTED SET SCREW I0357, (1) REQ'D

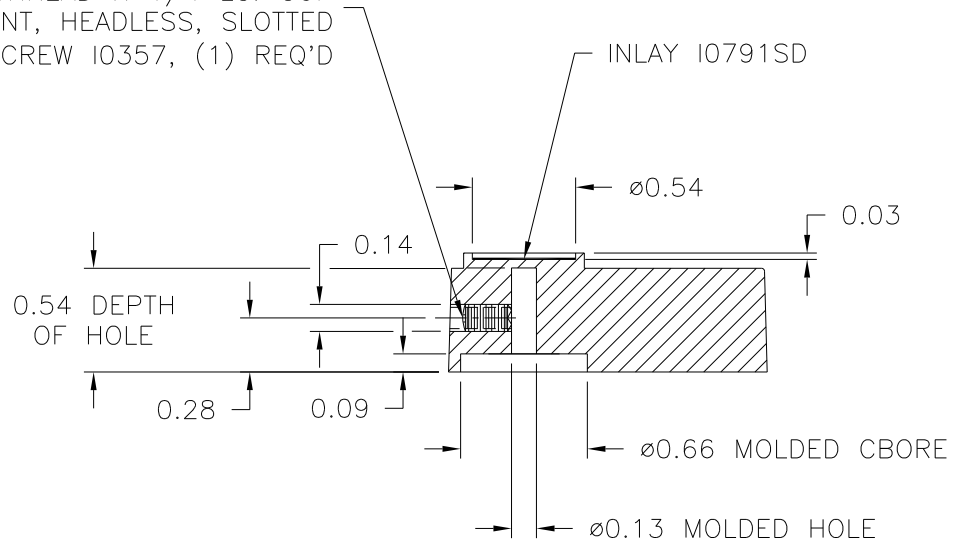
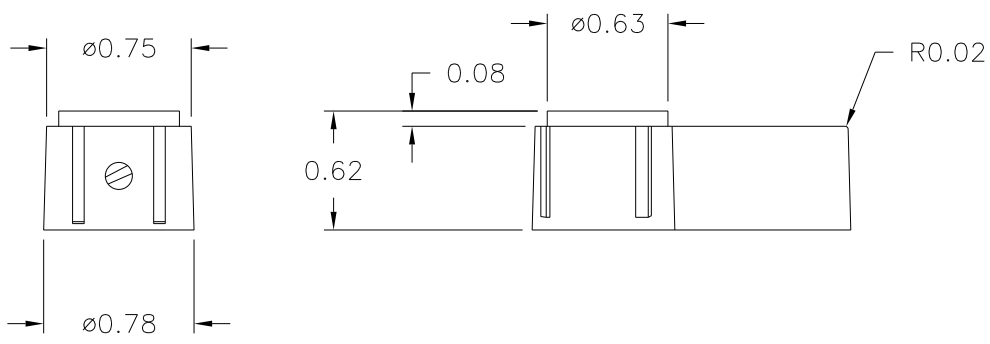

MATERIAL: G.P. PHENOLIC (B11)
COLOR: BLACK

TOLERANCES: UNLESS OTHERWISE SPECIFIED	DO NOT SCALE DRAWING				
DECIMALS: X.XXX ± .005 X.XX ± .015	MM: X.XX ± 0.15MM X.X ± 0.4MM	A	UPDATED TOOLBOX	LS	7/29/03
FRACTIONS ± 1/64	ANG. ± 1°	CHANGES			