

24 V ADR Switch Demonstrator

Board User Manual



About this document

Scope and purpose

This Board User Manual provides a short introduction into the 24 V ADR Switch Demonstrator and its application.

Intended audience

Electrical engineers who are qualified and familiar with the challenges of handling high current circuits.

Note: The 24 V ADR Switch Demonstrator is only intended to be used as an engineering demonstrator. It is not intended for extensive use or to be re-used in a product or system that is sold to consumers.

Table of contents

About this document	1
Table of contents	2
1 Overview	3
2 Connecting the Switch	5
2.1 Overview	5
2.2 Control	6
2.2.1 Pin Assignment.....	6
2.2.2 Input Voltage Range	7
2.2.3 Control with bistable relay adaptor	8
3 Operating Range	9
3.1 Voltage Range	9
3.2 Current Rating	9
4 Thermal Behavior	10
5 Switching Behaviour	11
6 Mechanical Dimensions	12
7 Schematics	13
8 PCB Description	16
8.1 PCB Technology	16
8.2 PCB Layout	17
9 Bill Of Materials	18
Revision History	19

1 Overview

The 24 V ADR Switch Demonstrator shows a semiconductor based solution of a 24 V battery master switch for trucks as required by the ADR regulation (European Agreement Concerning the International Carriage of Dangerous Goods by Road).

Note: This demonstrator does not cover all aspects of an ADR switch like control and diagnostics. Its focus lies solely on the switching element and the demonstration of the current carrying and short circuit handling capabilities.

The demonstrator consists of eight low ohmic MOSFETs connected in parallel and mounted on a structured copper IMS (insulated metal substrate) board together with a gate driver circuit to switch those MOSFETs on and off. In order to protect the MOSFETs against excessive overvoltage there are four transient voltage suppressor diodes implemented at the bottom side of the board.

Table 1 Main Components

Component	Type	Comment
MOSFETs (8x)	IPLU300N04S4-R8	300 A, 40 V, 0.53 mOhm typ.
TVS Diodes (4x)	SMDJ33A	33 V
Gate Driver	AUIR3242S	Normally on (default)
	AUIR3241S	Normally off (optional)

Thanks to the low ohmic MOSFETs the on state resistance of the whole switch is less than 160 $\mu\Omega$ from terminal to terminal. The eight parallel MOSFETs account for typically 67 $\mu\Omega$ at room temperature. At 120°C board temperature and 500 A current this value will increase to roughly 100 $\mu\Omega$.

Please note that the 24 V ADR Switch Demonstrator is a unidirectional switch. This means that it will interrupt current flowing from the battery to the load but not current flowing into the battery. The reason for this is the intrinsic body diode of the power MOSFETs as shown in Figure 1. Therefore charging through the MOSFETs should be avoided or at least limited to currents below 20 A when the switch is deactivated (off).

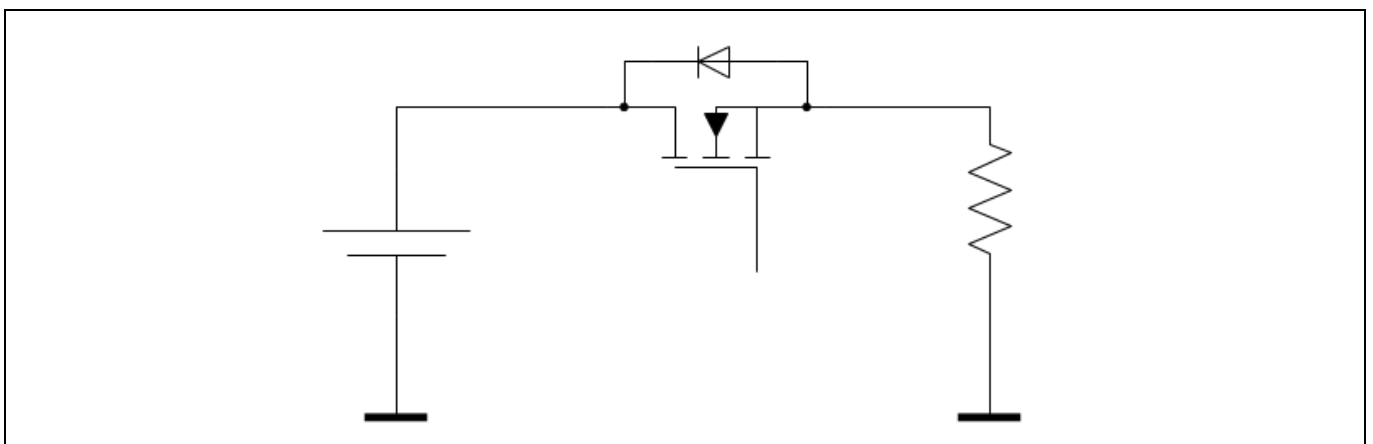

Figure 1 Unidirectional Switch due to MOSFET Body Diode



Figure 2 24 V ADR Switch Demonstrator Top View

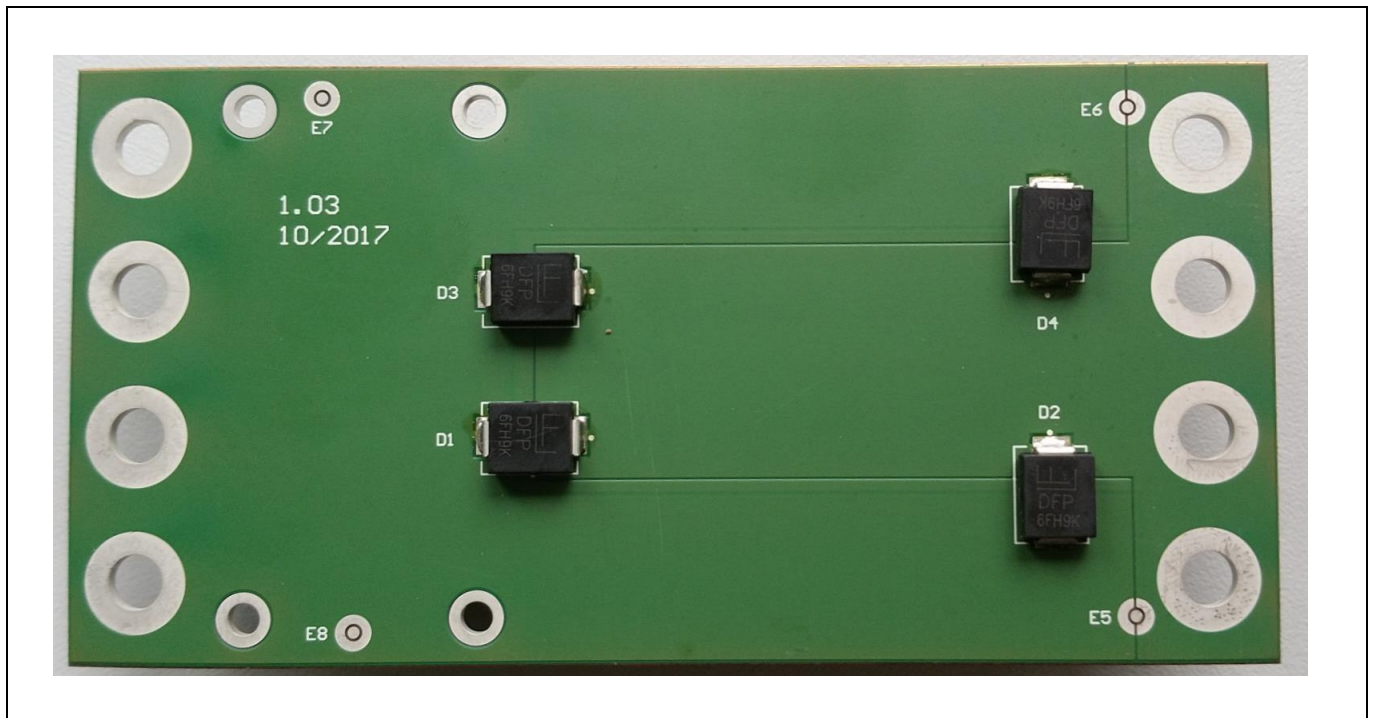

Figure 3 24 V ADR Switch Demonstrator Bottom View

2 Connecting the Switch

2.1 Overview

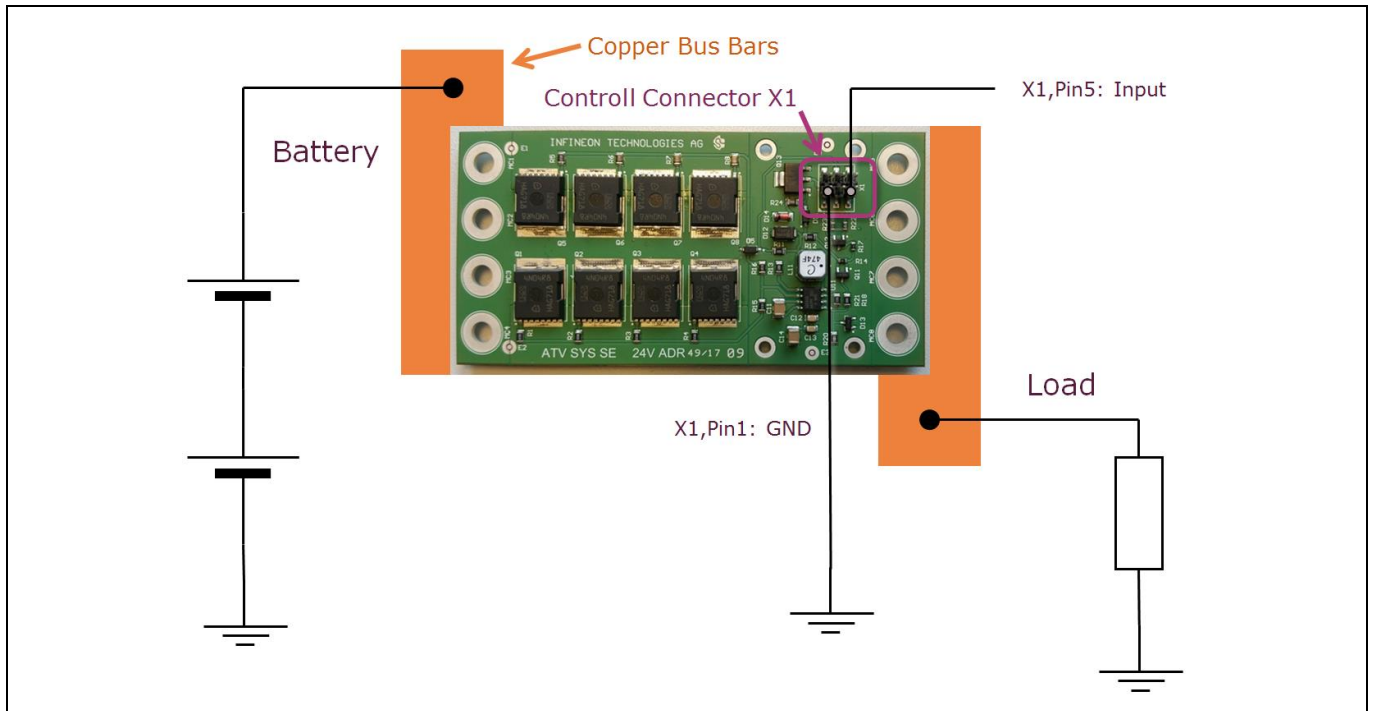

Figure 4 Basic Connection Diagram

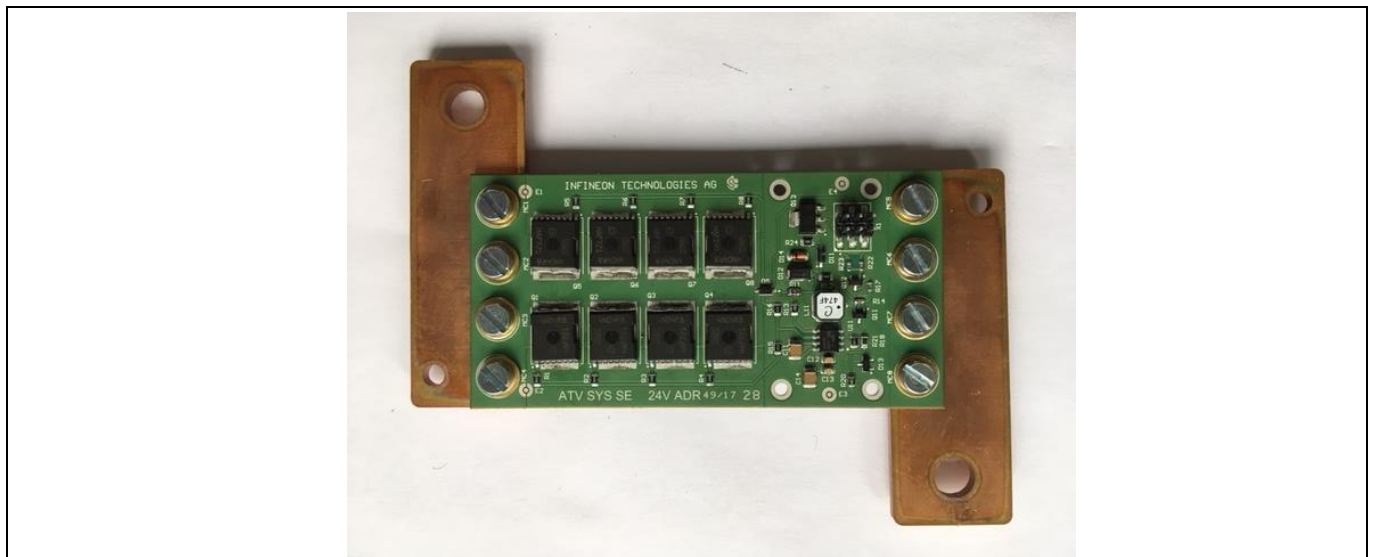

Figure 5 Connecting the Bus Bars with M4 Screws

The switch shall be connected between battery and load as pictured in Figure 4. It is recommended to use copper bus bars to provide a low ohmic current path. To ensure proper contact to the PCB please use copper washers between the PCB and the bus bar (Figure 6).

Mechanical dimensions of the board and the mounting holes can be found in chapter 6 Mechanical Dimensions

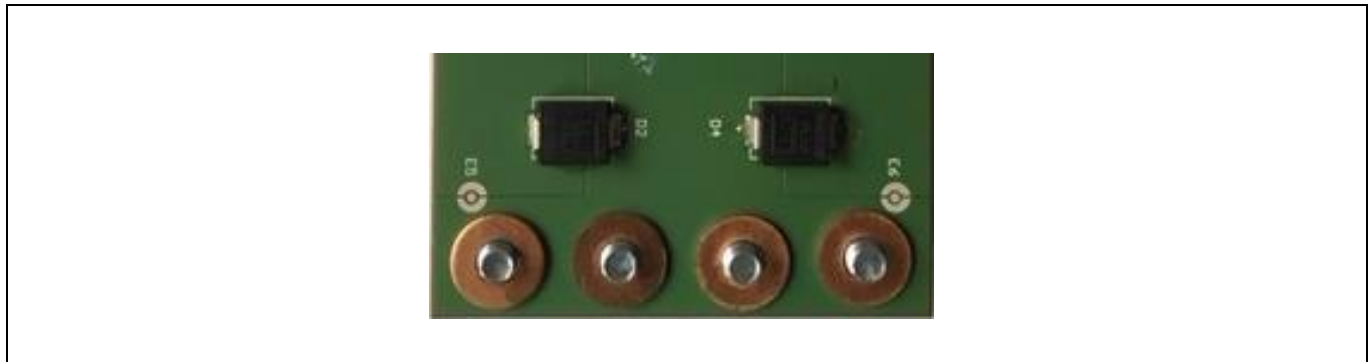

Figure 6 Copper washers between PCB and bus bar

2.2 Control

2.2.1 Pin Assignment

The switch can be controlled by a logic level signal on pin 5 (Input) of the header connector X1.

This connector is a standard 6-pin dual row 2.54 mm header (Samtec TSM-103-01-T-DV).

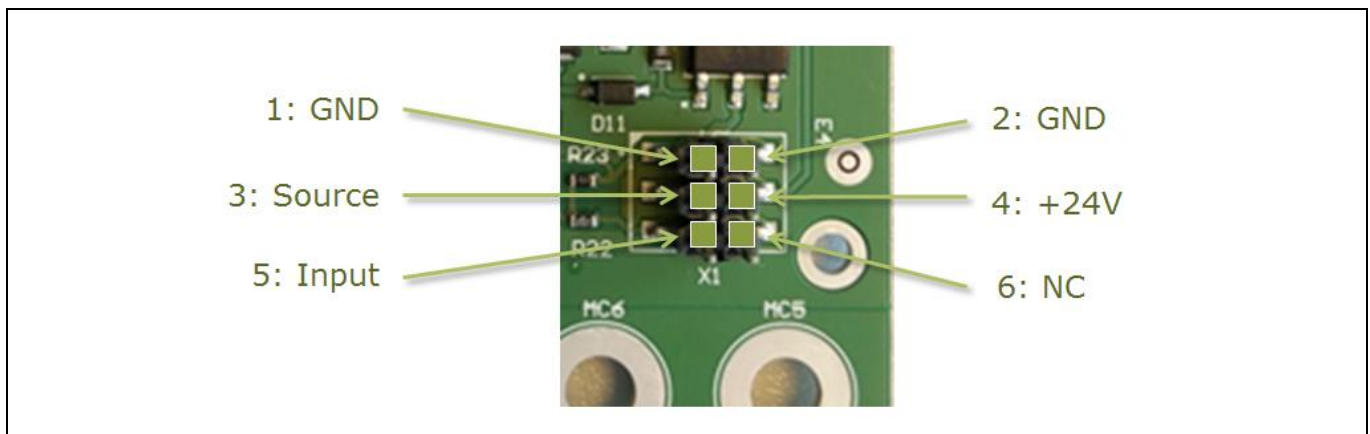

Figure 7 Control Connector X1 Pin Assignment

Table 2 X1 Pin Description

Pin	Name	Function
1	GND	Ground
2	GND	Ground
3	Source	Voltage at the output of the switch
4	+24 V	Voltage at the battery terminal of the switch, protected via diode against reverse polarity. Can be used to power own circuitry ³
5	Input	Control signal for switch
6	NC	Not connected

2.2.2 Input Voltage Range

The input will accept a very wide input voltage range. Therefore it is possible to drive the switch with 5 V logic as well as directly from the 24 V battery. The switching threshold is at approximately 0.8 V.

With increasing input voltage the input current will increase. It is mainly determined by the base resistor of the npn transistor at the input stage (see Figure 8).

Please note that the input should be properly biased by an external pull-down resistor. If the input is left floating it may react on disturbances like EMC or simply on touching it.

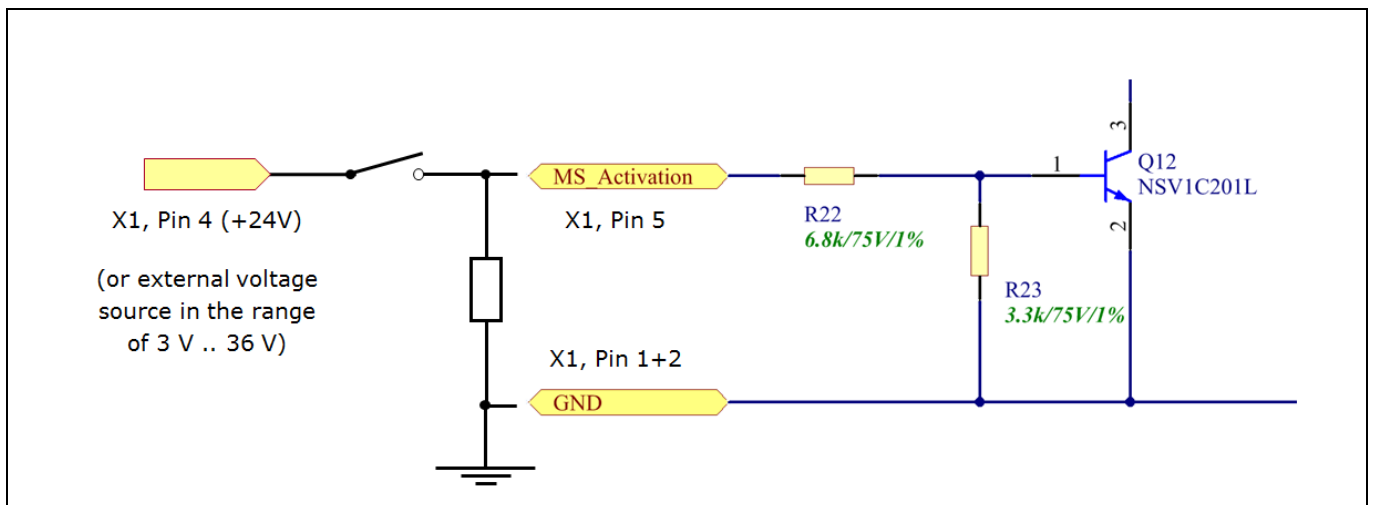

Figure 8 Input Stage

Depending on the driver IC used the switching logic differs. The AUIR3241S is a “normally off” driver, i.e. the switch is open when the input signal is low and closed when the input signal is high.

For the AUIR3242S the input logic is reversed. That means the switch will be conducting as long as the input signal is low and be opened when a high signal is applied. The advantage of the “normally on” driver AUIR3242S is the low quiescent current in “on” condition.

Logic Table

Input Signal	Switch Status for AUIR3242 (default)	Switch Status for AUIR3241
Low	Closed	Open
High	Open	Closed

2.2.3 Control with bistable relay adaptor

In order to emulate the behavior of a latching (bistable) power relay the ADR switch can be controlled using an adaptor board with a small bistable relay to drive the input. The adapter board is placed onto the connector X1 as shown in Figure 9.

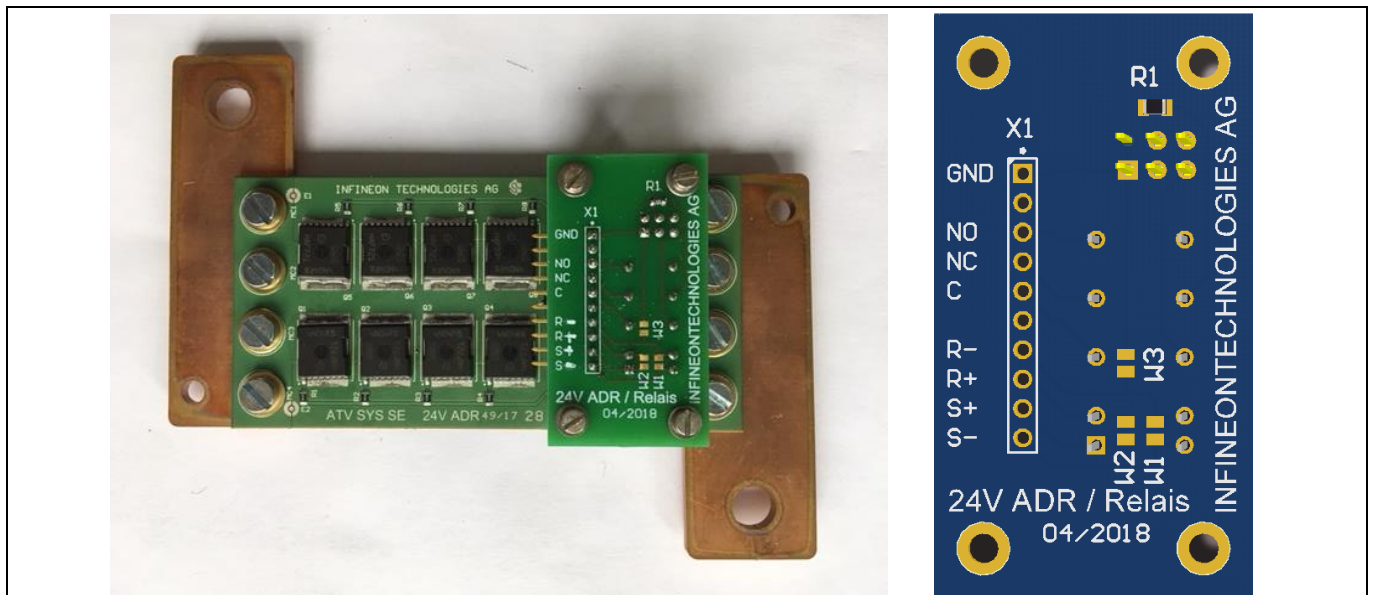

Figure 9 Mounting of bi-stable relay adaptor board

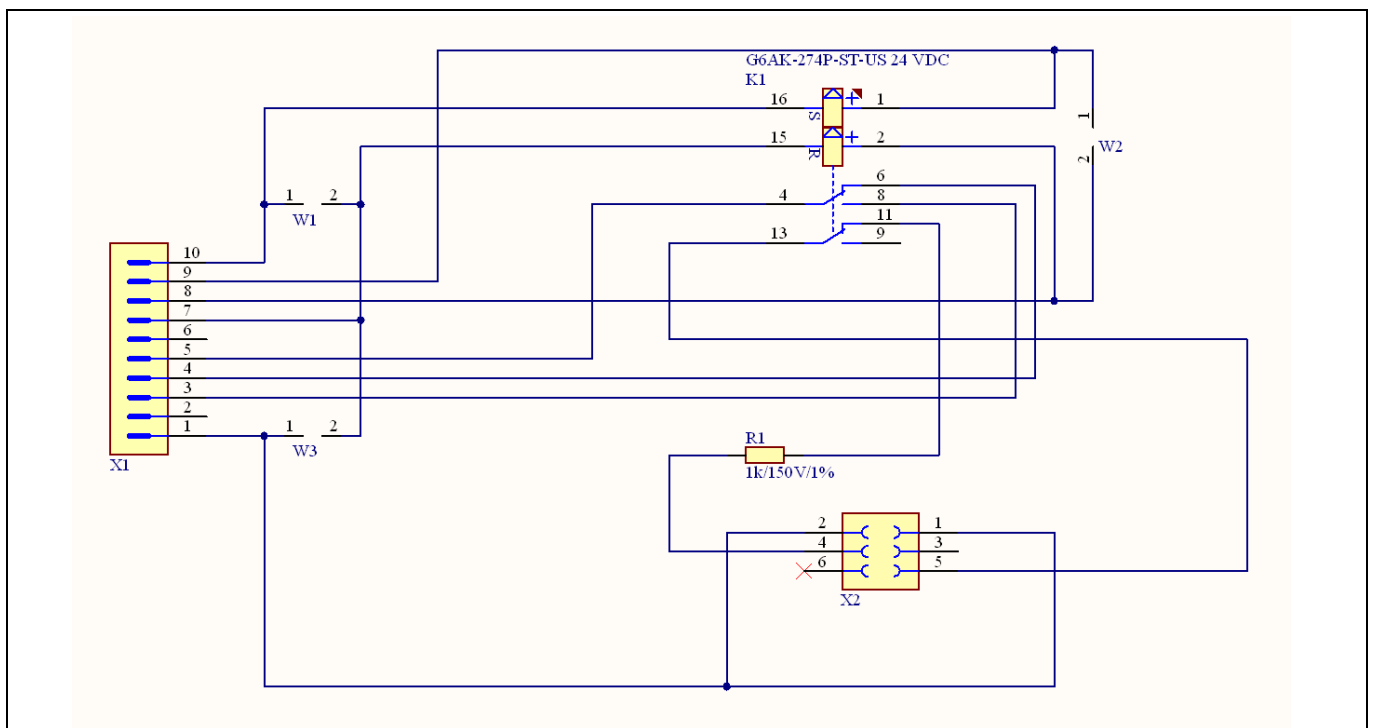

Figure 10 Schematics of adaptor board

Operating Range

3 Operating Range

3.1 Voltage Range

Figure 11 shows the different operating ranges of the ADR switch. The nominal operating voltage range is from 16 V to 36V.

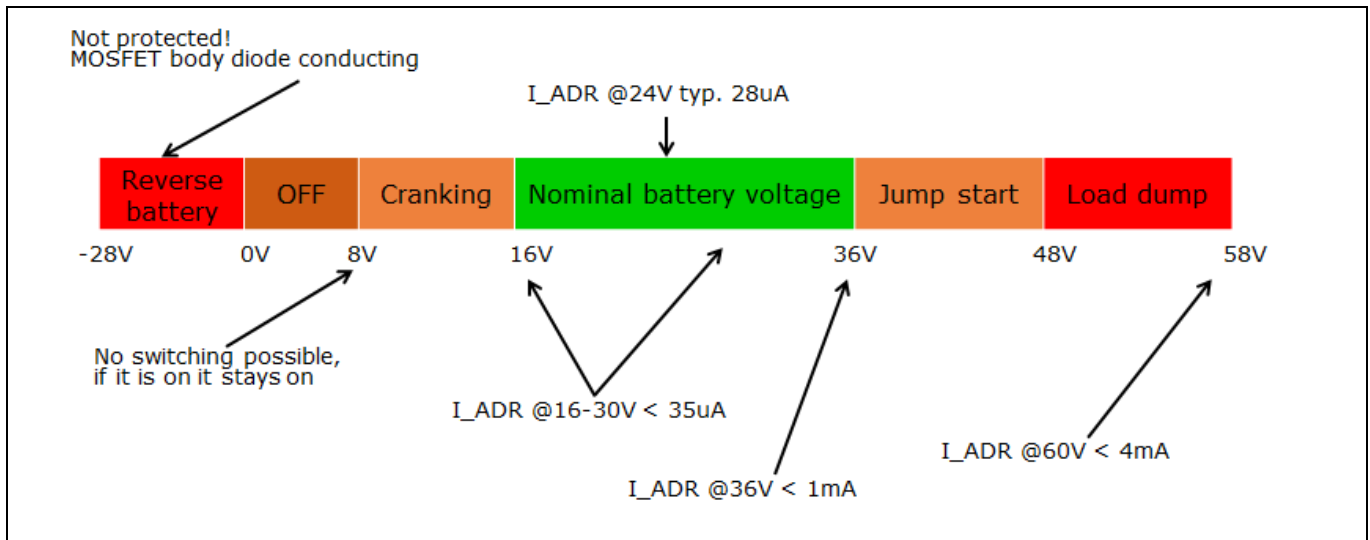

Figure 11 Operating Voltage Range

3.2 Current Rating

The switch is designed to handle peak currents up to 1800 A. However, due to the on-state resistance of the switch (160 $\mu\Omega$ typ. at 120°C) high currents will lead to significant power dissipation and a temperature increase in the MOSFETs. These can handle a maximum junction temperature of 175 °C. Therefore the maximum allowable duration for high currents is limited depending on the cooling conditions. The values in Table 3 are estimated for the board exposed to a small air flow of approximately 50 cm / min. and a start temperature of 25 °C.

Table 3 Current Carrying Capability Estimation

Current	Power Dissipation	Duration
300 A	~ 15 W	Continuous
500 A	~ 40 W	~ 10 min.
700 A	~ 80 W	~ 5 min.
1500 A	~ 360 W	~ 15 s
1800 A	~ 520 W	~ 10 s

4 Thermal Behavior

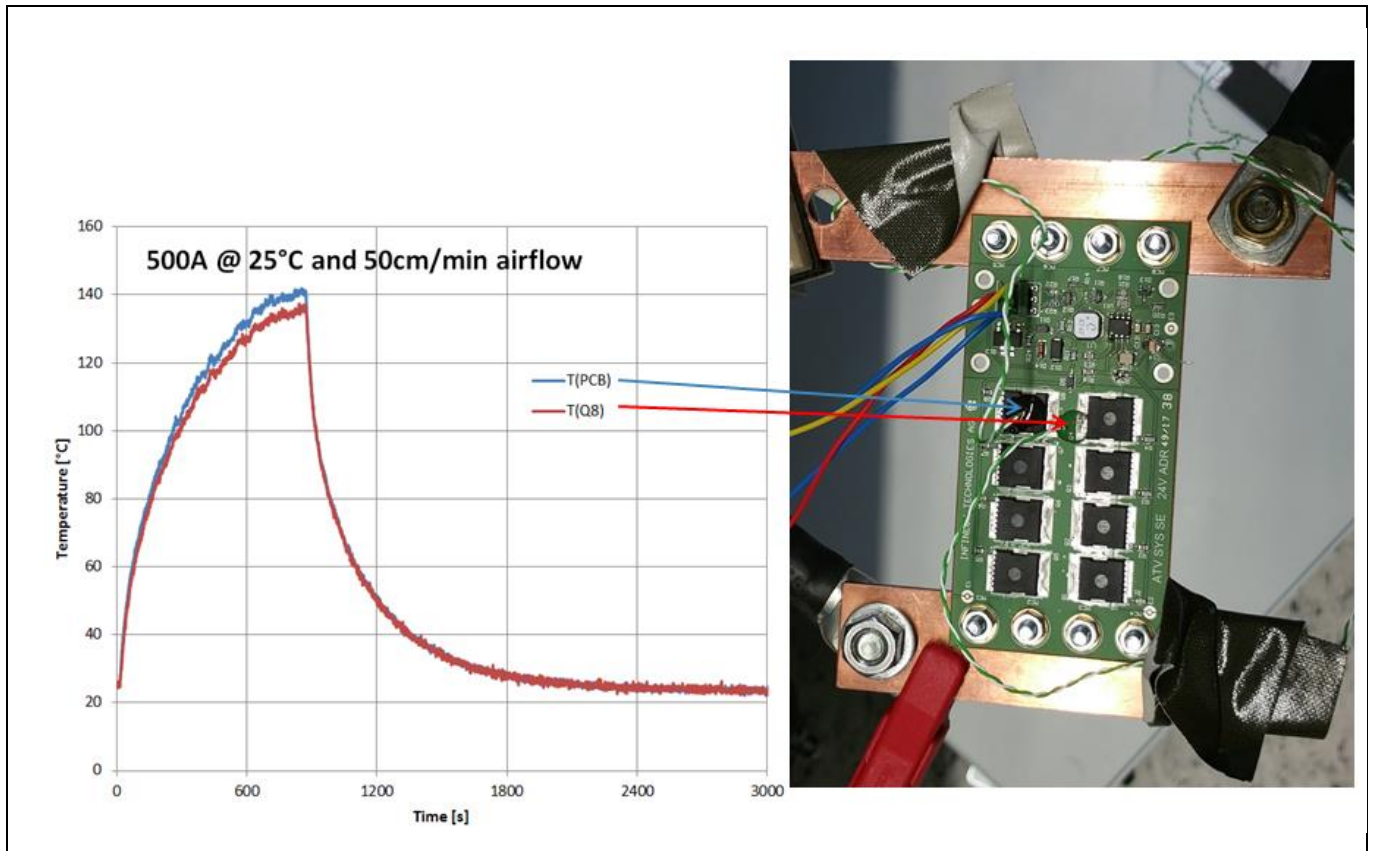

Figure 12 Temperature increase at high currents

Even if the on state resistance of the MOSFETs is very small, high currents will lead to power dissipation and therefore to a temperature increase. The maximum permissible junction temperature of the MOSFETs is 175 °C. Depending on the cooling conditions there is a limit on how long the switch can withstand the current. Figure 12 shows the temperature curve for a current of 500 A at room temperature and very light airflow around the board.

5 Switching Behaviour

In contrast to relays MOSFETs are switching much faster and cleaner. There is no bouncing of contacts and no arcing. Switching just takes microseconds instead of several milliseconds. The following oscilloscope pictures show the switching behavior of the 24 V ADR Switch Demonstrator with the “normally on” AUIR3242S driver. Please note that the magenta curve shows the drain source voltage across the MOSFETs, so a small voltage means the switch is on (conducting) and a high voltage means the switch is off (blocking). The delay between the input signal and the output is caused by the input circuitry.

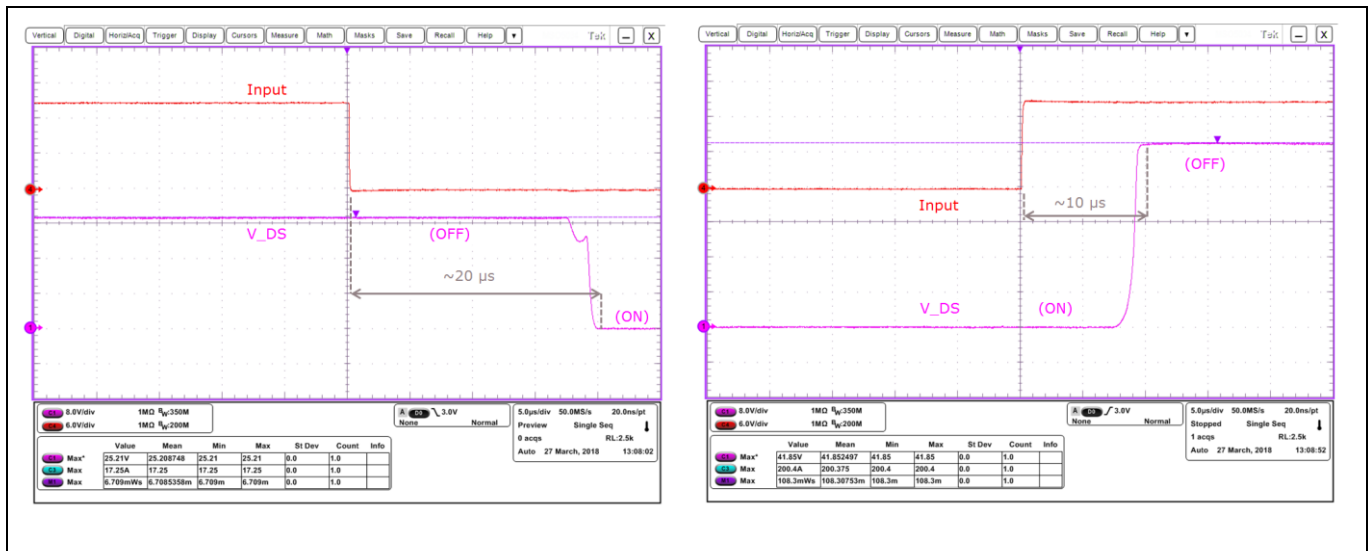

Figure 13 Switch Timing – On and Off

In the oscilloscope plots it can be seen that after switching off V_DS reaches 40 V. The reason for this is the load inductance. When the current flow is interrupted it induces a voltage that pulls the output below ground potential. As a result V_DS rises. When V_DS reaches the threshold of the transient voltage suppressor (TVS) diodes these start to conduct and to dissipate a part of the energy stored in the inductance. Another part of the energy will be taken over by the MOSFETs due to the avalanche effect, which sets in at a V_DS of about 40 V.

Note: The amount of switching energy that can be dissipated by the TVS diodes and the MOSFETs is limited. In our lab the 24 V ADR Switch Demonstrator has been tested successfully with cable inductances of up to 12 µH and currents up to 1600 A. The switch survived energies up to 20 Joule. However, this can just be seen as an indicator but not as a guarantee of which performance to expect. Since the load inductance is dependent on the specific system setup like cable length, -diameter, -routing etc. the suitability of the switch has to be verified for each setup separately.

6 Mechanical Dimensions

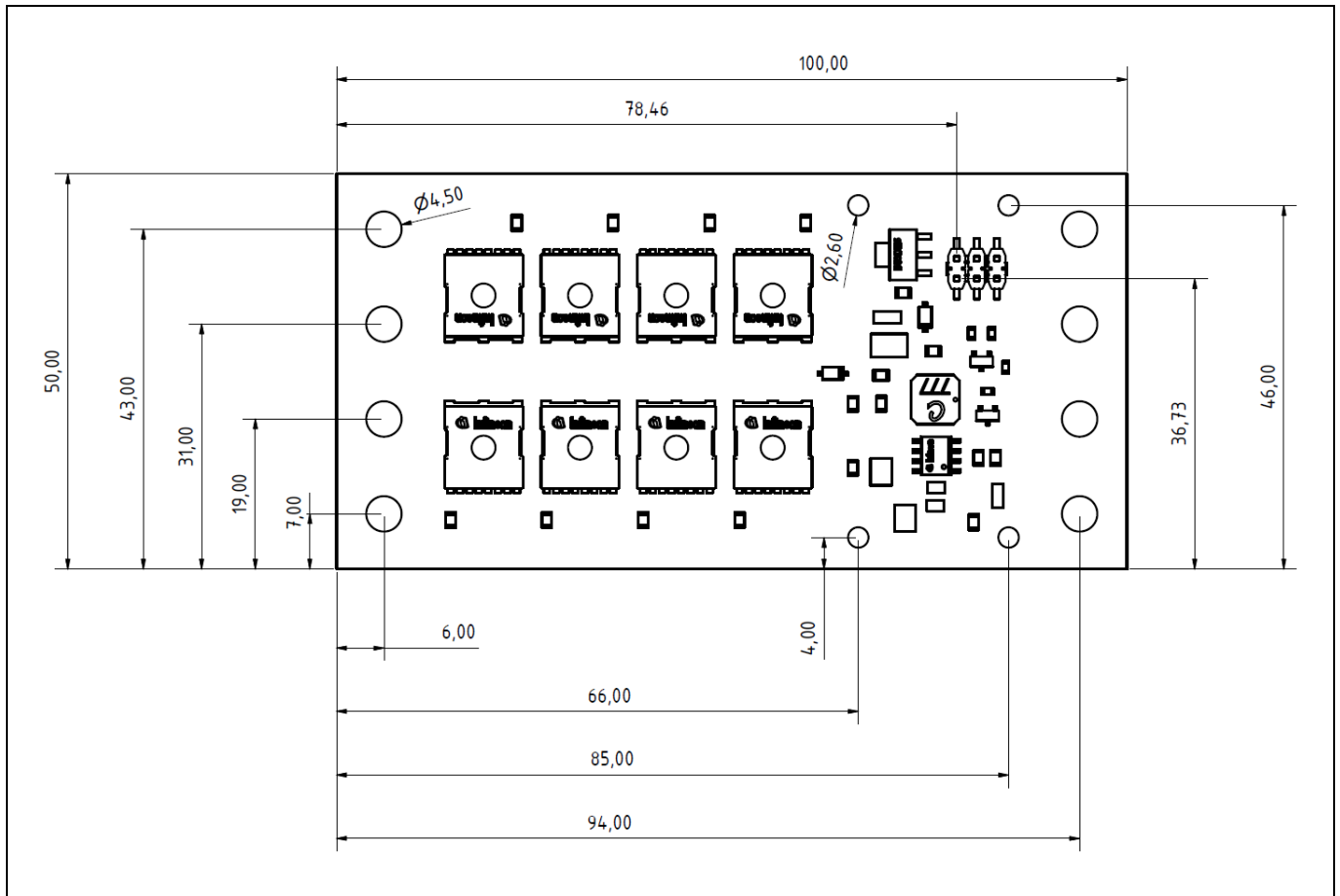

Figure 14 Board Dimensions [mm]

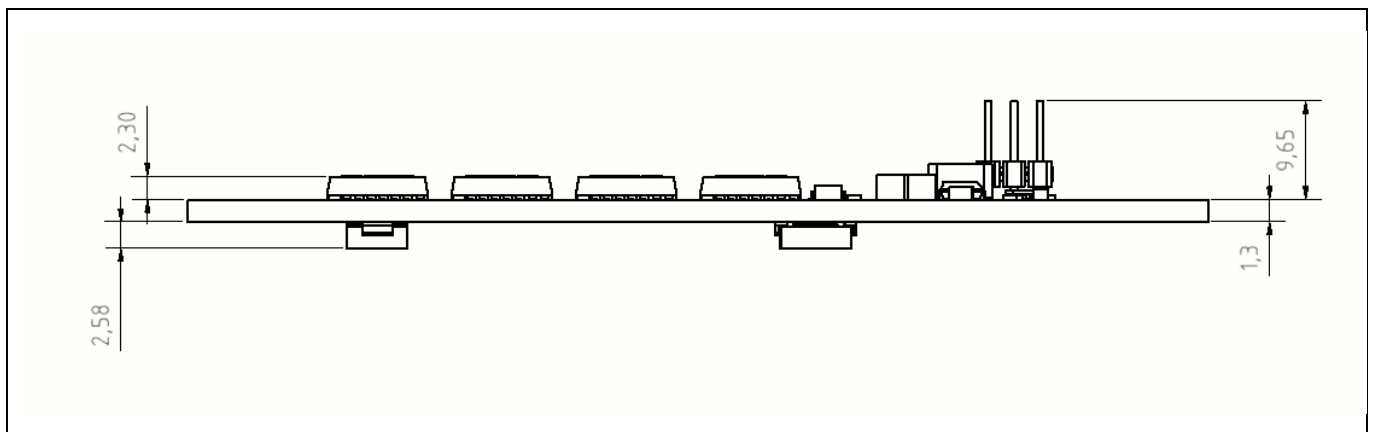

Figure 15 Side View

7 Schematics

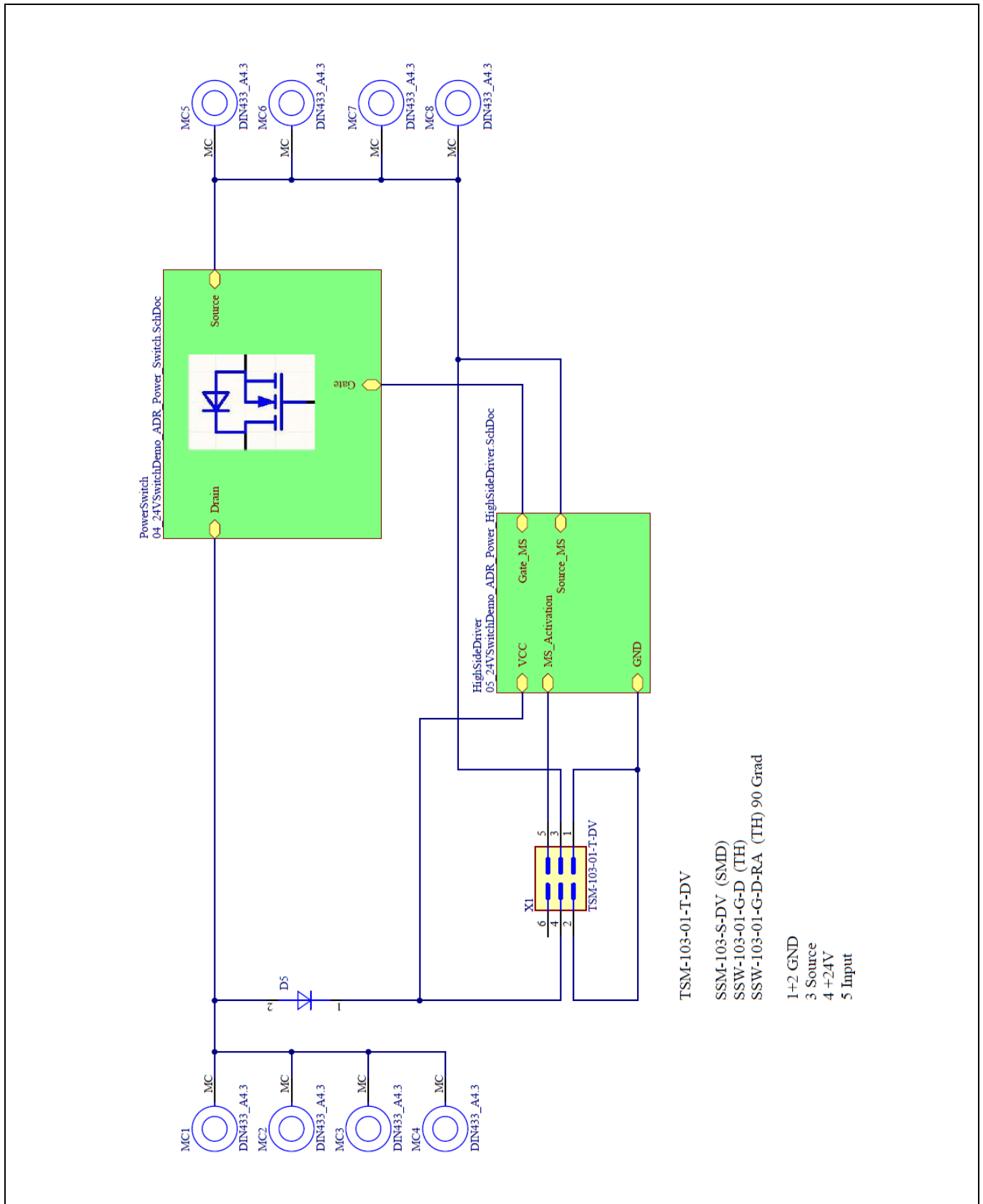

Figure 16 Top Level Schematics

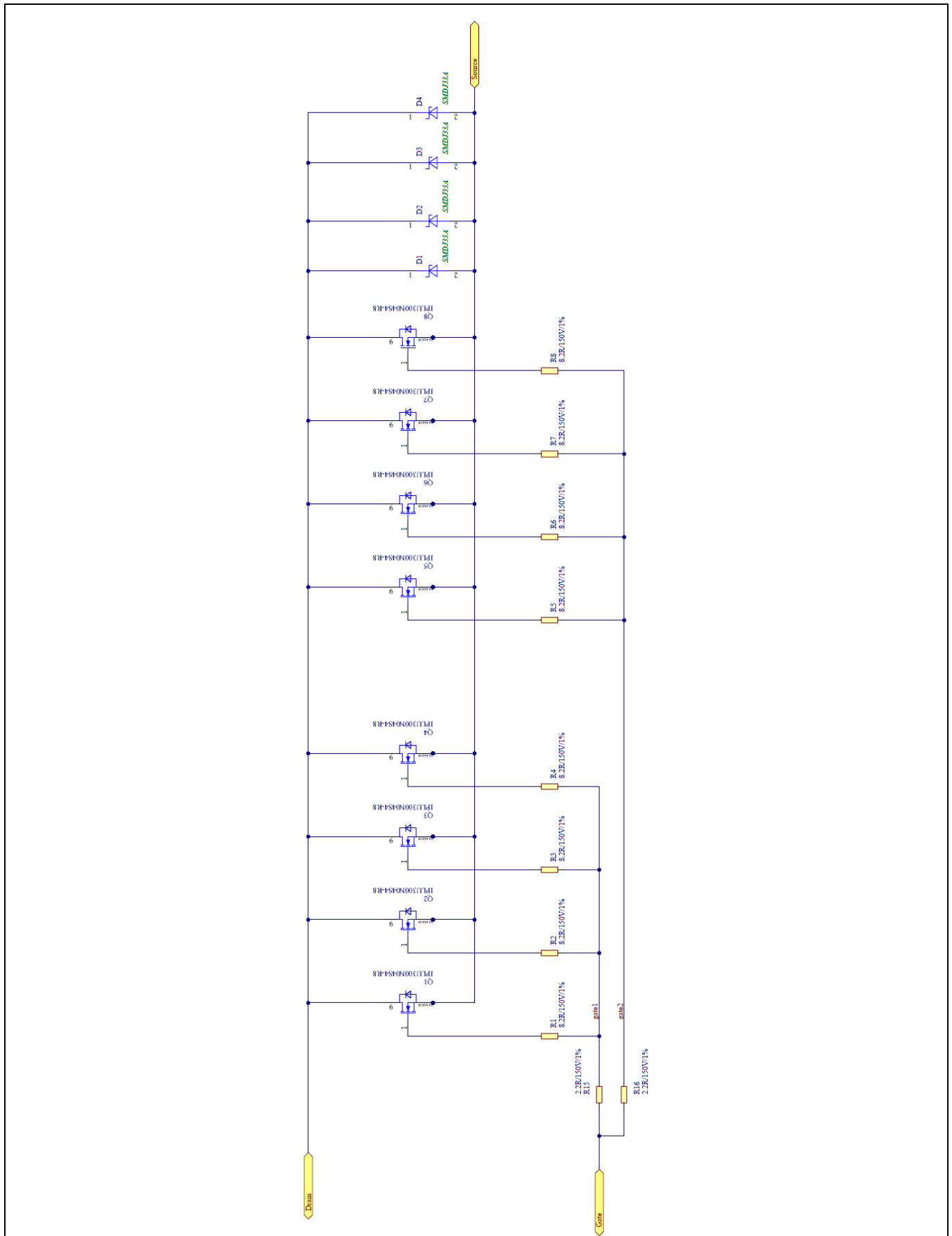

Figure 18 Power Stage

8 PCB Description

8.1 PCB Technology

The Printed Circuit Board used for the shown 24 V ADR Switch Demonstrator is a product idea of [Schweizer Electronic AG](#). The deployment of the [Inlay Board 2.0](#) technology assures highest current carrying capability in conjunction with lowest thermal resistance. A superior thermal connection between the MOSFETs and the integrated power rail of the PCB allows to conduct a permanent current of up to 500 A and a short-circuit current of up to 1800 A.

Table 4 Feature Set of Metal Core Board (Non-Isolated Version)

Feature	Value
Size	100.0 mm x 50.0 mm
Thickness	1,3 mm
Electrical resistance	60 $\mu\Omega$
Thermal resistance (non-isolated version)	0.1 K/W
Thermal resistance (isolated version)	~ 0.2 K/W
No. of copper-filled laser vias per MOSFET	300

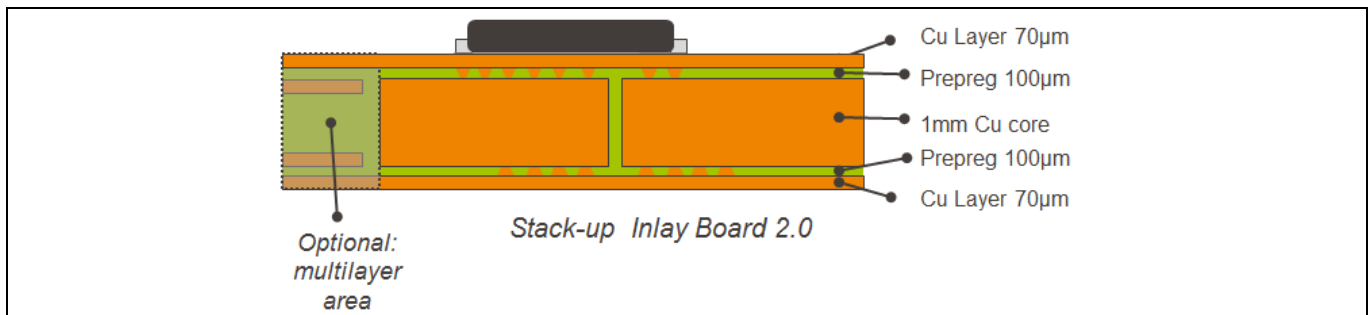

Figure 19 PCB Stackup

The core of the PCB is a copper plate of 1.0 mm thickness which represents the power rail for the ADR switch. This copper plate is structured by an isolation gap of 500 μm width. By means of a lamination process the isolation gap is filled with the resin from Prepreg material. This represents a safe isolation space between battery and load potential. The outer layers are consisting of 35 μm copper foils, after plating 70 μm . To ensure both a low-ohmic electrical connection from the MOSFETs to the current rail and a good heat flow to a potentially used heatsink, the PCB is provided with hundreds of [copper-filled microvias](#) in the soldering area of the MOSFET and on the back-side of the PCB. The high filling factor with dimple depths lower than 25 μm allows the designer to have the MOSFETs soldered on top of the via field without facing the risk of solder voids. During assembly it has to be made sure that solder profiles will be used which are appropriate for power PCBs with a large thermal mass. The MOSFETs are placed on the PCB so that the MOSFETs, once they are turned on, connect the two isolated parts of the PCB.



Figure 20 Cross Section

For higher logic content requirements compared to the presented ADR switch demonstrator the Inlay Board 2.0 technology can optionally accommodate an area with four or more electrical layers next to the power rails.

8.2 PCB Layout

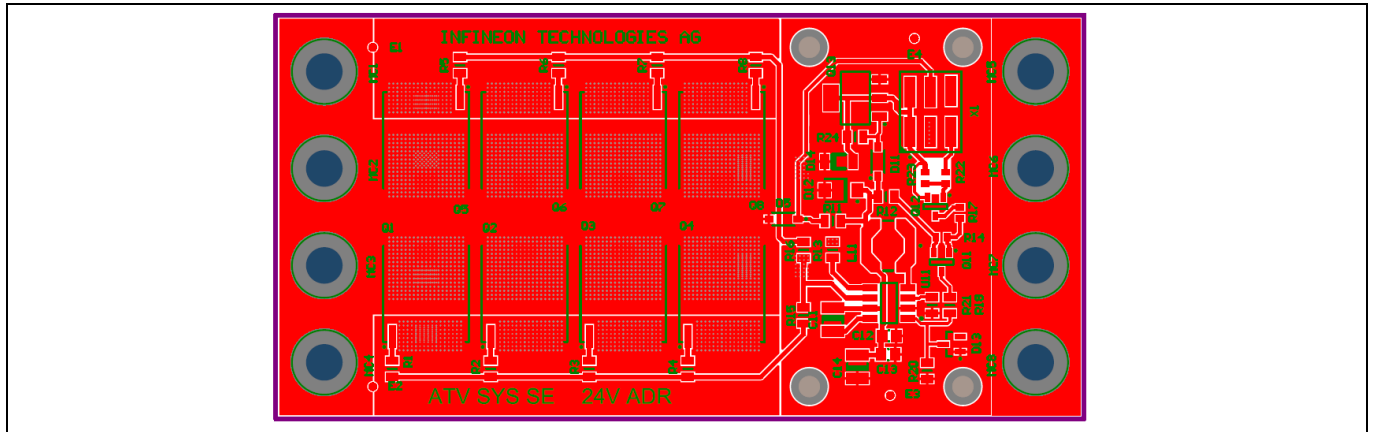

Figure 21 Top Layer

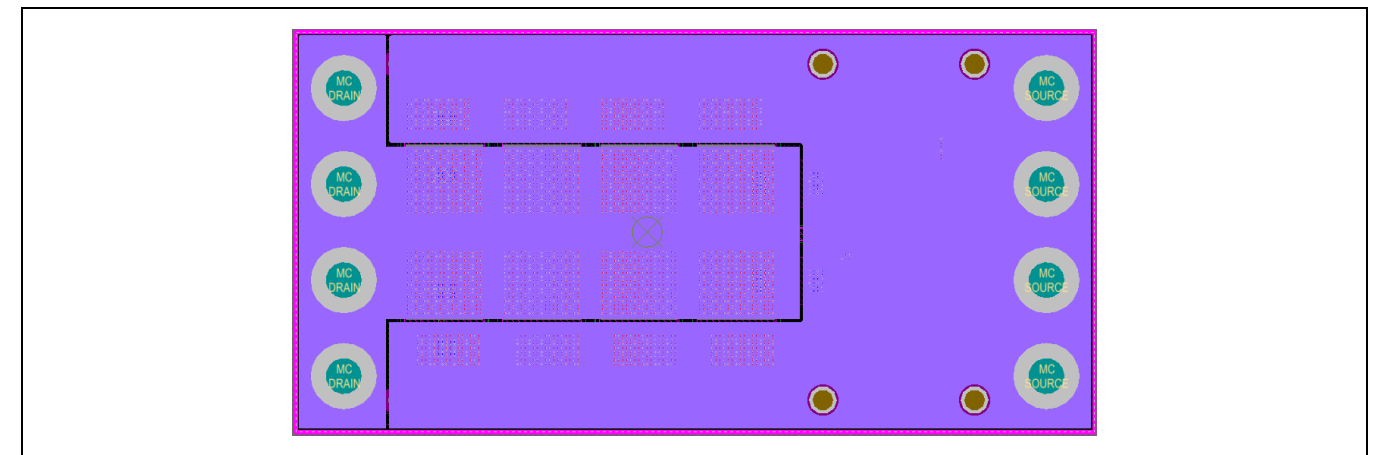

Figure 22 Middle Layer (1mm Cu)

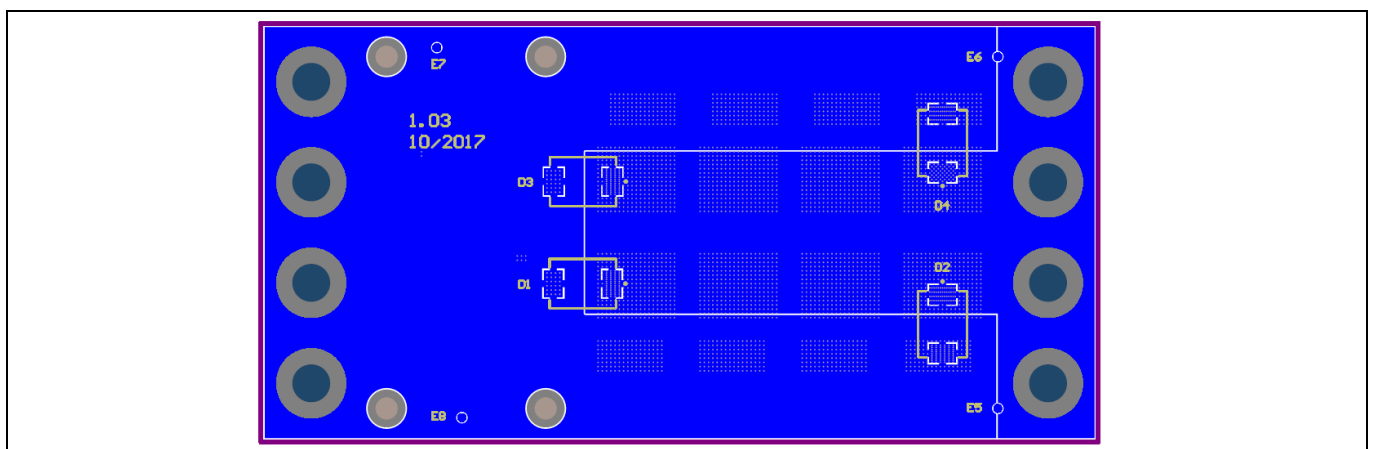

Figure 23 Bottom Layer

9 Bill Of Materials

Table 5 BOM

Designator	Value	Description
D1, D2, D3, D4	SMDJ33A	Transient Voltage Suppression Diode, Uni-directional, 33V
D11	MMSZ5256BT1G	Zener Voltage Regulator, 500mW, 30V
D12	SZ1SMA5938BT3	Zener Voltage Regulator, 36V
D13	BZX84C5V1LTG	Zener Voltage Regulator, 5.1V
D14	LL4148	Small Signal Diode, 100V
D5	1N4148W-13-F	Surface Mount Fast Switching Diode
R13	1R	1R/150V/1%
C11, C14	1u/100V	Cap-1210-1u/100V/0.1/X7R
R15, R16	2.2R	2.2R/150V/1%
R14, R23	3.3k	3.3k/75V/1%
R11	5.6R	5.6R/150V/1%
R20	6.8k	6.8k/150V/1%
R22	6.8k	6.8k/75V/1%
R1 .. R8	8.2R	8.2R/150V/1%
R24	10k	10k/150V/1%
R18	12k	12k/150V/1%
R21	12R	12R/150V/1%
R17	22k	22k/75V/1%
C12	100n	Cap-0805-100n/100V/0.1/X7R
R12	100R	100R/150V/1%
C13	220n	Cap-0805-220n/50V/0.1/X7R
L11	470uH	Shielded Power Inductor
U11	AUIR3242S	Low Quiescent Current Back to Back MOSFET Driver
Q13	FZT753	100V PNP High Performance Transistor
Q1 .. Q8	IPLU300N04S4-R8	OptiMOS T2 N-Channel Enhancement Power-Transistor, 40 V
Q11	NSV1C200L	100V, 2.0 A, Low VCEsat PNP Transistor
Q12	NSV1C201L	100V, 3.0 A, Low VCEsat NPN Transistor
X1	TSM-103-01-T-DV	SMT .025" SQ Post Header, 2.54mm, 6 pin, vertical, double row

Revision History

Major changes since the last revision

Page or Reference	Description of change
Figure 19	New picture

Trademarks of Infineon Technologies AG

μ HVIC™, μ IPM™, μ PFC™, AU-ConvertIR™, AURIX™, C166™, CanPAK™, CIPOS™, CIPURSE™, CoolDP™, CoolGaN™, COOLiR™, CoolMOS™, CoolSET™, CoolSiC™, DAVE™, DI-POL™, DirectFET™, DrBlade™, EasyPIM™, EconoBRIDGE™, EconoDUAL™, EconoPACK™, EconoPIM™, EiceDRIVER™, eupec™, FCOS™, GaNpowIR™, HEXFET™, HITFET™, HybridPACK™, iMOTION™, IRAM™, ISOFACE™, IsoPACK™, LEDrivIR™, LITIX™, MIPAQ™, ModSTACK™, my-d™, NovalithIC™, OPTIGA™, OptiMOS™, ORIGA™, PowIRaudio™, PowIRStage™, PrimePACK™, PrimeSTACK™, PROFET™, PRO-SIL™, RASIC™, REAL3™, SmartLEWIS™, SOLID FLASH™, SPOC™, StrongIRFET™, SupIRBuck™, TEMPFET™, TRENCHSTOP™, TriCore™, UHVIC™, XHP™, XMC™

Trademarks updated November 2015

Other Trademarks

All referenced product or service names and trademarks are the property of their respective owners.

Edition 2018-07-23

Published by

Infineon Technologies AG

81726 Munich, Germany

© 2018 Infineon Technologies AG.

All Rights Reserved.

IMPORTANT NOTICE

The information contained in this application note is given as a hint for the implementation of the product only and shall in no event be regarded as a description or warranty of a certain functionality, condition or quality of the product. Before implementation of the product, the recipient of this application note must verify any function and other technical information given herein in the real application. Infineon Technologies hereby disclaims any and all warranties and liabilities of any kind (including without limitation warranties of non-infringement of intellectual property rights of any third party) with respect to any and all information given in this application note.

The data contained in this document is exclusively intended for technically trained staff. It is the responsibility of customer's technical departments to evaluate the suitability of the product for the intended application and the completeness of the product information given in this document with respect to such application.

For further information on the product, technology delivery terms and conditions and prices please contact your nearest Infineon Technologies office (www.infineon.com).

WARNINGS

Due to technical requirements products may contain dangerous substances. For information on the types in question please contact your nearest Infineon Technologies office.

Except as otherwise explicitly approved by Infineon Technologies in a written document signed by authorized representatives of Infineon Technologies, Infineon Technologies' products may not be used in any applications where a failure of the product or any consequences of the use thereof can reasonably be expected to result in personal injury.