

FPS SERIES 1000W In 1U
Front End Power Supplies

INSTRUCTION MANUAL

This Manual Cover Models:

FPS1000-12

FPS1000-24

FPS1000-32

FPS1000-48

FPS-S1U 19" Rack Single Output

FPS-T1U 19" Rack Triple Output

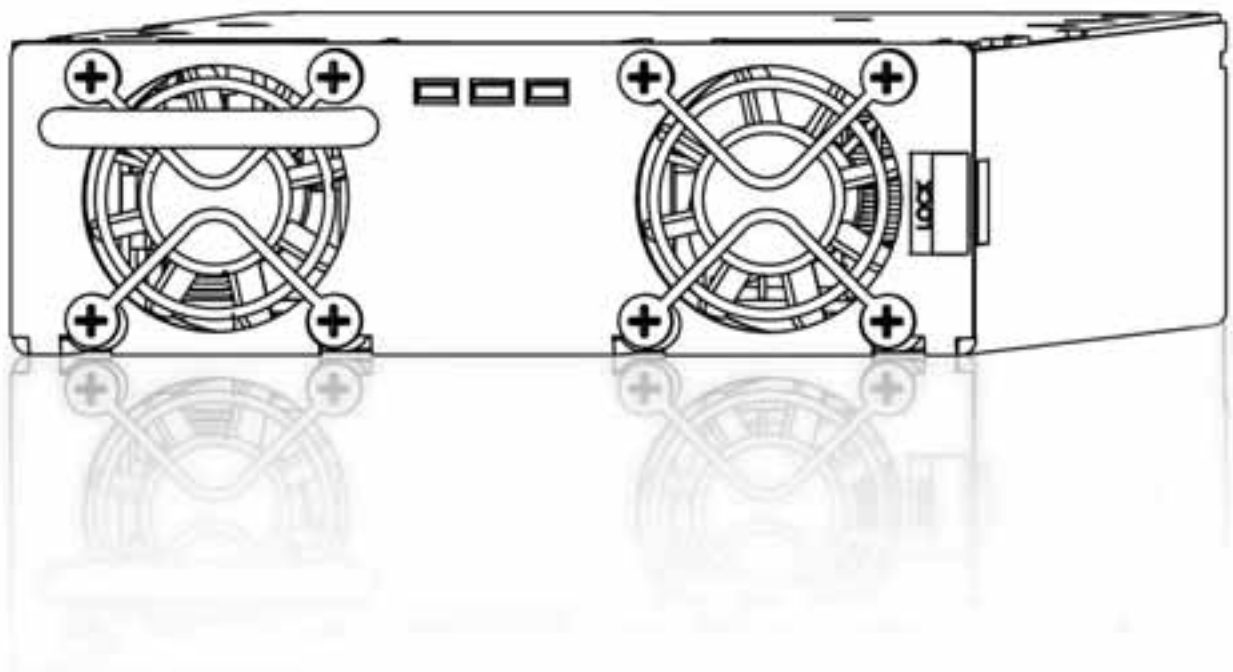

FPS1000 SERIES INSTRUCTION MANUAL

TABLE OF CONTENTS

Warranty	Pg. 1
FPS1000, FPS-S1U and FPS-T1U rack Safety instructions	Pg. 2
FPS1000 Power Supply	
Chapter 1: FPS1000 Series Specifications	Pg. 4
Chapter 2: FPS1000 Series Outline drawings	Pg. 5
Chapter 3: FPS1000 Series Installation instructions	Pg. 7
Chapter 4: Functions and features	Pg. 11
Chapter 5: Basic connections for operation	Pg. 14
Chapter 6: Parallel and Series operation	Pg. 16
Chapter 7: I ² C BUS Interface option	Pg. 19
Chapter 8: FPS1000 Maintenance	Pg. 23
FPS-S1U rack	
Chapter 9: FPS-S1U rack Specifications	Pg. 25
Chapter 10: FPS-S1U rack Installation instructions	Pg. 26
Chapter 11: FPS-S1U and FPS-S1U/P Outline drawings	Pg. 30
Chapter 12: Basic connections for operation	Pg. 32
Chapter 13: Parallel and Series operation	Pg. 34
Chapter 14: FPS-S1U I ² C BUS Interface option	Pg. 37
Chapter 15: FPS-S1U rack Maintenance	Pg. 38
FPS-T1U rack	
Chapter 16: FPS-T1U rack Specifications	Pg. 40
Chapter 17: FPS-T1U rack Installation instructions	Pg. 41
Chapter 18: FPS-T1U and FPS-T1U/P Outline drawings	Pg. 45
Chapter 19: Basic connections for operation	Pg. 47
Chapter 20: Parallel and Series operation	Pg. 49
Chapter 21: FPS-T1U I ² C BUS Interface option	Pg. 51
Chapter 22: FPS-T1U rack Maintenance	Pg. 52

WARRANTY

This Densei-Lambda product is warranted against defects in materials and workmanship for a period of two years from date of shipment.

During the warranty period, Densei-Lambda will, at its option, either repair or replace products which prove to be defective.

LIMITATION OF WARRANTY

The warranty shall not apply to defects resulting from improper or inadequate usage or maintenance by the buyer, buyer supplied products or interfacing. The warranty shall not apply to defects resulting from unauthorized modifications or from operation exceeding the environmental specifications of the product or if the Warranty seal has been removed or altered by anyone other than Densei-Lambda authorized personnel.

Densei-Lambda does not warrant the buyers circuitry or malfunctions of Densei-Lambda products resulting from the buyer's circuitry. Furthermore, Densei-Lambda does not warrant any damage occurring as a result of the buyer's circuitry or the buyer's-supplied products.

No other warranty is expressed or implied.

WARRANTY SERVICE

This product must be returned to an authorized Densei-Lambda service facility for repairs or other warranty service. For products returned to Densei-Lambda for warranty service, the buyer shall prepay shipping charges to Densei-Lambda and Densei-Lambda shall pay the shipping charges to return the product to the buyer.

DISCLAIMER

The information contained in this document is subject to change without notice.

Densei-Lambda shall not be liable for errors contained in this document or for incidental or consequential damages in connection with the furnishing, performance, or use of this material. No part of this document may be photo-copied, reproduced or translated to another language without prior written consent of Densei-Lambda.

FPS1000 POWER SUPPLY AND FPS-S1U RACK SAFETY INSTRUCTIONS

IMPORTANT SAFETY INSTRUCTIONS

Operating personnel must not remove the FPS1000, FPS-S1U and the FPS-T1U cover.

No internal adjustment or component replacement is allowed by non Densel-Lambda qualified service personnel. Never replace components with power cable connected. To avoid injuries, always disconnect power, discharge circuits and remove external voltage sources before touching components. These products are not authorized for use as critical components in nuclear control systems, life support systems or equipment for use in hazardous environments without the express written approval of the managing director of Densel-Lambda.

Restricted Access Area: The equipment should only be installed in a Restricted Access Area.

Access should be available to service personnel only.

WICHTIGE SICHERHEITSHINWEISE

Bedienungspersonal oder Anwender dürfen die Gehäuseabdeckung des FPS1000, FPS-S1U und des FPS-T1U nicht entfernen. Ersatzteiltausch - und Änderungen dürfen nur von autorisiertem Densel-Lambda SERVICE-Personen bzw. Organisationen durchgeführt werden. Vor Austausch von Bauteilen ist das Netzkabel bzw. die Versorgungsspannung zu trennen.

Energieversorgungsanschlüsse sind immer zu trennen, um Personenverletzungen durch gefährliche Energieinhalte und Spannungen auszuschließen.

Die Stromkreise sind zu entladen, externe Spannungsquellen sind zu entfernen bevor Bauteile bzw. Komponenten getauscht werden.

Der direkte Zugriff auf das Racksystem ist nur dem geschulten Service-Personal erlaubt.

SAFETY APPROVALS

UL60950-1, UL Recognized, C-UL for Canada. IEC/EN60950-1. CE marking, when applied to the FPS1000, FPS-S1U and the FPS-T1U products, indicates compliance with the Low Voltage Directive (73/23EEC) as modified by the CE Marking Directive (93/68EEC) in that it complies with EN60950-1.

SAFETY-CLASS OF INSULATION

The FPS1000, FPS-S1U and the FPS-T1U are designed for the following safety parameters: Material group IIIa, Pollution degree 2, Overvoltage category II, Class I (earthed), indoor use as part of an overall equipment such that the FPS product is accessible to service personnel only.

GROUNDING

These products are Safety Class I instruments. To minimize shock hazard, the instruments chassis must be connected to an electrical ground. The instruments must be connected to the AC power supply mains through a three conductor power cable, with the ground wire firmly connected to an electrical ground (safety ground) at the power outlet.

For instruments designed to be hard-wired to the supply mains, the protective earth terminal must be connected to the safety electrical ground before any other connection is made.

Any interruption of the protective ground conductor, or disconnection of the protective earth terminal will cause a potential shock hazard that might cause personal injury.

INPUT RATINGS

Do not use AC supply which exceeds the input voltage and frequency rating of these instruments. The input voltage and frequency rating is: 100-240V~, 50/60Hz. For safety reasons, the mains supply voltage fluctuations should not exceed +/- 10% of nominal voltage.

FPS-S1U RACK AC INPUT

CAUTION:

Risk of electrical shock and energy hazard. Disconnecting one power supply disconnects only one power supply module. To isolate the unit completely, disconnect all power supplies.

ACHTUNG:

Spannungsführende Teile - Gefahr durch elektrischen Schlag oder hohe Energieinhalte.

Alle Netzstecker der einzelnen Komponenten bzw. der Einschübe müssen getrennt werden, damit das System "spannungsfrei" ist.

ATTENTION:

Risque de choc et de danger e'lectriques. Le de'branchement d'une seule alimentation stabilise'e ne de'branche uniquement qu'un module "Alimentation Stabilise'e".
 Pour isoler completement le module en cause, il faut de'brancher toutes les alimentations stabilise'es.

SAFETY SYMBOLS



CAUTION Risk of Electrical Shock.



Instruction manual symbol. The instrument will be marked with this symbol when it is necessary for the user to refer to the instruction manual.



Indicates hazardous voltage.



Indicates ground terminal.



Protective Ground Conductor Terminal



Denotes hazard. An attention to a procedure is called. Not following the procedure correctly could result in personal injury. A WARNING sign should not be skipped and all indicated conditions must be fully understood and met.



Denotes hazard. An attention to a procedure is called. Not following the procedure correctly could result in damage to the equipment.

ENERGY HAZARD

The FPS1000, FPS-S1U and the FPS-T1U products are capable of providing hazardous energy. Manufacturers final equipment must provide protection to service personnel against inadvertent contact with these models output terminals. If set such that hazardous energy can occur then the output terminals or connections therefore must not be user accessible.

OVERCURRENT PROTECTION:

A readily accessible Listed branch circuit overcurrent protective device rated 20 A must be incorporated in the building wiring.

SERIAL OPERATION

The FPS-T1U product is capable of providing hazardous voltage output in case of the serial connection of two or more FPS1000 units in the rack. Manufacturers final equipment must provide protection to service personnel against inadvertent contact with these models output terminals. If set such that hazardous voltage can occur then the output terminals or connections therefore

FUSES

There are no user replaceable fuses in the FPS1000, FPS-S1U and the FPS-T1U products. Internal fuses are sized for fault protection and if a fuse was opened it would indicate that service is required. Fuse replacement should be made by qualified technical personnel.

FPS-S1U and FPS-T1U racks contains no fuses. FPS1000 fuses rating are described below.

F101: F20A H 250Vac

F102: 6.3A 400Vdc

SICHERHEITSHINWEISE

Vor Anschluss an die Netzversorgung ist die Aufstellanleitung zu beachten!

1. Absicherung: F101: F20A H 250VAC, F102: 6.3A 400VDC
2. Der maximale Ableitstrom der Gesamtanlage darf 3.5mA nicht ueberschreiten.
3. Die Gehaeuseabdeckung darf nur im stromlosen Zustand geoeffnet werden.

ACHTUNG:

Sicherungen duerfen nur durch geschulte Service Personen getauscht werden.

CHAPTER 1 FPS1000 SERIES SPECIFICATIONS

FPS1000 SERIES SPECIFICATIONS			FPS1000-12	FPS1000-24	FPS1000-32	FPS1000-48
1	Rated output voltage	V	12	24	32	48
2	Output voltage set point	V	12+/-1%	24+/-1%	32+/-1%	48+/-1%
3	Output voltage range	V	10.5~13.2	21.5~29	28.8~38.4	43~58
4	Maximum Output Current (Refer to Fig.1)	A	72	40	31	21
5	Maximum output power	W	864	960	992	1008
6	Input voltage / frequency range (*1)	---	85~265Vac continuous, 47~63Hz, Single phase			
7	Maximum input current (at 100/200Vac)	A	12.0/6.0			
8	Power Factor (Typ)	---	>0.98 at 115/230V and maximum output power			
9	Efficiency (Typ)	%	81/83%	84/86%	84/86%	85/88%
10	Inrush current (*3)	A	Less than 40A			
11	Hold-up time	mS	20mS typical at 100Vac input, rated output voltage and less than 80% of rated load.			
12	Maximum line regulation (*5)	---	0.40%			
13	Max load regulation (*6)	---	0.80%			
14	Output Ripple and noise pk-pk (*4)	mV	150	200	250	300
15	Temperature stability	---	0.05% of rated Vout for 8hrs after 30min warm-up. Constant line, load and temperature.			
16	Temperature coefficient	PPM/°C	200			
17	Remote sensing (*7)	V	Possible. Refer to Instruction Manual.			
18	Parallel operation (*9)	---	Possible. Refer to Instruction Manual.			
19	Series operation	---	Possible. Refer to Instruction Manual.			
20	Over current protection	---	105~125% of maximum output current. Refer to Fig. 1			
21	Over voltage protection (*8)	V	14.3~15.7	31~34	41.5~45.5	62~66
22	Over temperature protection	---	Inverter shut down method, automatic reset.			
23	Remote On/Off control	---	By electrical signal or dry contact. ON: 0~0.6V or short. OFF: 2~15V or open.			
24	DC OK signal	---	Open collector signal. On when Vout ≥ 80+/-5% rated output. Max.sink current: 10mA			
25	Over-Temp. warning	---	Open collector signal. Refer to Instruction Manual			
26	AC fail signal	---	Open collector signal. Refer to Instruction Manual			
27	Auxiliary power supply	---	11.2~12.5VDC. 0.25A Maximum output current.			
28	Vout voltage trimming	---	Possible, via Vout Trim pin in the I/O connector. Refer to Instruction Manual.			
29	Front panel indicators	---	AC OK, DC OK, DC FAIL			
30	I ² C Interface	---	Optional. Refer to Instruction Manual.			
31	Operating temperature-models without IEC inlet	---	0~50°C: 100% load. Derate 2%/°C, 50°C to 60°C, Derate 2.5%/°C, 60°C to 70°C.			
	models with IEC inlet	---	0~50°C: 100% load. Derate 2%/°C, 50°C to 60°C.			
32	Storage temperature	---	-30~85°C			
33	Operating humidity	---	10~90% RH, no condensation.			
34	Storage humidity	---	10~95% RH, no condensation.			
35	Cooling	---	By internal Fans. Variable speed control.			
36	Vibration	---	Built to meet ETS 300 019			
37	Shock	---	Built to meet ETS 300 019			
38	Conducted emission (*10)	---	EN55022B, FCC part 15J-B, VCCI-B			
39	Radiated emission	---	EN55022B, FCC part 15J-B, VCCI-B			
40	Applicable safety standards	---	UL60950-1, EN60950-1			
41	Withstand voltage	---	Input-Output: 3000Vrms, 1min. Input-Ground: 2000Vrms, 1min. Output-Ground: 500Vrms, 1min.			
42	Insulation resistance	---	More than 100Mohm at 25°C and 70% RH. Output-Ground: 500Vdc			
43	Leakage current	mA	Less Than 1.1mA at 230Vac			
44	Weight (Typ)	Kg	2.0			
45	Size (W*H*D)	---	127x41x290mm. Refer to Outline Drawing.			

Notes:

- *1: For cases where conformance to various safety standards (UL, EN etc.) is required, to be described as 100-240Vac (50/60Hz).
- *2: At 100/200Vac, rated load and 25°C ambient temperature.
- *3: Not applicable for the noise filter inrush current less than 0.2mS.
- *4: Measured with JEITA RC-9131A 1:1 probe, 20MHz B.W.
- *5: From 85~132Vac or 170~265Vac, constant load.
- *6: From No-load to Rated load, constant input voltage. Measured at the sensing point in Remote sense.
- *7: Remote sensing can compensate up to 1V drop on each load wire.
- *8: Inverter shut down method. Reset by AC voltage recycle or by On/Off control.
- *9: Derate Maximum output power by 10% for input voltage less than 100V_{RMS}.
- *10 For FPS 1000-12/P(S), when used not with FPS-S1U or FPS-T1U racks, an EMI suppressor clamp should be attached to the AC cable, as close as possible to the AC inlet, to meet class B.

Model	FPS1000-12	FPS1000-24	FPS1000-32	FPS1000-48
V1 (V)	12	24	32	48
V2 (V)	13.2	29	38.4	58
I1 (A)	66	33	26	17.25
I2 (A)	72	40	31	21

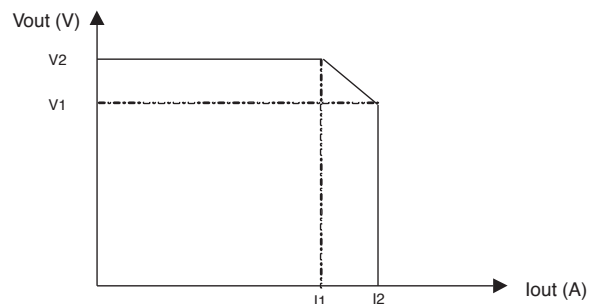
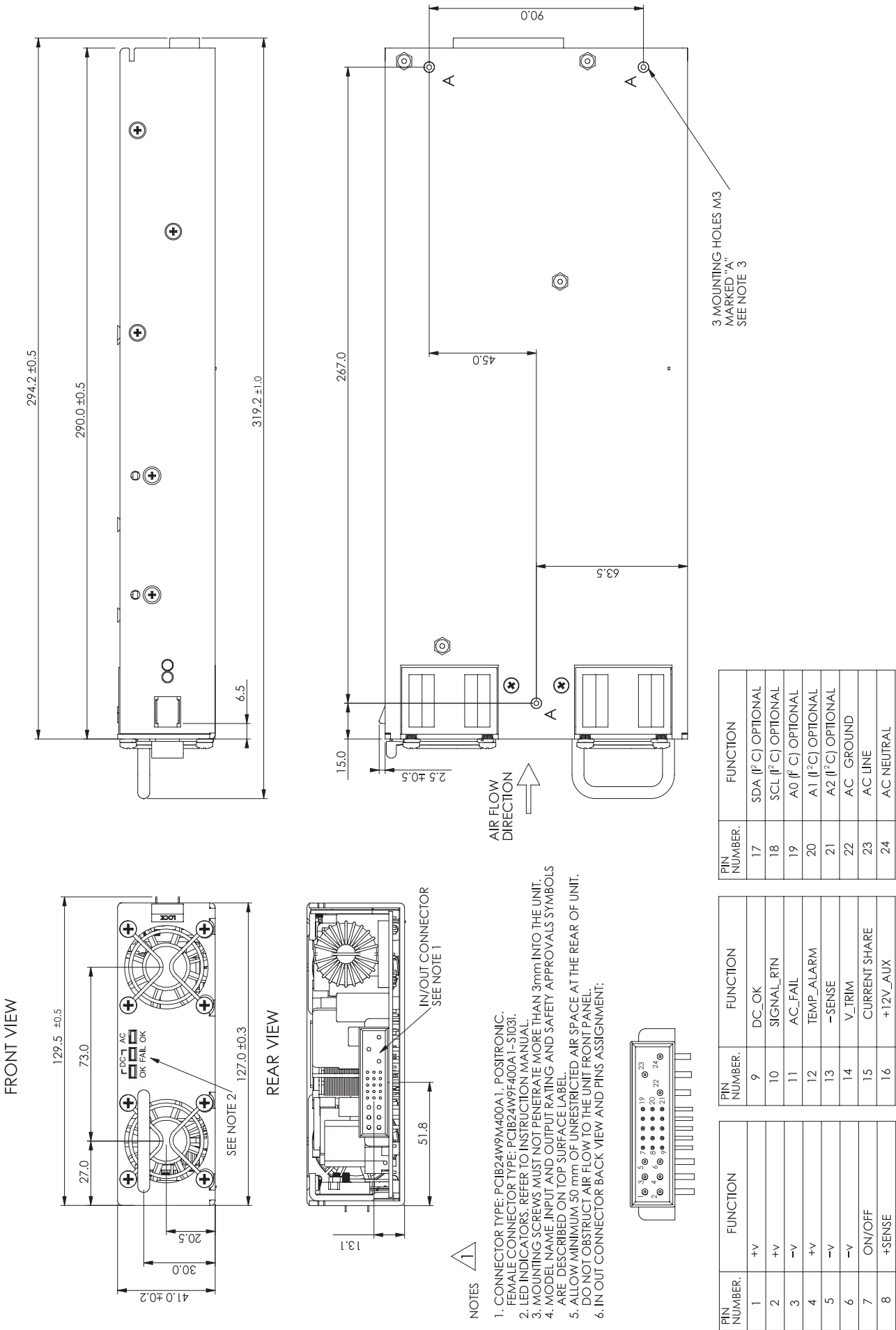

Fig. 1: Rated output current vs output voltage

CHAPTER 2 OUTLINE DRAWINGS
1.2 FPS 1000 SERIES OUTLINE DRAWINGS



PIN NUMBER.	FUNCTION
17	SDA (I ² C) OPTIONAL
18	SCL (I ² C) OPTIONAL
19	A0 (I ² C) OPTIONAL
20	A1 (I ² C) OPTIONAL
21	A2 (I ² C) OPTIONAL
22	AC GROUND
23	AC LINE
24	AC NEUTRAL

PIN NUMBER.	FUNCTION
9	DC_OK
10	SIGNAL_RTN
11	AC_FAIL
12	TEMP_ALARM
13	-SENSE
14	V_TRIM
15	CURRENT_SHARE
16	+12V_AUX

PIN NUMBER.	FUNCTION
1	+V
2	+V
3	-V
4	+V
5	-V
6	-V
7	ON/OFF
8	+SENSE

2.2 FPS 1000/P SERIES OUTLINE DRAWINGS

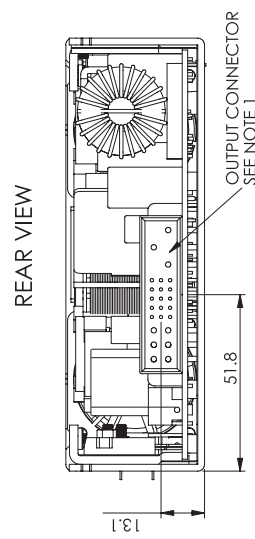
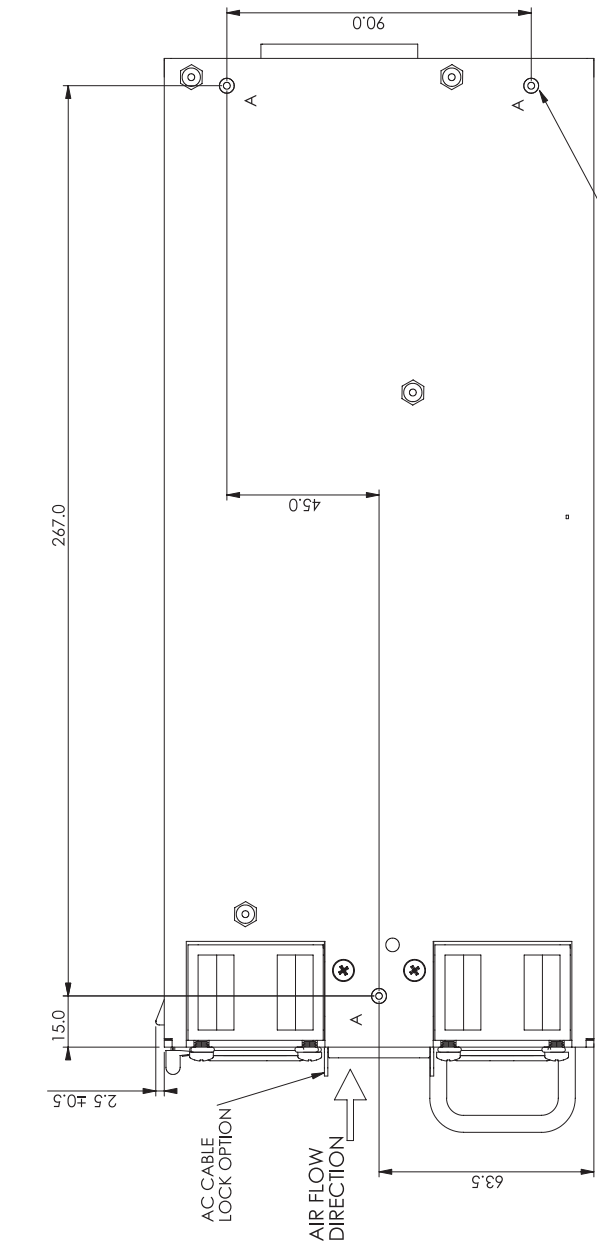
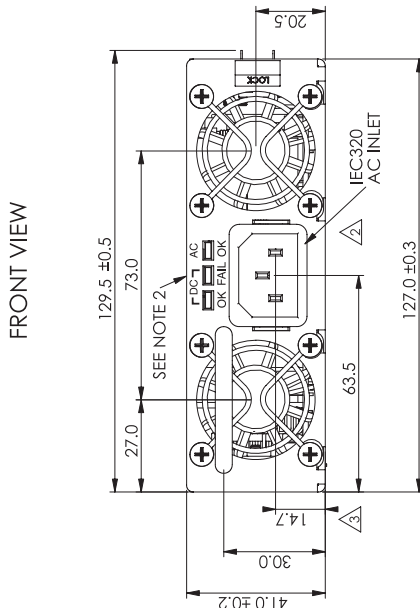
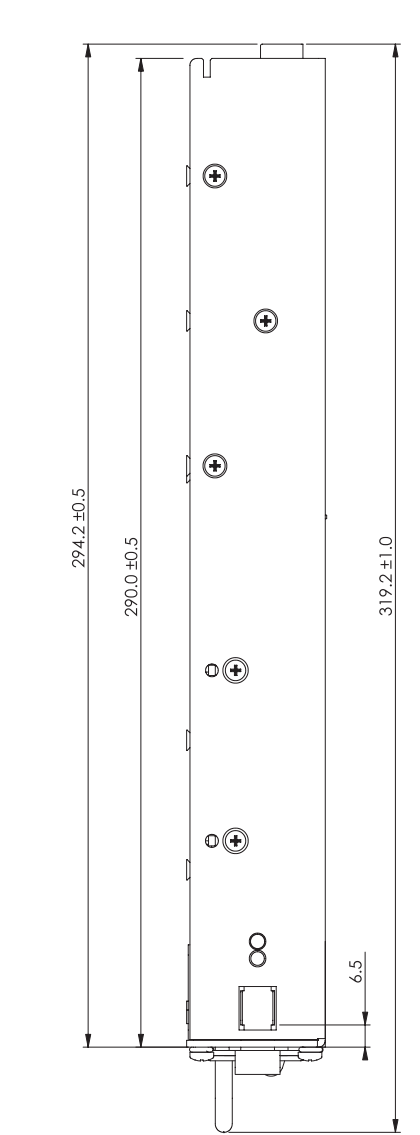

- NOTES
- CONNECTOR TYPE: PCB24W9M400A1, POSITRONIC. FEMALE CONNECTOR TYPE: PCB24W9F400A1 - S1031.
 - LED INDICATORS: REFER TO INSTRUCTION MANUAL.
 - MOUNTING SCREWS MUST NOT PENETRATE MORE THAN 3mm INTO THE UNIT.
 - MODEL NAME INPUT AND OUTPUT RATING AND SAFETY APPROVALS SYMBOLS ARE DESCRIBED ON TOP SURFACE LABEL.
 - ALLOW MINIMUM 50 mm OF UNRESTRICTED AIR SPACE AT THE REAR OF UNIT. DO NOT OBSTRUCT AIR FLOW TO THE UNIT FRONT PANEL.
 - IN OUT CONNECTOR BACK VIEW AND PINS ASSIGNMENT:

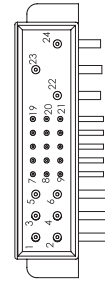

3 MOUNTING HOLES M3 MARKED "A" SEE NOTE 3

PIN NUMBER	FUNCTION
17	SDA (I ² C) OPTIONAL
18	SCL (I ² C) OPTIONAL
19	A0 (I ² C) OPTIONAL
20	A1 (I ² C) OPTIONAL
21	A2 (I ² C) OPTIONAL
22	NC
23	NC
24	NC

PIN NUMBER	FUNCTION
9	DC_OK
10	SIGNAL_RTN
11	AC_FAIL
12	TEMP_ALARM
13	-SENSE
14	V_TRIM
15	CURRENT SHARE
16	+12V_AUX

PIN NUMBER	FUNCTION
1	+V
2	+V
3	-V
4	+V
5	-V
6	-V
7	ON/OFF
8	+SENSE

CHAPTER 3 FPS1000 POWER SUPPLY INSTALLATION

3.1 GENERAL

This chapter contains instructions for initial inspection, preparation for use and repackaging for shipment.

NOTE

FPS1000 power supplies series generate magnetic field which might affect the operation of other instruments. If your equipment is susceptible to magnetic fields, do not position it adjacent to the FPS1000 unit.

3.2 PREPARATION FOR USE

In order to be operational the power supply must be connected to an appropriate AC source.

The AC source voltage should be within the power supply specification. Do not apply power before reading sections 3.6 and 3.7.

Table 3-1 below describes the basic setup procedure. Follow the instructions in Table 3-1 in the sequence given to prepare the power supply for use.

Step no	Item	Description	Reference
1	Inspection	Initial physical inspection of the power supply	Section 3.3
2	Installation	Installing the power supply. Ensuring adequate ventilation.	Section 3.4 Section 3.5
3	AC source	AC source requirements	Section 3.6
4	Load connection	Wire size selection. Local / Remote sensing. Single or multiple loads.	Section 3.7

Table 3-1: Basic setup procedure

3.3 INITIAL INSPECTION

Prior to shipment this power supply was inspected and found free of mechanical or electrical defects.

Upon unpacking of the power supply, inspect for any damage which may have occurred in transit.

The inspection should confirm that there is no exterior damage to the power supply.

Keep all packing material until the inspection has been completed. If damage is detected, file a claim with carrier immediately and notify the Lambda sales or service facility nearest you.

3.4 FPS1000 MOUNTING

The FPS1000 power supplies series is designed to fit in the FPS-S1U and FPS-T1U, 19" rack, or in an equivalent rack designed for the FPS1000 power supply.

The FPS1000 is secured to the rack using the spring lock device, located at the FPS1000 front panel. Refer to the FPS1000 and the FPS-S1U and FPS-T1U outline drawings in Chapter 2, Chapter 11 and Chapter 18.

When installation using mounting screws is required, the FPS1000 can be secured to the equipment using the M3 mounting holes at its bottom surface. Refer to the FPS1000 outline drawings.

3.5 LOCATION MOUNTING AND COOLING

This power supply is fan cooled. The air intake is at the front panel and the exhaust is at the rear panel.

Upon installation allow cooling air to reach the front panel ventilation inlets and allow minimum 50mm of unrestricted air space at the rear of the unit for the air exhaust.

3.6 AC SOURCE REQUIREMENTS

The FPS1000 series can be operated from a nominal 100V to 240V, single phase, 47~63Hz. Refer to the specifications in chapter 1 for the input voltage range and the current required.

Ensure that under heavy load, the AC voltage supplied to the power supply does not fall below the "low limit" specifications.

CAUTION

Connection of this power supply to an AC power source should be made by an electrician or other qualified personnel.

WARNING

There is a potential shock hazard if the power supply chassis and cover are not connected to an electrical safety ground via the safetyground in the AC input connector.

3.7 CONNECTING THE LOAD

WARNING

Turn off the AC input power before making or changing any rear panel connection. Ensure that all connections are securely tightened before applying power. There is a potential shock hazard when using a power supply with a rated output greater than 40V.

3.7.1 Load Wiring.

The following considerations should be made to select wiring for connecting the load to the power supply:

- * Current carrying capacity of the wire (refer to 3.7.2).
- * Insulation rating of the wire should be at least equivalent to the maximum output voltage of the power supply.
- * Maximum wire length and voltage drop (refer to 3.7.2).
- * Noise and impedance effects of the load wiring (refer to 3.7.3).

3.7.2 Current Carrying Capacity

Two factors should must be considered while selecting the wire size. 1.Wires should be at least heavy enough not to overheating while carrying the power supply load current at the rated load, or the current that would flow in the event the load wires were shorted, whichever is greater. 2.Wire size should be selected to enable voltage drop per lead to be less than 1.0V at the rated current. Please refer to Tables 3-2 and 3-3 for maximum wire length to limit the voltage drop in American and European dimensions respectively.

wire size AWG	Resistivity Ohm/kft	Maximum length in Feet to limit voltage drop to 1V or less.				
		5A	10A	20A	50A	150A
14	2.526	80	40	20	8	2
12	1.589	120	60	30	12	3.4
10	0.9994	200	100	50	20	6
8	0.6285	320	160	80	32	10
6	0.3953	500	250	125	50	16
4	0.2486	800	400	200	80	26
2	0.1564	1200	600	300	125	40
0	0.0983	2000	1000	500	200	68

Table 3-2:Maximum wire length for 1V drop on lead (in feet).

Cross sect. Area (mm ²)	Resistivity Ohm/km	Maximum length in meters to limit voltage drop to 1V or less.				
		5A	10A	20A	50A	150A
2.5	8.21	24.0	12.0	6.0	2.4	0.8
4	5.09	39.2	18.6	9.8	4.0	1.4
6	3.39	59.0	29.4	14.8	5.8	2.0
10	1.95	102.6	51.2	25.6	10.2	3.4
16	1.24	160.0	80.0	40.0	16.0	5.4
25	0.795	250.0	125.0	62.0	25.2	8.4
35	0.565	354.0	177.0	88.0	35.4	11.8

Table 3-3:Maximum wire length for 1V drop on lead (in meters).

For currents not shown in Tables 3-2 and 3-3 , use the formula :

$$\text{Maximum length} = 1000 / (\text{current} * \text{resistivity})$$

Where current is expressed in amperes and resistivity in ohms/km or ohms/1000ft.

3.7.3 Noise and Impedance Effects

To minimize the noise pickup or radiation, the load wires and remote sense wires should be twisted-pairs of the shortest possible length. Shielding of the sense leads may be necessary in high noise environments.

Even if noise is not a concern, the load and remote sense wires should be twisted-pairs to reduce coupling between them, which might impact the stability of power supply. The sense leads should be separated from the power leads.

Twisting the load wires reduces the parasitic inductance of the cable which could produce high frequency voltage spikes at the load and the output of power supply because of current variation in the load itself.

The impedance introduced between the power supply output and the load could make the ripple and noise at the load worse than the noise at the power supply rear panel output. Additional filtering with bypass capacitors at the load terminals may be required to bypass the high frequency load current.

3.7.4 Inductive loads

To prevent damage to the power supply from inductive kickback, a diode should be connected across the output. The diode voltage and current rating should be greater than the power supply maximum output voltage and current rating. Connect the cathode to the positive output and the anode to the negative output. Where positive load transients such as back EMF from a motor may occur, connect a surge suppressor across the output to protect the power supply. The breakdown voltage rating of the suppressor must be approximately 10% higher than the maximum output voltage of the power supply.

3.7.5 Making the load connections



WARNING

Hazardous voltages may exist at the outputs and the load connections when using a power supply with a rated output greater than 40V. To protect personnel against accidental contact with hazardous voltages, ensure that the load and its connections has no accessible live parts. Ensure that the load wiring insulation rating is greater than or equal to the maximum output voltage of the power supply.

3.7.6 Front panel controls and indicator

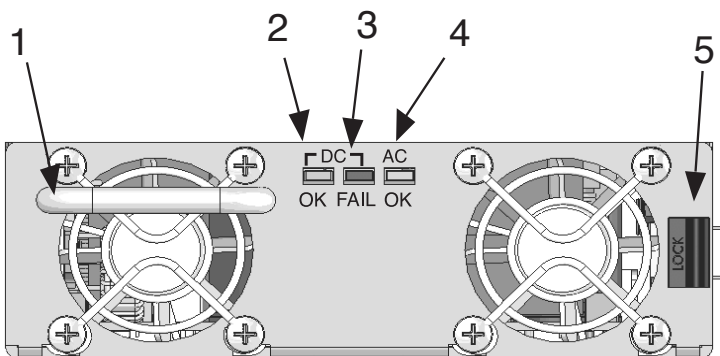

Fig. 3-1: FPS1000 front panel

- 1: Handle
- 2: DC OK green LED, on when the output voltage is above 80% +/- 5% of its rated value.
- 3: DC Fail red LED, on when the output voltage is lower than 80% +/- 5% of its rated value.
- 4: AC OK green LED, on when the input voltage is higher than 85Vrms
- 5: Lock/Unlock lever. Automatically locks the power supply to the FPS-S1U rack chassis when the FPS1000 power supply is inserted. Push the Lock/Unlock lever toward the power supply cooling fan to withdraw the FPS1000 from the rack.
- 6: IEC320 AC inlet

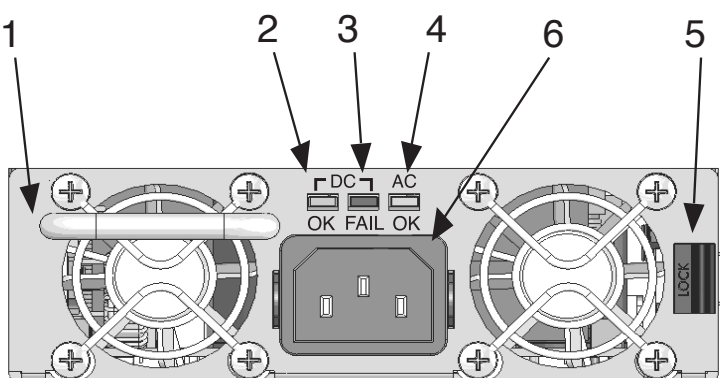

Fig. 3-2: FPS1000/P front panel

3.7.7 Input/Output connector information

The FPS1000 series uses male connector PCIB24W9M400A1, Positronic connector. To mate FPS1000 series to the load circuitry, use female connector PCIB24W9F400A1-S1031, Positronic connector. Refer to Table 3-4 and to the Outline drawing in chapter 2 for the connector pinout description.

Pin No	Function	Description
1,2,4	+V	Positive output voltage. Maximum current capacity: 24A/contact.
3,5,6	-V	Negative output voltage. Maximum current capacity: 24A/contact.
7	On/Off control	Turns the output to On and Off by electrical signal or dry contact between pin 7 and pin 10 (Signal Return). 0~0.6V or Short: On, 2~15V or Open: Off. The maximum source current is 2.6mA.
8	+Sense	Positive sensing. The +Sense signal should be connected to the positive terminal of the load. The +Sense and -Sense leads should be twisted pair to minimize noise pick-up effect. The maximum load wires drop compensation is 1V/wire.
9	DC_OK	Open collector signal, referenced to pin 10 (Signal Return). On when $V_{out} \geq 80\% \pm 5\%$ of its rated value. The maximum sink current is 10mA and the maximum external voltage is 15V.
10	Signal_Return	Return for the following control and supervisory signals: On/Off, DC_OK, Over_temperature Alarm, AC_Fail, Auxiliary 12V supply. The Signal return is isolated from the output terminals.
11	AC_Fail	Open collector signal, referenced to pin 10 (Signal Return). On when the input voltage is $\geq 85V_{rms}$. The maximum sink current is 10mA and the maximum external voltage is 15Vdc.
12	Over Temperature Alarm	Open collector signal, referenced to pin 10 (Signal Return). On when the internal temperature is within safe limit, Off approx. 10°C below Thermal shut down. The maximum sink current is 10mA and the maximum external voltage is 15V.
13	-Sense	Negative sensing. The -S signal should be connected to the negative terminal of the load. The -S and +S leads should be twisted pair to minimize noise pick-up effect. The maximum load wires drop compensation is 1V/wire.
14	V_Trim	Connection for output voltage trimming. The voltage can be trimmed within its range specifications.
15	CS	Current sharing signal. When units are connected in parallel, the CS pins of the units should be connected to allow current balance between units.
16	+12V Auxiliary	Auxiliary voltage output, 11.2~12.5V, referenced to pin 10 (Signal Return). The maximum load current is 0.25A. This output has built in Oring diode and is not controlled by the On/Off control.
17	SDA	Serial Data used in the I ² C interface option. Refer to the I ² C interface description.
18	SCL	Serial Clock used in the I ² C interface option. Refer to the I ² C interface description.
19,20,21	A0, A1, A2	I ² C interface address lines. Refer to the I ² C interface description in Chapter 7.
22	ACG	AC Ground connection, refer to the safety instructions for safety standards requirements. For "/P" models the AC Ground is connected via the front panel IEC inlet.
23	AC Line	AC Line connection, refer to the safety instructions for safety standards requirements. For "/P" models the AC Line is connected via the front panel IEC inlet.
24	AC Neutral	AC Neutral connection, refer to the safety instructions for safety standards requirements. For "/P" models the AC Neutral is connected via the front panel IEC inlet.

Table 3-4: Rear In/Out connector pins function description

3.7.8 REPACKAGING FOR SHIPMENT

The original packaging material is reusable. If the original package is not available, contact the Lambda Sales or service facility near you for details on obtaining suitable packaging and shipping information. To ensure safe transportation of the instrument, it is recommended to use the original package. Please attach a tag to the power supply describing the problem and specifying the owner, model number and serial number of the power supply.

CHAPTER 4 FUNCTIONS AND FEATURES

4.1 Input Voltage Range

Input voltage is single phase 85~265Vac (47~63Hz). The power supply can be operated also with a DC input voltage, 120~330VDC but the safety approvals apply to the AC voltage only. Input voltage which is out of the specifications might cause damage to the unit.

4.2 Output voltage trimming

The output voltage can be adjusted within the specifications via the V_Trim pin at the In/Out connector. Refer to Fig 4-1 typical connection and calculation of the adjustment resistors:

Note that the Over Voltage Protection may trigger if the output voltage exceeds the maximum voltage specification.

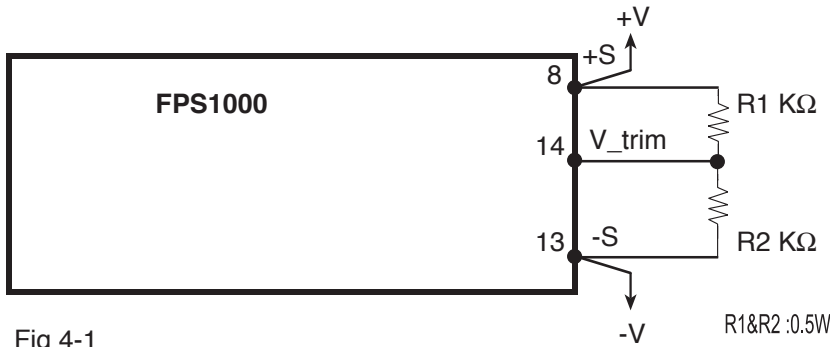

FPS1000-12:
 $R2 = 0.0324 * V_{out}^2 - 1.1298 * V_{out} + 9.9342$
 $R1(K\Omega) = 5(K\Omega) - R2(K\Omega)$

FPS1000-24:
 $R2 = 0.0785 * V_{out}^2 - 5.819 * V_{out} + 105.132$
 $R1(K\Omega) = 20(K\Omega) - R2(K\Omega)$

FPS1000-32:
 $R2 = 0.0463 * V_{out}^2 - 4.5805 * V_{out} + 109.49$
 $R1(K\Omega) = 20(K\Omega) - R2(K\Omega)$

FPS1000-48:
 $R2 = 0.0497 * V_{out}^2 - 7.2795 * V_{out} + 259.04$
 $R1(K\Omega) = 50(K\Omega) - R2(K\Omega)$

Fig 4-1

4.3 Over Voltage Protection (OVP)

The OVP triggers when the output voltage exceeds the maximum rating and reaches the OVP limit. When the OVP is triggered, the output voltage shuts down. In order to resume operation, the AC input voltage should be removed for more than 30 sec. The OVP level is factory set and is not adjustable.

4.4 Over Current Protection (OCP)

A constant current limiting with automatic recovery is provided. The OCP operates when the output current exceeds 105%~125% of the rated output current. The output voltage recovers automatically when the overload condition is removed. Avoid operating the power supply under overload condition for long time as it might cause damage to the power supply.

4.5 Over Temperature Protection (OTP)

The OTP is activated when the ambient temperature or the power supply internal temperature exceeds a safe temperature. When the OTP is activated, the power supply output shuts down. The output recovers automatically when the ambient temperature or the internal temperature cools to a safe limit.

4.6 Auxiliary 12V output

An isolated 11.2V~12.5V output is provided (Referenced to the Signals_Return potential). The maximum output current from this output is 0.25A. This output has a built-in Oring diode to allow paralleling FPS1000 units. Use this output for the control and monitoring signals described in this chapter or to operate application circuits.

4.7 Over Temperature Alarm

An open collector output provides an Over Temperature Alarm approx. 10°C below shut down by the OTP. The open collector output is referenced to the Signals_Return potential and is isolated from the power supply +V and -V terminals

The maximum sink current is 10mA and the maximum external voltage is 15V.

Refer to Fig 4-2 for typical application.

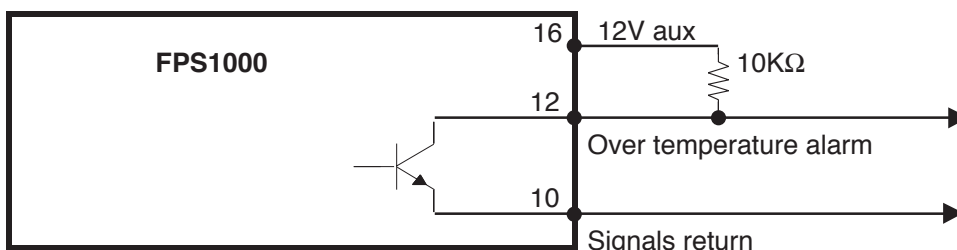

Fig 4-2

4.8 DC_OK signal

An open collector output provides a low output voltage detection signal. The open collector output is on when the output voltage is higher than 80%+/-5% of the rated output voltage of the power supply.

The open collector output is referenced to the Signals_Return potential and is isolated from the power supply +V and -V terminals

The maximum sink current is 10mA and the maximum external voltage is 15V.

Refer to Fig 4-3 for typical application.

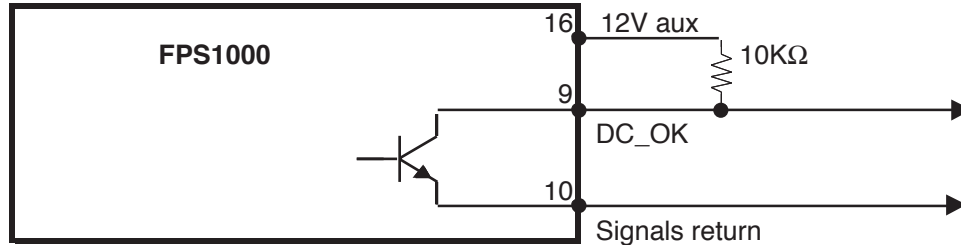

Fig 4-3

4.9 AC_Fail signal

An open collector output provides a low AC input voltage detection signal. The open collector output is on when the input voltage is 85Vac or higher.

The open collector output is referenced to the Signals_Return potential and is isolated from the power supply +V and -V terminals

The maximum sink current is 10mA and the maximum external voltage is 15V.

Refer to Fig 4-4 for typical application.

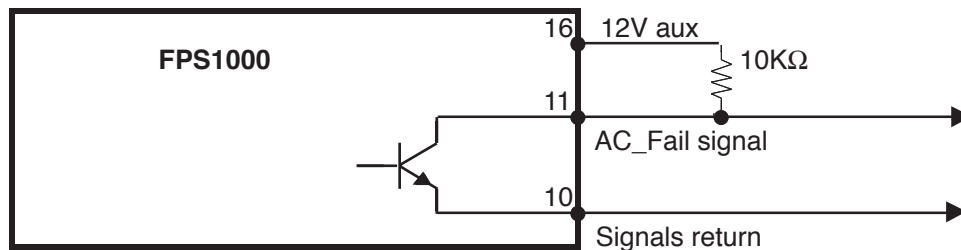

Fig 4-4

4.10 Remote On/Off control

A Remote On/Off control input is provided. The Remote On/Off input is isolated from the power supply +V and -V terminals and is referenced to the Signals_Return potential. The Remote On/Off can be operated either by electrical signal or by dry contact.

(1) Operation by electrical signal:

0~0.6V: Output is On.

2~15V: Output is Off.

The maximum sink current is 2.6mA and the maximum external voltage is 15V.

(2) Operation by dry contact (relay or switch):

Short between On/Off input and Signals Return: Output is On.

Open circuit between On/Off input and Signals Return: Output is Off.

When the Remote On/Off function is not used, connect a short circuit between the On/Off control and the Signals_Return.

Refer to Fig 4-5 for the remote On/Off circuit description:

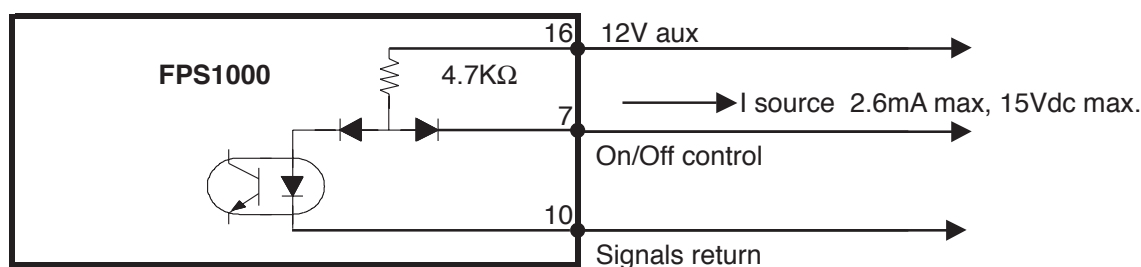

Fig 4-5

4.11 Remote Sensing

The Remote sensing compensates voltage drop on the load wiring. The maximum voltage drop on each wire is 1V, however, it is recommended to minimize the voltage drop on the load wires to improve the response to load current changes.

In case that the sensing wires are long, use separate twisted pair wires for the sensing and for the load wires to minimize noise pick-up.

It is recommended to connect electrolytic capacitors in the following locations:

- 1) Across the load terminals
- 2) Between the "+S" terminal and the "+V" terminal of the power supply.
- 3) Between the "-S" terminal and the "-V" terminal of the power supply.

Refer to Fig 4-6 for typical connection of remote sensing.

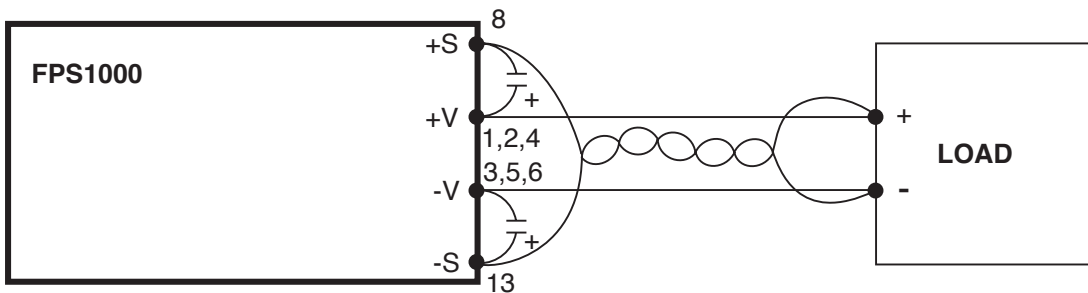

Fig 4-6

CHAPTER 5 BASIC CONNECTIONS FOR OPERATION

5.1 Connecting single load, Local sensing

Local sensing is suitable for applications where load regulation is not critical. Fig 5-1 shows recommended load and sensing connections for applications with a single load.

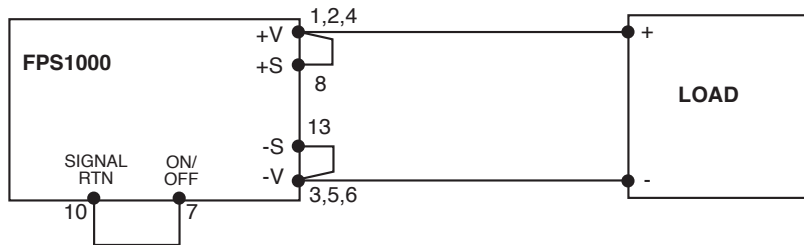

Fig 5-1: single load connection, local sensing

* In Local sense applications, the +/- sense have to be connected to the +/-V terminals of the FPS1000 units prior the operating the FPS1000 units

5.2 Connecting Single Load, Remote Sensing

Remote sensing is used in cases where the load regulation is important at the load terminals. Use twisted or shielded wires to minimize noise pick-up. If shielded wires are used, the shield should be connected to the ground at one point, either the power supply side or the load. The optimal point for the shield ground should be determined by experimentation. Refer to the power supply specifications for the maximum voltage drop allowed at the load wires.

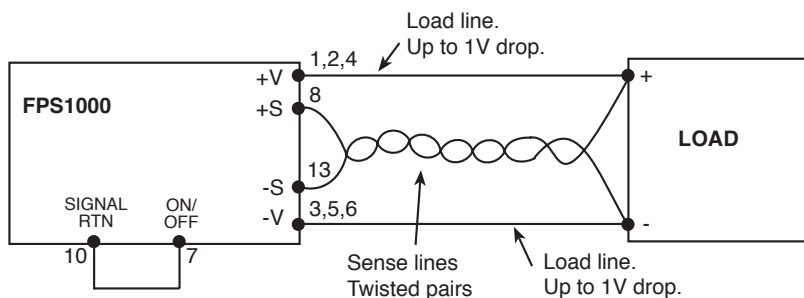

Fig 5-2: Remote sensing, single load.

5.3 Connecting Multiple loads, radial distribution method

In cases of multiple loads connected to one supply, each load should be connected to the power supply's output terminals using separate pairs of wires. It is recommended that each pair of wires will be as short as possible and twisted or shielded to minimize noise pick-up and radiation.

The sense wires should be connected to the power supply output terminals or to the load with the most critical load regulation requirement.

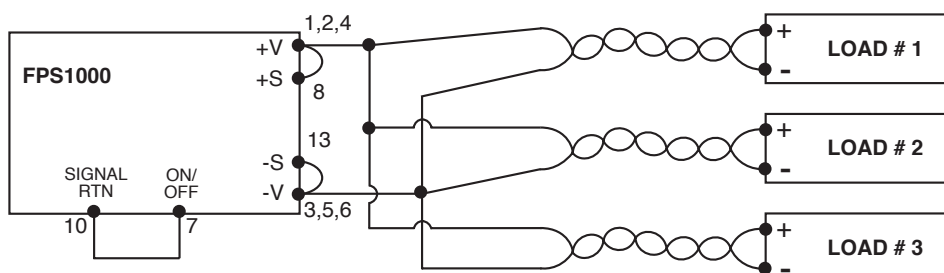

Fig 5-3: Multiple loads connection , radial distribution

5.4 Multiple loads connection with distribution terminals

If remotely located output distribution terminals are used, the power supply output terminals should be connected to the distribution terminals by a pair of twisted or shielded wires. Each load should be separately connected to the remote distribution terminals (see Fig 5-4). If remote sensing is required, the sensing wires should be connected to the distribution terminals or at the most critical load.

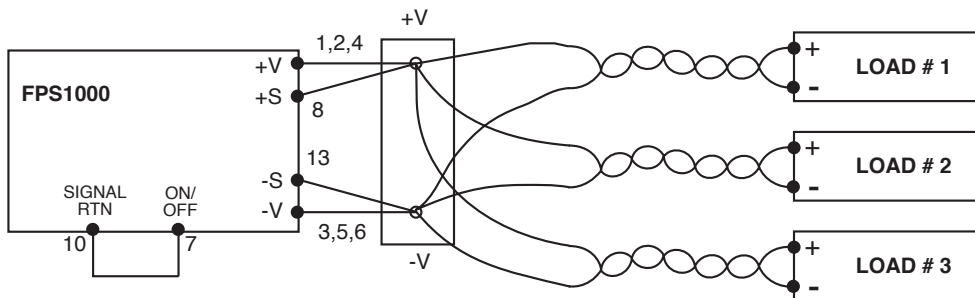

Fig 5-4: Multiple loads connection with distribution terminal

5.5 Grounding outputs

Either the positive or negative output terminals can be grounded. To avoid noise problems caused by common-mode current flowing from the load to ground, it is recommended to ground the output terminal as close as possible to the power supply's output. Always use two wires to connect the load to the power supply regardless of how the system is grounded.

CHAPTER 6 PARALLEL AND SERIES OPERATION

6.1 Parallel operation

Up to 8 FPS1000 units of the same output voltage rating can be connected in parallel. By connecting the CS signal between the paralleled units, automatic current balance is achieved, with +/-10% accuracy. Derate the total output current by 10% when using parallel operation to prevent overload condition.

The built-in Oring diodes on the main output and the 12V Auxiliary output allow N+1 operation.

For input voltages less than 100Vac, maximum output Power derated by 10% of the Power rating.

6.1.1 Parallel operation with Remote sensing

Fig 6-1 shows typical connection of parallel operation with Remote sensing. The CS signal wires should be as short as possible and with the same length.

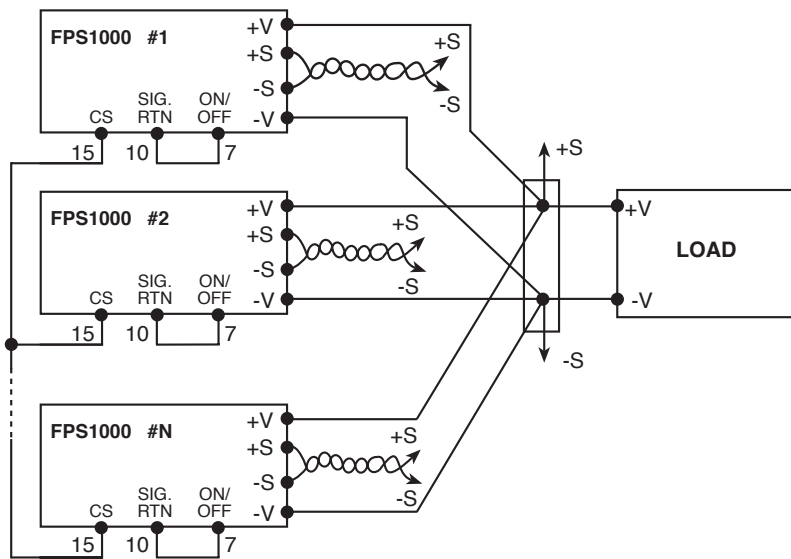
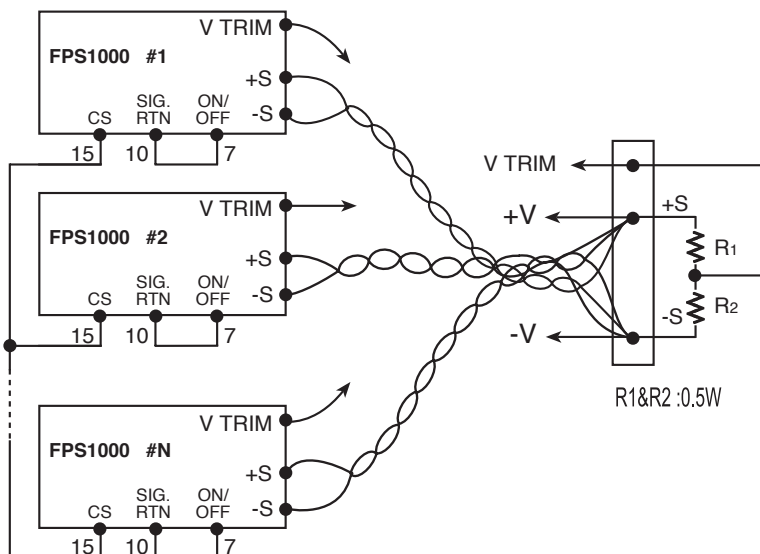

Fig 6-1: Parallel operation with Remote sensing

6.1.2 Output voltage trimming at parallel operation

The output voltage of the units connected in parallel can be made by a single trimmer or resistive divider as shown in Fig 6-2.



FPS1000-12:
 $R2=0.0324 \cdot V_{out}^2 - 1.1298 \cdot V_{out} + 9.9342$
 $R1(K\Omega)=5(K\Omega)-R2(K\Omega)$

FPS1000-24:
 $R2=0.0785 \cdot V_{out}^2 - 5.819 \cdot V_{out} + 105.132$
 $R1(K\Omega)=20(K\Omega)-R2(K\Omega)$

FPS1000-32:
 $R2=0.0463 \cdot V_{out}^2 - 4.5805 \cdot V_{out} + 109.49$
 $R1(K\Omega)=20(K\Omega)-R2(K\Omega)$

FPS1000-48:
 $R2=0.0497 \cdot V_{out}^2 - 7.2795 \cdot V_{out} + 259.04$
 $R1(K\Omega)=50(K\Omega)-R2(K\Omega)$

Fig 6-2: Output voltage trimming at parallel operation

6.1.3 Signal Return bus at parallel operation

The Signal Return of each paralleled unit can be connected together to form a common Signal Return bus. By this way, the control and monitoring signals of the paralleled units can be connected to the same control and monitoring circuitry.

The Signal Return bus can be connected to the -V or -S or +V or -S or float. Fig 6-3 shows typical connection of the Signal Return at parallel operation.

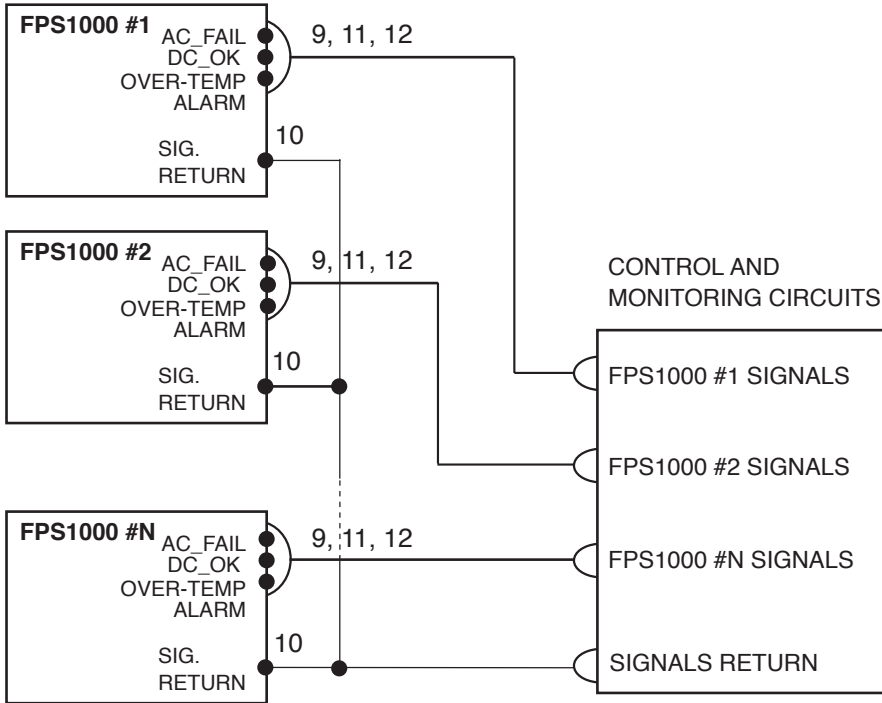

Fig 6-3: Signal Return connection at parallel operation

6.1.4 Remote On/Off control at parallel operation

The paralleled units can be turned On or Off via a single On/Off control. Refer to Fig 6-4 for typical application. The Signal Return function of all the paralleled units should be connected together to create a common Signal Return bus. The Signal Return bus may be connected to the -V or the +V potential or floated. In any case do not connect the Signal Return bus to different potentials.

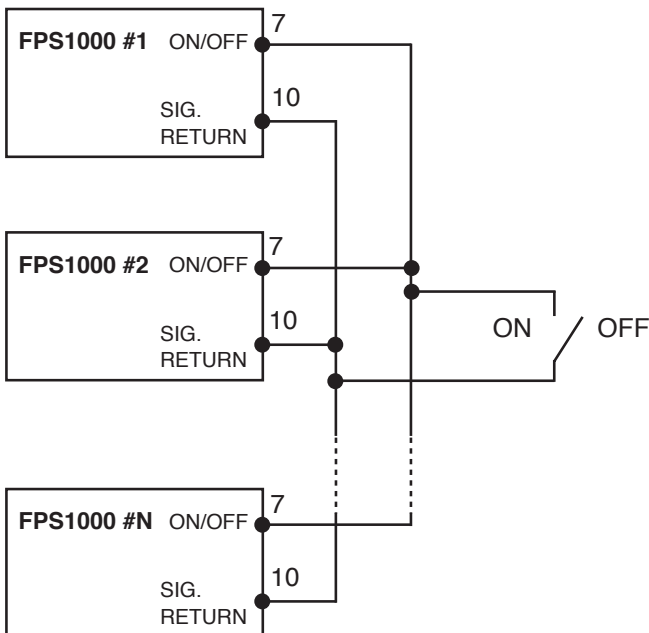

Fig 6-4: Remote On/Off control at parallel operation

6.2 Series operation

Two units can be seriesly connected to increase the output voltage or to create a bipolar voltage source. It is recommended to connect diodes in parallel with each output to prevent reverse voltage in case of failure in one of the power supplies. Each diode should be rated to at least the power supply rated output voltage and output current. Refer to Fig 6-5 and 6-6 for typical Iseries connection of power supplies.

Series connection for increased output voltage.

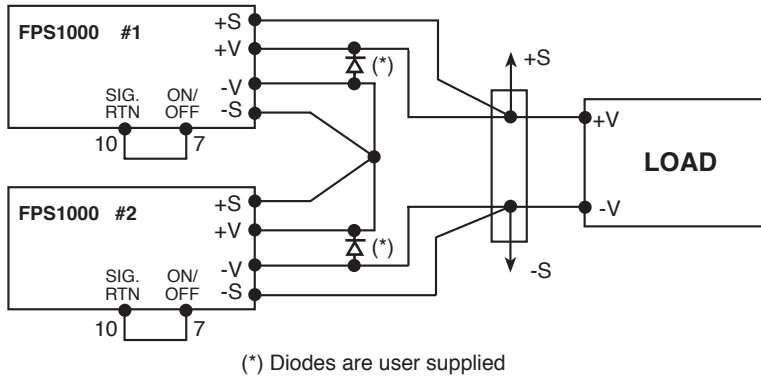

Fig 6-5: Series connection for increased output voltage

Series connection for positive and negative output voltage.

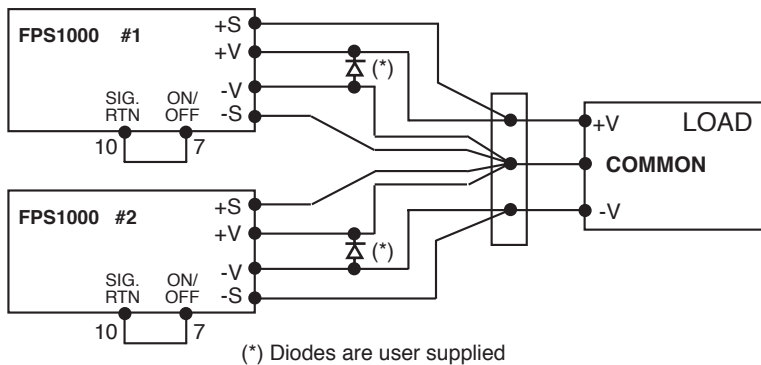

Fig 6-6: Series connection for Bipolar output voltage

CAUTION

Series operation is not applicable for units with I²C bus option.

CHAPTER 7 I²C BUS INTERFACE OPTION

7.1 Introduction

The I²C interface option includes facilities to monitor operating parameters of the power supply. The parameters are then transferred to the host PC if demanded, over a standard I²C bus.

The following data can be monitored for the individual units connected to the I²C bus:

1. Status of the unit.
2. Actual output voltage, output current and internal temperature of the unit.
3. Manufacturing related data (model, serial number, manufacturing date etc...).

7.1.1 Addressing (A0, A1, A2).

Three address lines allow up to eight FPS1000 units to be addressed on a single I²C bus. The address lines are internally pulled-up to +5V by resistors. Addressing of a unit is achieved by hard-wiring an address line to the -Sense to set it to "0" or leaving the address line open to set it to "1".

7.1.2 Serial clock

This line is clocked by the processor which controls the I²C bus. It should be connected to +5V (referenced to -Sense) via a pull-up resistor of 2KΩ. The I²C interface is designed to run with a serial clock speed of 100KHz.

7.1.3 Serial data This line is a bidirectional data line. It should be connected to +5V (referenced to -Sense) via a pull-up resistor of 2KΩ.

7.2 I²C Interface Specifications

7.2.1 General specifications

- | | |
|---------------------|--|
| 1. Clock frequency: | 100KHz |
| 2. Address lines: | Three (A0, A1, A2). Support 8 power supply modules |

7.2.2 Output voltage measurement

- | | |
|----------------------------|--|
| 1. Measurement accuracy: | +/-2% of full scale |
| 2. Measurement resolution: | 8 bits |
| 3. Measurement range: | 0~60.0V for 48V model / 0~40.0V for 32V model / 0-30.0V for 24V model. |

7.2.3 Output current measurement

- | | |
|----------------------------|--|
| 1. Measurement accuracy: | +/-10% of full scale |
| 2. Measurement resolution: | 8 bits |
| 3. Measurement range: | 0~25.0A for 48V model / 0~50A for 32V & 24V models |

7.2.4 Internal temperature measurement

- | | |
|----------------------------|---------|
| 1. Measurement accuracy: | +/-3°C |
| 2. Measurement resolution: | 8 bits |
| 3. Measurement range: | 0-100°C |

7.2.5 EEPROM

- | | |
|-----------------|--|
| 1. EEPROM type: | AT24C02AN-10S , Atmel, or equivalent |
| 2. EEPROM data: | Model name, Serial no., Revision, Manufacture. Name, Output voltage, Date, Country of manufacturing, Check-Sum |

7.2.6 Status register

- | | |
|----------------------|--|
| 1. Register type: | PCF8574, Philips, or equivalent. |
| 2. Register content: | DC Fail, Over-Temperature Protection (OTP)
Temperature Alarm, Fan Fail, AC Fail |

CAUTION

The I²C bus address lines, serial clock and data are referenced to the -Sense potential. When using series connection of FPS1000 units, do not connect the I²C lines of the units together.

7.3 Block diagram of the I²C option

Refer to Fig 7-1 for description of the I²C block diagram and for typical application.

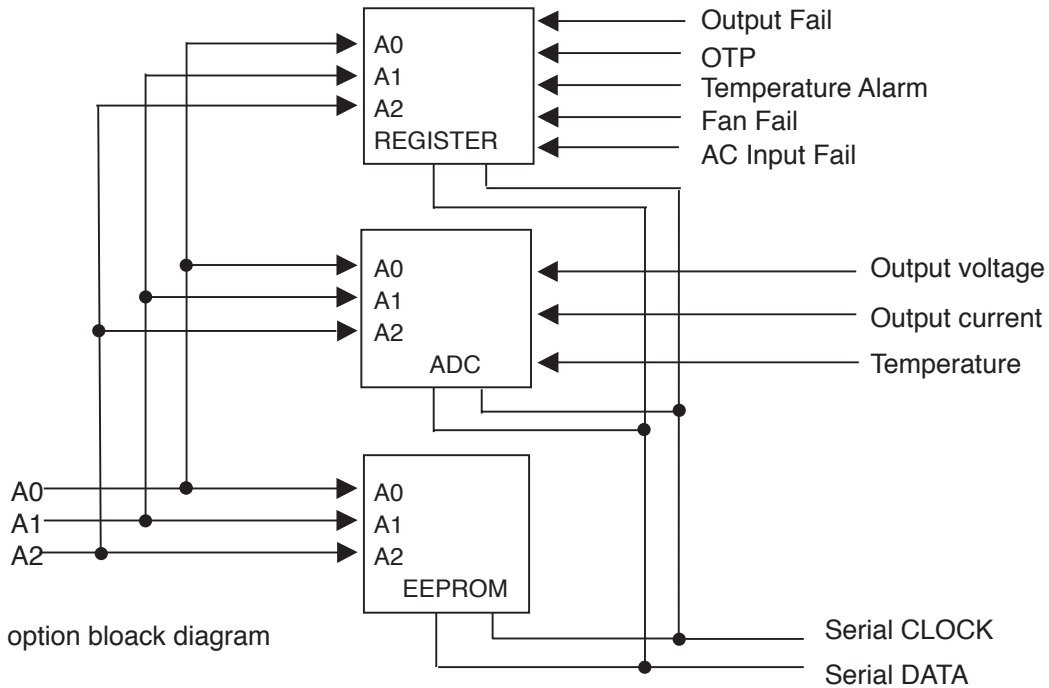

Fig 7-1: I²C option block diagram

7.4 Operation and functions

7.4.1. Digital status

Digital status functions are provided by a PCF8574, 8-bit Register. It provides a single 8-bit word when read by the I²C controller. Fault is indicated by "1" and Good level is indicated by "0".

Refer to Table 7-1 for the register information.

BIT	FUNCTION	MEANING
0	Output Fail	Output voltage is <80% +/- 5% of Vout rated
1	Over Temperature Protection	Internal temperature is over 80°C. Supply turns off.
2	Temperature Alarm	Internal temperature is over 70°C. Supply is on.
3	Fan Fail	Failure of an internal fan.
4	AC Input Fail	AC Input <85Vac
5	Not Used	Always "0".
6	Not Used	Always "0".
7	Not Used	Always "0".

Table 7-1

PCF8574 slave address:

Bit	7	6	5	4	3	2	1	0
Value	0	1	0	0	A2	A1	A0	R/W

7.4.2 EEPROM functions

A 256 bytes EEPROM included in the I²C option. The EEPROM type is AT24C02 and it is programmed at the factory with the data shown in Table 7-2.

ADDRESS	BYTES	DATA
0	4	Number of fields
4	16	Manufacturer
20	20	Serial number
40	16	Revision
56	16	Country of manufacture
72	16	Model name
88	16	Output voltage
104	16	Date of manufacture
254	2	Checksum

Table 7-2

The slave EEPROM address is:

Bit	7	6	5	4	3	2	1	0
Value	1	0	1	0	A2	A1	A0	R/W

7.4.3 Analog functions

Analog functions are provided by a single PCF8591, 4-channel 8-bit A/D converter. When this device is read by the serial buscontroller it provides an 8-bit word with the following information:

Channel 1: Output voltage, channel 2: Output current, channel 3: Internal temperature.

The PCF8591 slave address is:

Bit	7	6	5	4	3	2	1	0
Value	1	0	0	1	A2	A1	A0	R/W

The PCF8591 device initially requires a control byte to be written to the configuration register.

The control byte is as follows:

Bit	7	6	5	4	3	2	1	0
Value	0	A	0	0	0	B	C	D

When a single channel is to be read, A,B,C and D should be determined as follows:

A/D channel	A	B	C	D
Voltage	0	0	0	0
Current	0	0	0	1
Temperature	0	0	1	0

To read all channels with a single control byte, A and B have to be "1", C and D have to be "0". This control byte sets the device so that on each successive read the data from the next A/D is read. Thus, the first result from a sequence of reads should not be considered.

Note that on each read, a conversion is started for a particular channel and the result will be read from the previous channel.

7.4.4 A/D Scaling

The A/D readback has to be scaled to obtain a correct value for the voltage, current and the temperature. Note that the voltage reading is made inside the power supply unit before the "Oring" diode and is typically 0.5V higher than the actual output voltage.

The following scaling should be employed:

$$\text{VALUE} = \text{BYTE VALUE} \times \text{RESOLUTION}$$

Refer to the following table for the scaling of the A/D channels:

FPS1000-12/S	Range	Resolution	Accuracy
Voltage	0~15V	0.0586 V/Bit	+/-2% of full scale
Current	0~80A	0.312 A/Bit	+/-10% of full scale
Temperature	0~100°C	0.391°C/Bit	+/-3°C of full scale

FPS1000-24/S	Range	Resolution	Accuracy
Voltage	0~30V	0.1171V/Bit	+/-2% of full scale
Current	0~50A	0.1953A/Bit	+/-10% of full scale
Temperature	0~100°C	0.391°C/Bit	+/-3°C of full scale

FPS1000-32/S	Range	Resolution	Accuracy
Voltage	0~40V	0.1563V/Bit	+/-2% of full scale
Current	0~50A	0.1953A/Bit	+/-10% of full scale
Temperature	0~100°C	0.391°C/Bit	+/-3°C of full scale

FPS1000-48/S	Range	Resolution	Accuracy
Voltage	0~60V	0.2344V/Bit	+/-2% of full scale
Current	0~25A	0.0977A/Bit	+/-10% of full scale
Temperature	0~100°C	0.391°C/Bit	+/-3°C of full scale

The measurement range is from 0 to the maximum value listed in the range column. The resolution or scale of reading is linear over the entire range and provides a linear output on the A/D converter.

7.5 Measurements and calculation examples

7.5.1 Output voltage readback

The voltage before the "Oring" diode is measured and can be read from the A/D converter. This voltage is higher than the voltage at the output terminals by 0.5V typically.

Model: FPS 1000-48/S

1. Output voltage (at the output terminals): 48.0V
2. Voltage before the "Oring" diode: 48.0V+0.5V=48.5V
3. Hex readback: CE (1100 1110).
4. Convert the hex readback to decimal: 206
5. Calculate measured Vout: $V_{out}=206 \times 0.2344=48.286V$

7.5.2 Output current readback

The output current is sensed by an internal shunt and measured by an A/D converter. Refer to the following example for current readback calculation.

1. Actual output current: 21.0A
2. Hex readback: E0 (1110 0000).
3. Convert the hex readback to decimal: 224
4. Calculate measured Iout: $I_{out}=224 \times 0.0977=21.884A$.

7.5.3 Internal temperature measurement

The internal ambient temperature is measured to provide information of the safe operation of the power supply. The internal ambient temperature is usually higher than the power supply air intake temperature due to internal power dissipation. As the power dissipation varies with the load, the internal ambient temperature increases with the load. Refer to Fig 7-2 for typical internal temperature rise above the air intake temperature versus the load.

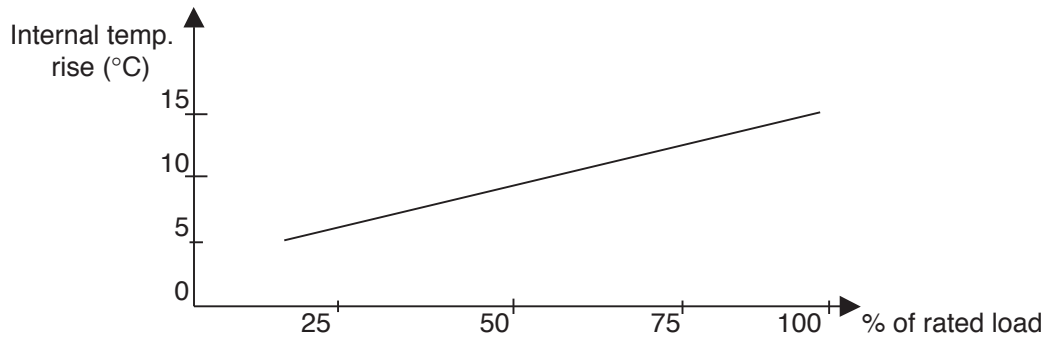

Fig 7-2: Internal temperature rise vs. load

Internal temperature calculation example:

1. Hex readback: 68 (0110 1000).
2. Convert hex readback to decimal: 104
3. Calculate the measured temperature:

$$\text{Temp} = 104 * 0.391 = 40.664^{\circ}\text{C}$$

7.6 Typical application diagram

A typical application is described in Fig 7-3.

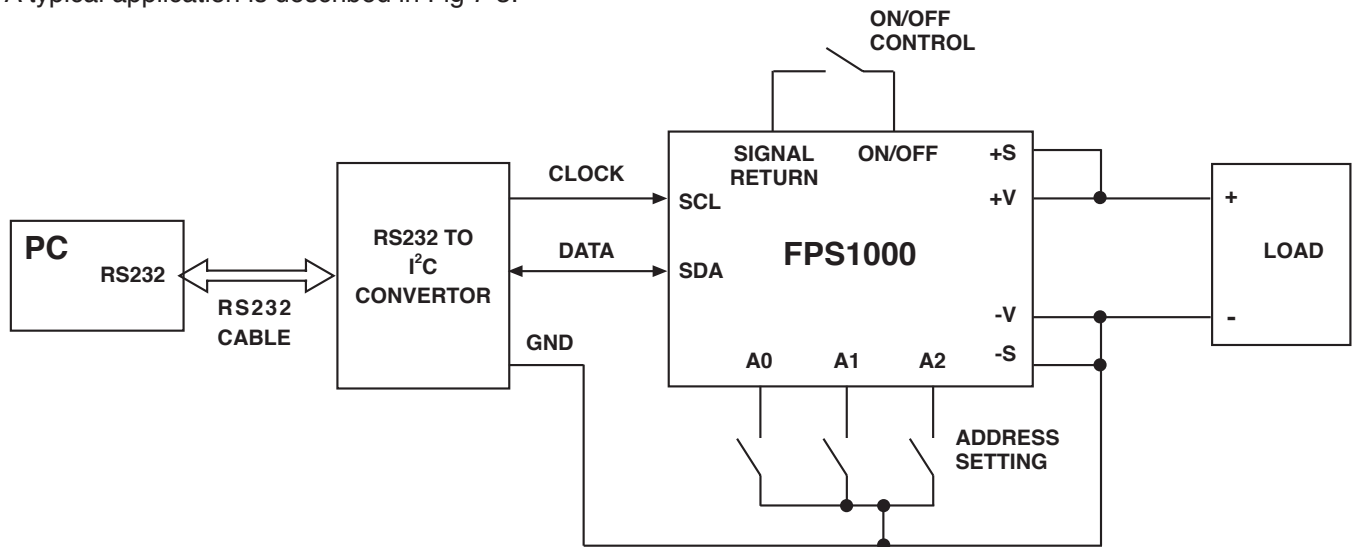

Fig 7-3: Typical application of I²C interface

CHAPTER 8 FPS1000 MAINTENANCE

8.1 Introduction

This chapter contains information about maintenance, calibration and troubleshooting of the FPS1000 power supply.

8.2 Units under warranty

Units requiring repairs during the warranty period should be returned to Densai-Lambda authorized service office. Unauthorized repairs performed by other than the authorized service facilities may void the warranty.

8.3 Periodic maintenance

No routine maintenance of the FPS1000 power supply is required except for periodic cleaning. To clean, disconnect the unit from the AC supply and allow 30sec. for discharging internal voltage. The FPS1000 should be cleaned using mild solution of detergent and water. The solution should be applied onto a soft cloth, and not directly to the surface of the unit. Do not use aromatic hydrocarbons or chlorinated solvents for cleaning. Use low pressure compressed air to blow dust from the unit.

8.4 Adjustments and Calibration

No internal adjustment or calibration are required. Units that are returned for repair will be calibrated at the service office. In any case, opening the cover is not allowed.

8.5 Fan life expectancy

The fan life has limitation depending mainly on the ambient temperature. Please refer to Fig 8-1 for the expected fan life vs. the ambient temperature. In case that the fan should be replaced, contact your nearest Densai-Lambda authorized service office.

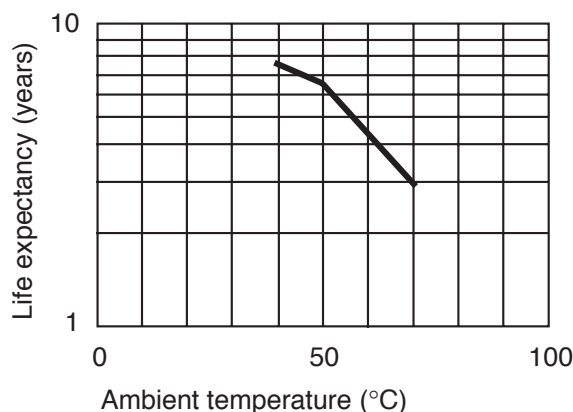

Fig 8-1: Expected fan life vs. ambient temperature

8.6 Before concluding that the unit is at fault:

Before concluding that the unit is at fault, make the following tests:

- * Check if the AC voltage is within the specification range.
- * Check if the input and output wiring is correct.
- * Check if the +S and -S wires are connected to the +Vout and -Vout (refer to sec. 4.11).
- * Check if the wires size is sufficient (refer to sec. 3.7.2).
- * Check if the output voltage control, V_Trim, is connected properly (refer to sec. 4.2).
- * Check if the On/Off control is connected properly (refer to sec. 4.10).
- * Check if the load current and power consumption are within the power supply specifications.
- * Audible noise can be heard during dynamic load operation.
- * Audible noise can be heard when the input voltage waveform is not sinusoidal.

8.7 Parts replacement and repair

As repairs are made only by the manufacturer or by its authorized service offices, no parts replacement information is given in this manual. In case of failure, unusual or erratic operation of the unit, contact your nearest Densai-Lambda sales and service office.

FPS-S1U 19" Rack Single Output

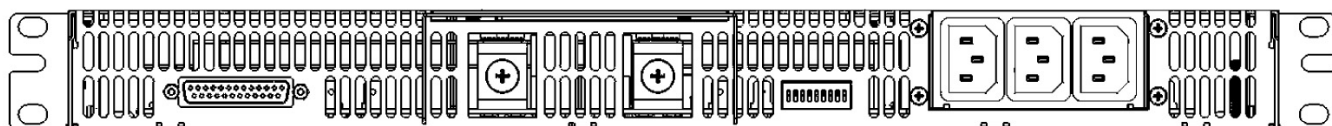
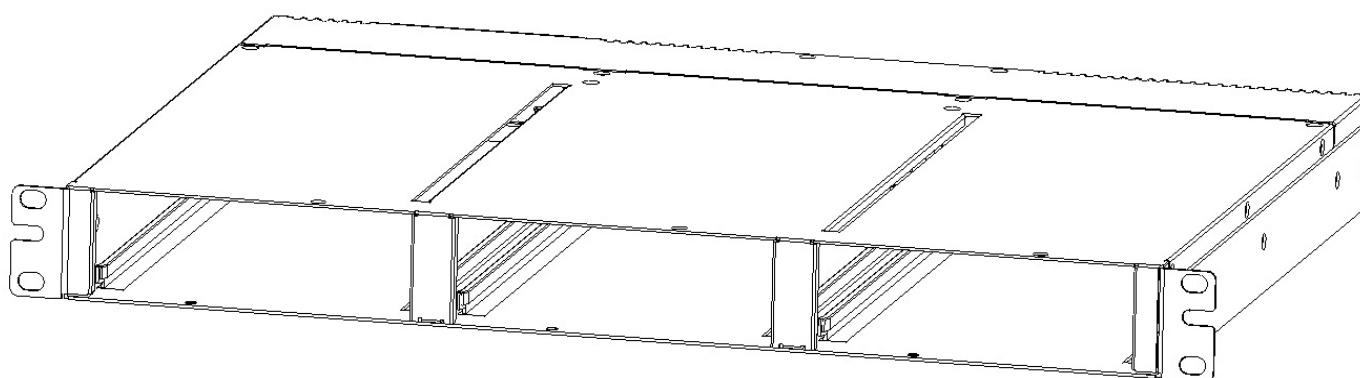

CHAPTER 9 FPS-S1U RACK SPECIFICATIONS

1	Number of power supply modules (*1)	---	Maximum 3 x FPS1000 modules of the same output voltage rating.
2	Maximum output power (*2)	W	3000
3	Input voltage / frequency range (*3)	---	85~265Vac continuous, 47~63Hz, Single phase
4	Maximum input current (at 100/200Vac)	A	12.0/6.0 for each FPS1000 unit installed
5	AC input connector	---	FPS-S1U :IEC inlet for each power supply module . FPS-S1U/P :None
6	Output terminals	---	Bus-bars.Refer to outline drawing.
7	Remote sensing (*4)	V	Possible.
8	Parallel operation	---	Possible. Up to 3 racks with max 8 FPS 1000 units of the same voltage and current rating.
9	Series operation (*5)	---	Possible. Up to 2 racks of the same voltage and current rating
10	Remote On/Off control	---	Separate control for each FPS 1000 unit , By electrical signal or dry contact ON: 0~0.6V or short. OFF: 2~15V or open.
11	DC_OK signal	---	Separate control for each FPS1000 unit, Open collector signal. On when Vout ≥80% +/-5%. Max.sink current: 10mA
12	AC fail signal	---	Separate control for each FPS1000 unit ,Open collector signal. Refer to Instruction Manual
13	Over Temperature alarm signal	---	Separate control for each FPS1000 unit ,Open collector signal. Refer to Instruction Manual
14	Vout voltage trimming	---	Possible, via separate control for each FPS1000 unit .Refer to Instruction Manual.
15	Auxiliary power supply	---	11.2~12.5VDC.Maximum output current:0.25A*Number of installed FPS1000 units.
16	Operating temperature	---	0~50°C: 100% load. Derate 2%/°C, 50°C to 60°C.
17	Storage temperature	---	-30~85°C
18	Operating humidity	---	10~90% RH, no condensation.
19	Storage humidity	---	10~90% RH, no condensation.
20	Vibration	---	Built to meet ETS 300 019
21	Shock	---	Built to meet ETS 300 019
22	Applicable safety standards	---	UL60950-1, EN60950-1
23	Withstand voltage	---	Input-Output: 3000Vrms, 1min. Input-Ground: 2000Vrms, 1min. Output-Ground: 500Vrms, 1min.
24	Insulation resistance	---	More than 100Mohm at 25°C and 70% RH. Output-Ground: 500Vdc
25	Weight (Typ)	Kg	3.7
26	Size (W*H*D)	---	440x44x351mm. Refer to Outline Drawing.
27	Warranty	Yr	Two Years

Notes:

- *1: The Output of all the FPS1000 modules are connected in parallel in the rack.
- *2: For input voltage lower than 100Vac, maximum output power derated by 10% of the power rating.
- *3: For cases where conformance to various safety standards (UL, EN etc.) is required, to be described as 100-240Vac (50/60Hz).
- *4: Remote sensing can compensate up to 1V drop on each load wire.
- *5: Not applicable for units with I²C bus option.

CHAPTER 10 FPS-S1U RACK INSTALLATION

10.1 GENERAL

This chapter contains instructions for initial inspection, preparation for use and repackaging for shipment. In some sections in this chapter, where the instructions for the FPS-S1U and the FPS1000 are identical, a reference to a section describing the FPS1000 will be given.

10.2 PREPARATION FOR USE

Table 10-1 below describes the basic setup procedure. Follow the instructions in Table 10-1 in the sequence given to prepare the FPS-S1U rack for use.

Step no	Item	Description	Reference
1	Inspection	Initial physical inspection of the power supply	Section 3.3
2	Installation	Installing the power supply.	Section 10.4
		Ensuring adequate ventilation.	Section 10.5
3	AC source	AC source requirements	Section 3.6
4	Load connection	Wire size selection.	Section 10.7

Table 10-1: Basic setup procedure

10.3 INITIAL INSPECTION

Refer to Sec. 3.3 for details.

10.4 FPS-S1U RACK MOUNTING

The FPS-S1U is designed to be mounted in a 19" rack. Use a support bars or surface to provide adequate support for the rear of the power supply. Secure the FPS-S1U to its location using the front panel using M6x12 screws via the mounting holes at its front side (Refer to the outline drawings in Chapter 11). Do not obstruct the air exhaust at the rear panel of the unit.

10.5 LOCATION MOUNTING AND COOLING

The FPS1000 units installed in the FPS-S1U rack are fan cooled. The air intake is at the front panel and the exhaust is at the rear panel. Upon installation allow cooling air to reach the front panel and allow minimum 50mm of unrestricted air space at the rear of the unit for the air exhaust.

10.6 AC SOURCE REQUIREMENTS

Refer to Sect 3.6 for details.

10.7 CONNECTING THE LOAD

WARNING

Turn off the AC input power before making or changing any rear panel connection. Ensure that all connections are securely tightened before applying power. There is a potential shock hazard when using a power supply with a rated output greater than 40V.

10.7.1 Load Wiring

.Refer to Sec. 3.7.1, 3.7.2 and 3.7.3 for details.

10.7.2 Inductive loads

To prevent damage to the power supply from inductive kickback, a diode should be connected across the output. The diode voltage and current rating should be greater than the power supply maximum output voltage and total current rating. Connect the cathode to the positive output and the anode to the negative output. Where positive load transients such as back EMF from a motor may occur, connect a surge suppressor across the output to protect the power supply. The breakdown voltage rating of the suppressor must be approximately 10% higher than the maximum output voltage of the power supply.

10.7.3 Making the load connections

 **WARNING**

Hazardous voltages may exist at the outputs and the load connections when using a power supply with a rated output greater than 40V. To protect personnel against accidental contact with hazardous voltages, ensure that the load and its connections has no accessible live parts. Ensure that the load wiring insulation rating is greater than or equal to the maximum output voltage of the power supply.

The load wires should be properly terminated with terminals securely attached. DO NOT use unterminated wires for load connection at the FPS-S1U.

10.7.4 Rear panel description

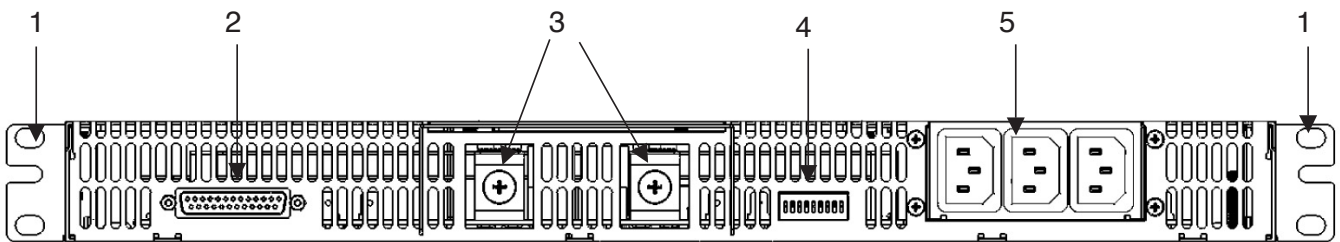

Fig. 10-1: FPS-S1U Rear panel

1. Mounting brackets. Use M6x12 screws to fix the FPS-S1U to the rack.
- 2: DB25 connector for control and monitoring signals.
- 3: Output voltage terminals. Use M6x16 screws and M6 lug to connect the load wire. The recommended tightening torque is 42~56Kgf.cm.
4. DIP switch for I²C option address setting. Refer to Chapter 14 for details.
5. IEC320 AC inlets, shown for FPS-S1U rack. For FPS-S1U/P, there are no IEC320 inlets on the rack.

10.7.5 Control and monitoring signals connector

Pin No	Function	Description
1	V_TRIM_B	Connection for output voltage trimming of FPS1000 unit "B". The voltage can be trimmed within its range specifications.
2	TEMP_ALARM_B	Open collector signal, referenced to pin 11 (Signal Return). On when the internal temperature of FPS1000 unit "B" is within safe limit, Off approx. 10°C below Thermal shut down. The maximum sink current is 10mA and the maximum external voltage is 15V.
3	DC_OK_B	Open collector signal, referenced to pin 11 (Signal Return). On when the output voltage of FPS1000 unit "B" is higher than $\geq 80\% \pm 5\%$. The maximum sink current: 10mA and the maximum external voltage is 15V.
4	TEMP_ALARM_A	Open collector signal, referenced to pin 11 (Signal Return). On when the internal temperature of FPS1000 unit "A" is within safe limit, Off approx. 10°C below Thermal shut down. The maximum sink current is 10mA and the maximum external voltage is 15V.
5	ON/OFF_A	Turns the output of FPS1000 unit "A" to On and Off by electrical signal or dry contact between pin 5 and pin 11 (Signal Return). 0~0.6V or Short: On, 2~15V or Open: Off. The maximum source current is 2.6mA.
6	DC_OK_A	Open collector signal, referenced to pin 11 (Signal Return). On when the output voltage of FPS1000 unit "A" is higher than $V_{out} \geq 80\% \pm 5\%$. The maximum sink current: 10mA and the maximum external voltage is 15V.
7	V_TRIM_A	Connection for output voltage trimming of FPS1000 unit "A". The voltage can be trimmed within its range specifications.
8	+12V_AUX	Auxiliary voltage output, 11.2~12.5V, referenced to pin 11 (Signal Return). The maximum load current is 0.25A. This output has built in Oring diode and is not controlled by the On/Off control.

10.7.5 Control and monitoring signals connector

9	CS	Current sharing signal. When FPS-S1U racks are connected in parallel, the CS pins of the units should be connected to allow current balance between units.
10	V_TRIM_C	Connection for output voltage trimming of FPS1000 unit "C". The voltage can be trimmed within its range specifications.
11	SIGNAL_RETURN	Return for the following control and supervisory signals: On/Off, DC_OK, Over_temperature Alarm, AC_Fail, Auxiliary 12V supply. The Signal return is isolated from the output terminals.
12	DC_OK_C	Open collector signal, referenced to pin 11 (Signal Return). On when the output voltage of FPS1000 unit "C" is higher than $\geq 80\% \pm 5\%$. The maximum sink current: 10mA and the maximum external voltage is 15V.
13	+SENSE	Positive sensing. The +Sense signal should be connected to the positive terminal of the load. The +Sense and -Sense leads should be twisted pair to minimize noise pick-up effect. The maximum load wires drop compensation is 1V/wire.
14	AC_FAIL_B	Open collector signal, referenced to pin 11 (Signal Return). On when the input voltage of FPS1000 unit "B" is $\geq 85V_{rms}$. The maximum sink current is 10mA, and the maximum external voltage is 15Vdc.
15	ON/OFF_B	Turns the output of FPS1000 unit "B" to On and Off by electrical signal or dry contact between pin 15 and pin 11 (Signal Return). 0~0.6V or Short: On, 2~15V or Open: Off. The maximum source current is 2.6mA.
16	AC_FAIL_A	Open collector signal, referenced to pin 11 (Signal Return). On when the input voltage of FPS1000 unit "A" is $\geq 85V_{rms}$. The maximum sink current is 10mA, and the maximum external voltage is 15Vdc.
17	NC	Not connected
18	NC	Not connected
19	NC	Not connected
20	SCL (I ² C)	Serial Clock used in the I ² C interface option. Refer to the I ² C interface description in the Chapter 7 in this Instruction Manual.
21	SDA (I ² C)	Serial Data used in the I ² C interface option. Refer to the I ² C interface description in the Chapter 7 in this Instruction Manual.
22	-SENSE	Negative sensing. The -Sense signal should be connected to the negative terminal of the load. The -Sense and +Sense leads should be twisted pair to minimize noise pick-up effect. The maximum load wires drop compensation is 1V/wire.
23	TEMP_ALARM_C	Open collector signal, referenced to pin 11 (Signal Return). On when the internal temperature of FPS1000 unit "C" is within safe limit, Off approx 10°C below Thermal shut down. The maximum sink current is 10mA and the maximum external voltage is 15V.
24	AC_FAIL_C	Open collector signal, referenced to pin 11 (Signal Return). On when the input voltage of FPS1000 unit "C" is $\geq 85V_{rms}$. The maximum sink current is 10mA, and the maximum external voltage is 15Vdc.
25	ON/OFF_C	Turns the output of FPS1000 unit "C" to On and Off by electrical signal or dry contact between pin 25 and pin 11 (Signal Return). 0~0.6V or Short: On, 2~15V or Open: Off. The maximum source current is 2.6mA.

10.7.6 Modules location

Up to three FPS1000 modules of the same output voltage rating can be plugged into an FPS-S1U rack. Refer to Fig 10-2 for the modules location.

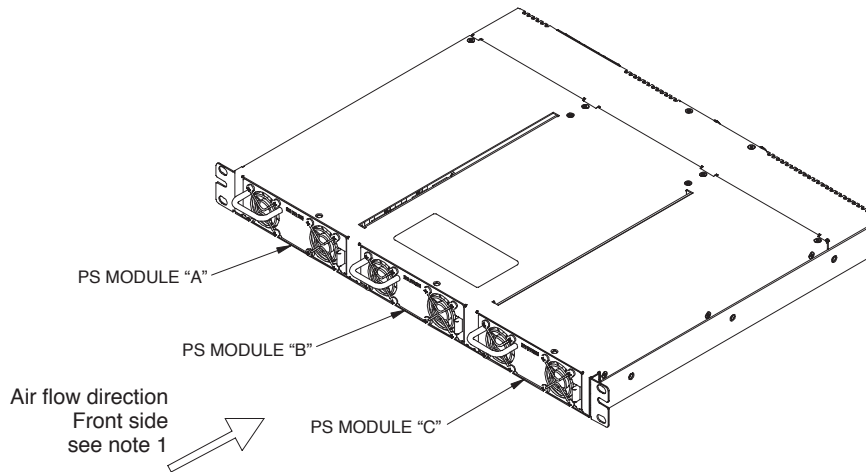

Fig 10-2: FPS1000 modules location

Note 1: Forced air cooling allow minimum 50mm of unrestricted air space at the rear of the unit. Do not obstruct air flow to the unit front panel.

10.7.7 Blank panels

Each FPS-S1U rack is supplied with two blank panels in the package. Use the blank panels to close the front panel opening in places where FPS1000 power supplies are not installed. Use M3x6 screws to fix the blank panel to the chassis. Refer to the outline drawings in chapter 11 for details.

10.7.8 Repackaging for shipment

Refer to Sec. 3.7.8 for details.

CHAPTER 11 FPS-S1U AND FPS-S1U/P OUTLINE DRAWINGS

11.1 FPS-S1U Outline Drawing

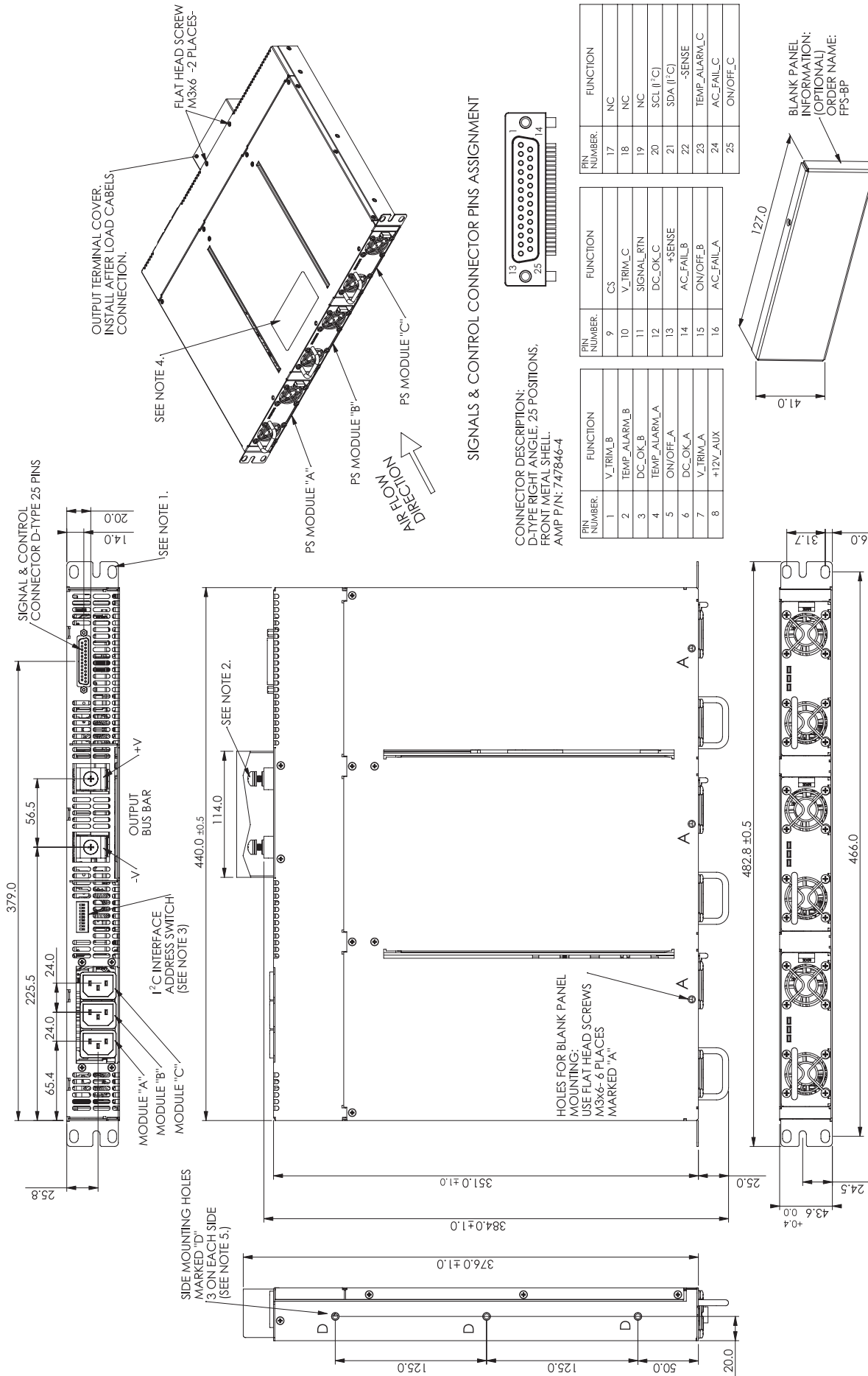

SIGNALS & CONTROL CONNECTOR PINS ASSIGNMENT

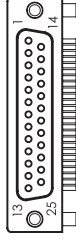

CONNECTOR DESCRIPTION:
 D-TYPE RIGHT ANGLE, 25 POSITIONS,
 FRONT METAL SHELL,
 AMP P/N: 747846-4

PIN NUMBER	FUNCTION	PIN NUMBER	FUNCTION	PIN NUMBER	FUNCTION
1	V_TRIM_B	9	CS	17	NC
2	TEMP_ALARM_B	10	V_TRIM_C	18	NC
3	DC_OK_B	11	SIGNAL_RTN	19	NC
4	TEMP_ALARM_A	12	DC_OK_C	20	SCL (I ² C)
5	ON/OFF_A	13	+SENSE	21	SDA (I ² C)
6	DC_OK_A	14	AC_FAIL_B	22	-SENSE
7	V_TRIM_A	15	ON/OFF_B	23	TEMP_ALARM_C
8	+12V_AUX	16	AC_FAIL_A	24	AC_FAIL_C
				25	ON/OFF_C

- NOTES**
1. MOUNTING HOLES FOR 19" RACK. USE M6x12 TO FIX THE UNIT TO A RACK.
 2. M6x16 SCREWS FOR LOAD WIRES FIXING. USE M6 LUG FOR THE LOAD WIRES. RECOMMENDED TIGHTENING TORQUE 42-56 kgf.cm
 3. REFER TO INSTRUCTION MANUAL FOR SETTING DETAILS.
 4. MODEL NAME, VOLTAGE AND CURRENT RATING AND SAFETY APPROVAL SYMBOLS WILL BE SHOWN HERE ACCORDING TO THE SPECIFICATIONS.
 5. MOUNTING HOLES M5 FOR MOUNTING BRACKETS. USE M5x8 SCREWS TO FIX THE BRACKETS TO THE CHASSIS. SCREWS MUST NOT PENETRATE THE CHASSIS MORE THAN 6 mm.
 6. THE FPS-S1U RACK IS SHOWN WITH 3 FPS 1000 UNITS INSTALLED.

11.2 FPS-S1U/P Outline Drawing

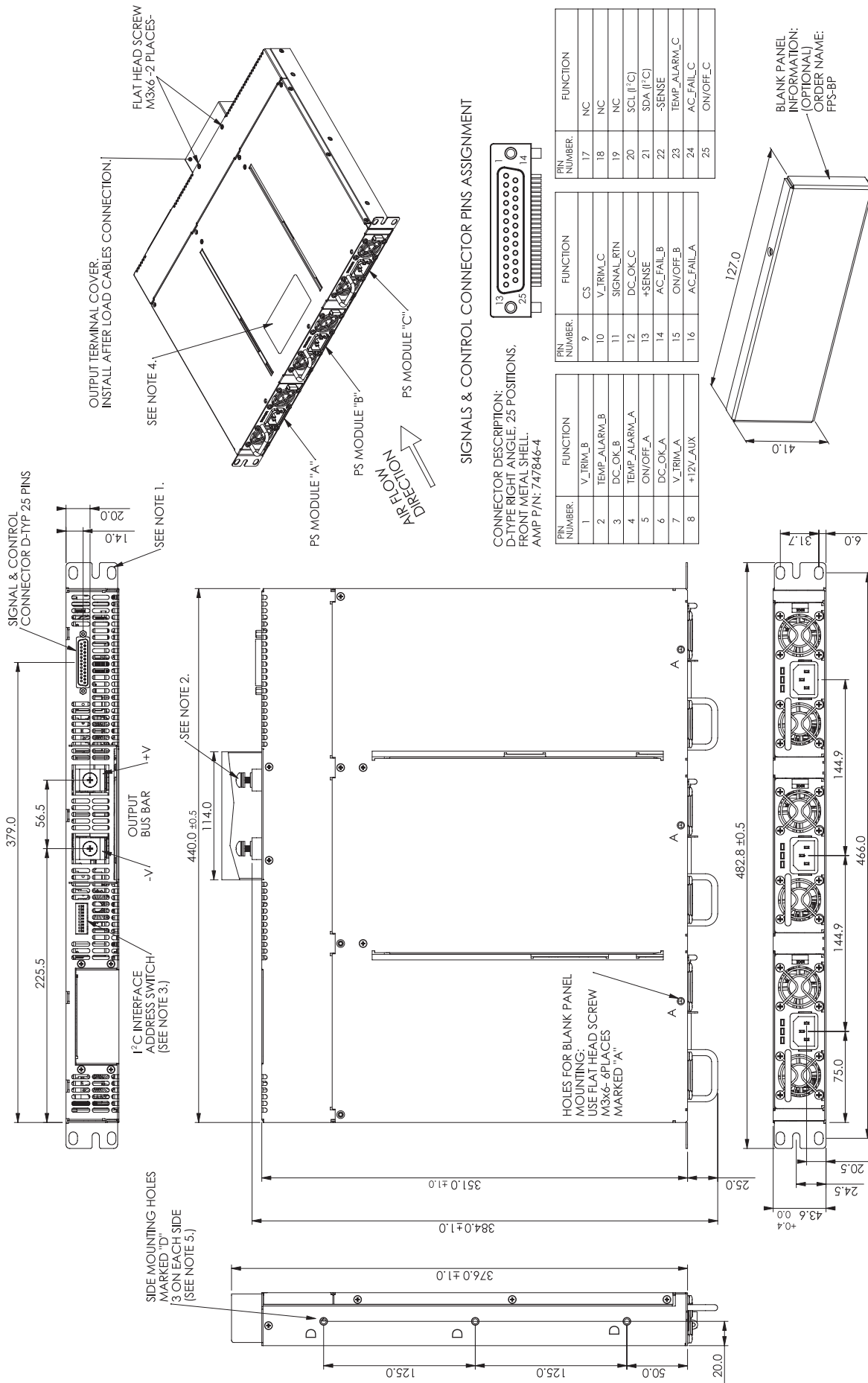

SIGNALS & CONTROL CONNECTOR PINS ASSIGNMENT

CONNECTOR DESCRIPTION:
D-TYPE RIGHT ANGLE, 25 POSITIONS,
FRONT METAL SHELL,
AMP P/N: 747846-4

PIN NUMBER	FUNCTION	PIN NUMBER	FUNCTION	PIN NUMBER	FUNCTION
1	V_TRIM_B	9	CS	17	NC
2	TEMP_ALARM_B	10	V_TRIM_C	18	NC
3	DC_OK_B	11	SIGNAL_RTN	19	NC
4	TEMP_ALARM_A	12	DC_OK_C	20	SCL (I ² C)
5	ON/OFF_A	13	+SENSE	21	SDA (I ² C)
6	DC_OK_A	14	AC_FAIL_B	22	-SENSE
7	V_TRIM_A	15	ON/OFF_B	23	TEMP_ALARM_C
8	+12V_AUX	16	AC_FAIL_A	24	AC_FAIL_C
				25	ON/OFF_C

BLANK PANEL INFORMATION (OPTIONAL) ORDER NAME: FPS-BP

- NOTES
1. MOUNTING HOLES FOR 1P" RACK. USE M6x12 TO FIX THE UNIT TO A RACK.
 2. M6x16 SCREWS FOR LOAD WIRES FIXING. USE M6 LUG FOR THE LOAD WIRES. RECOMMENDED TIGHTENING TORQUE 42-56 kgf.cm.
 3. REFER TO INSTRUCTION MANUAL FOR SETTING DETAILS.
 4. MODEL NAME, VOLTAGE AND CURRENT RATING AND SAFETY APPROVALS SYMBOLS WILL BE SHOWN HERE ACCORDING TO THE SPECIFICATIONS.
 5. MOUNTING HOLES M5 FOR MOUNTING BRACKETS. USE M5x8 SCREWS TO FIX THE BRACKETS TO THE CHASSIS. SCREWS MUST NOT PENETRATE THE CHASSIS MORE THAN 6 mm.
 6. THE FPS-S1U/P RACK IS SHOWN WITH 3 FPS1000/P UNITS INSTALLED.

CHAPTER 12 BASIC CONNECTIONS FOR OPERATION FPS-S1U RACK

12.1 Connecting single load, Local sensing

Local sensing is suitable for applications where load regulation is not critical. Fig 12-1 shows recommended load and sensing connections for applications with a single load.

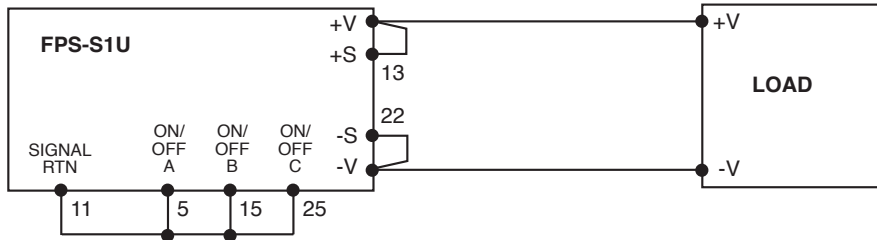

Fig 12-1: single load connection, local sensing

* In Local sense applications, the +/- sense have to be connected to the +/-V terminals of the FPS-S1U prior to operating the FPS1000 units plugged in.

12.2 Connecting Single Load, Remote Sensing

Remote sensing is used in cases where the load regulation is important at the load terminals. Use twisted or shielded wires to minimize noise pick-up. If shielded wires are used, the shield should be connected to the ground at one point, either the power supply side or the load. The optimal point for the shield ground should be determined by experimentation. Refer to the power supply specifications for the maximum voltage drop allowed at the load wires.

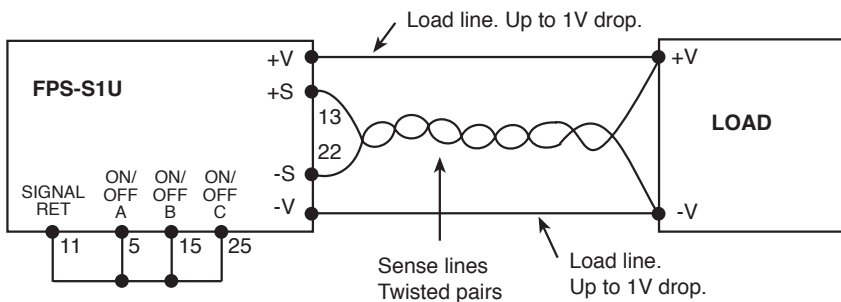

Fig 12-2: Remote sensing, single load.

12.3 Multiple loads connection

If remotely located output distribution terminals are used, the power supply output terminals should be connected to the distribution terminals by a pair of twisted or shielded wires. Each load should be separately connected to the remote distribution terminals (see Fig 12-3). If remote sensing is required, the sensing wires should be connected to the distribution terminals or at the most critical load.

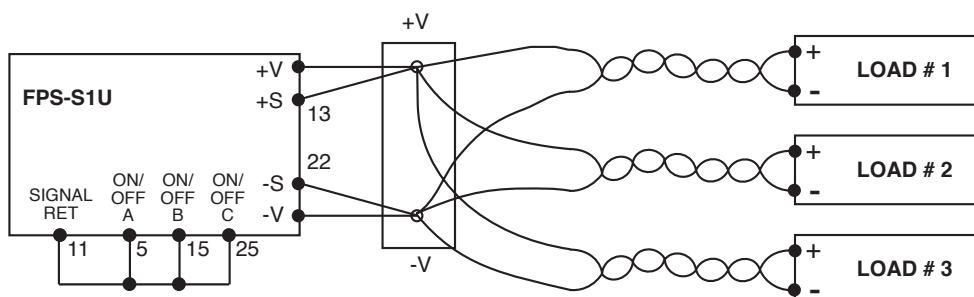

Fig 12-3: Multiple loads connection with distribution terminal

12.4 On/Off control

Fig 12-4 shows typical connection for individual On/Off control of each installed FPS1000 unit. The On/Off control signal is applied to the DB25 connector located at the rear panel (refer to sec. 10.7.5). When it is desired to control all the installed units simultaneously, it is possible to connect the On/Off control as shown in Fig 12-5.

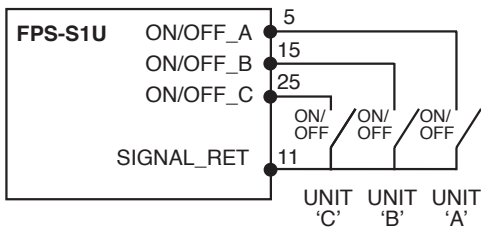

Fig 12-4: Individual On/Off control

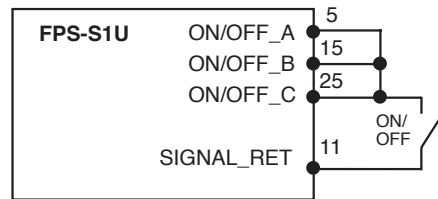

Fig 12-5: Single On/Off control

12.5 Output voltage trimming

Refer to Fig 12-6 for output voltage trimming typical application.

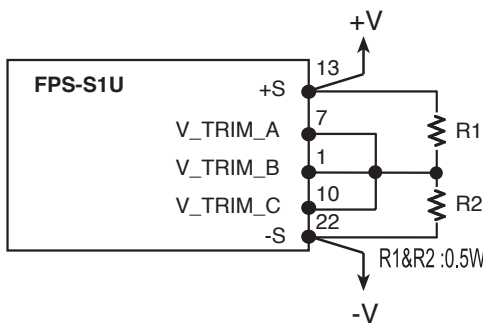

Fig 12-6: Output voltage trimming

FPS-S1U with FPS1000-12 installed:
 $R2 = 0.0324 * V_{out}^2 - 1.1298 * V_{out} + 9.9342$
 $R1(K\Omega) = 5(K\Omega) - R2(K\Omega)$

FPS-S1U with FPS1000-24 installed:
 $R2 = 0.0785 * V_{out}^2 - 5.819 * V_{out} + 105.132$
 $R1(K\Omega) = 20(K\Omega) - R2(K\Omega)$

FPS-S1U with FPS1000-32 installed:
 $R2 = 0.0463 * V_{out}^2 - 4.5805 * V_{out} + 109.49$
 $R1(K\Omega) = 20(K\Omega) - R2(K\Omega)$

FPS-S1U with FPS1000-48 installed:
 $R2 = 0.0497 * V_{out}^2 - 7.2795 * V_{out} + 259.04$
 $R1(K\Omega) = 50(K\Omega) - R2(K\Omega)$

12.6 Supervisory signals

Supervisory signals are accessible at the J1-DB25 female connector on the rear panel of the rack. Fig 12-7 shows a typical connection for FPS1000 unit "A" inside the rack. Units "B" and "C" connections - Refer to sec 10.7.5.

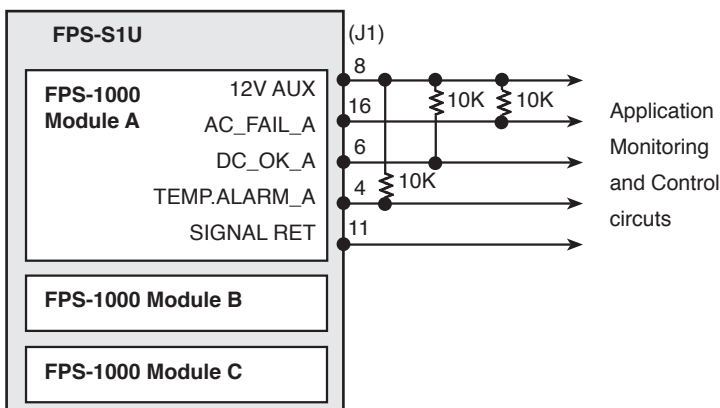

Note: AC_FAIL, DC_OK and TEMP.ALARM are open collector signals.

Fig 12-7: Supervisory signals

12.7 Grounding outputs

Either the positive or negative output terminals can be grounded. To avoid noise problems caused by common-mode current flowing from the load to ground, it is recommended to ground the output terminal as close as possible to the power supply's output. Always use two wires to connect the load to the power supply regardless of how the system is grounded.

CHAPTER 13 PARALLEL AND SERIES OPERATION

13.1 Parallel operation

Up to 3 FPS-S1U racks with up to 8 FPS1000 installed units of the same output voltage rating can be connected in parallel. The built-in Oring diodes on the main output and on the +12V auxiliary voltage in each FPS1000 unit allow N+1 operation. By connecting the CS signal between the paralleled units, automatic current balance is achieved, with +/-10% accuracy. For input voltages less than 100Vac, maximum output Power derated by 10% of the Power rating. Refer to Fig 13-1 for output Power derating in parallel operation.

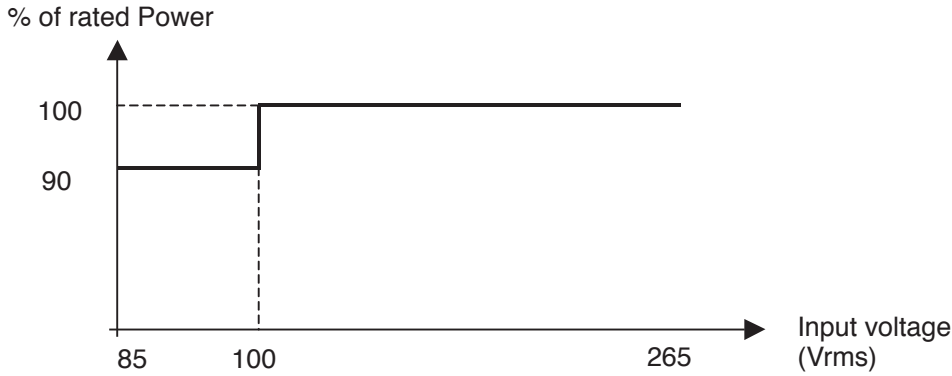

Fig 13-1: Output Power derating at parallel operation

13.1.1 Parallel operation with Remote sensing

Fig13-2 shows typical connection of parallel operation with Remote sensing. The CS signal wires should be as short as possible and with the same length.

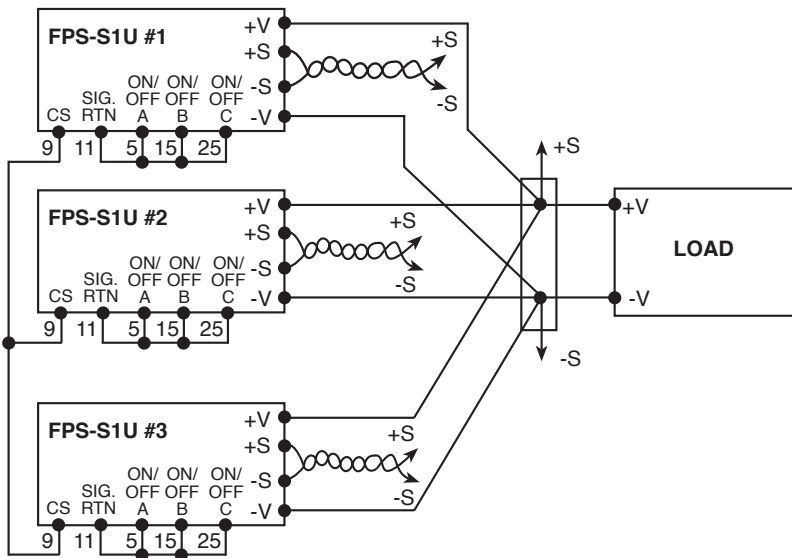
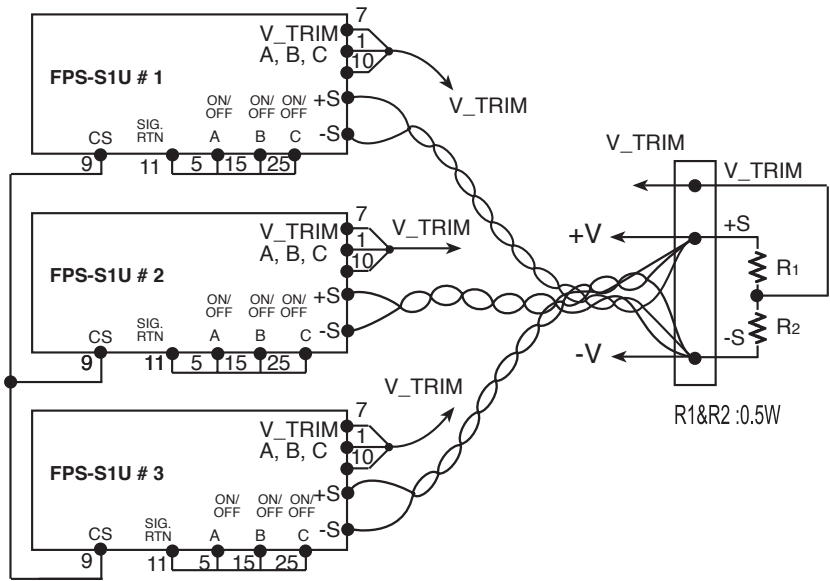

Fig 13-2: Parallel operation with Remote sensing

13.1.2 Output voltage trimming at parallel operation

The output voltage of the units connected in parallel can be made by a single trimmer or resistive divider.



FPS-S1U with FPS1000-12 installed:
 $R2=0.0324 \cdot V_{out}^2 - 1.1298 \cdot V_{out} + 9.9342$
 $R1(K\Omega)=5(K\Omega)-R2(K\Omega)$

FPS-S1U with FPS1000-24 installed:
 $R2=0.0785 \cdot V_{out}^2 - 5.819 \cdot V_{out} + 105.132$
 $R1(K\Omega)=20(K\Omega)-R2(K\Omega)$

FPS-S1U with FPS1000-32 installed:
 $R2=0.0463 \cdot V_{out}^2 - 4.5805 \cdot V_{out} + 109.49$
 $R1(K\Omega)=20(K\Omega)-R2(K\Omega)$

FPS-S1U with FPS1000-48 installed:
 $R2=0.0497 \cdot V_{out}^2 - 7.2795 \cdot V_{out} + 259.04$
 $R1(K\Omega)=50(K\Omega)-R2(K\Omega)$

Fig 13-3: Output voltage trimming at parallel operation

13.1.3 Signal Return bus at parallel operation

The Signal Return of each paralleled FPS-S1U rack can be connected together to form a common Signal Return bus. By this way, the control and monitoring signals of the paralleled racks can be connected to the same control and monitoring circuitry. The Signal Return bus can be connected to the -V or -S or +V or -S or float. Fig 13-4 shows typical connection of the Signal Return at parallel operation.

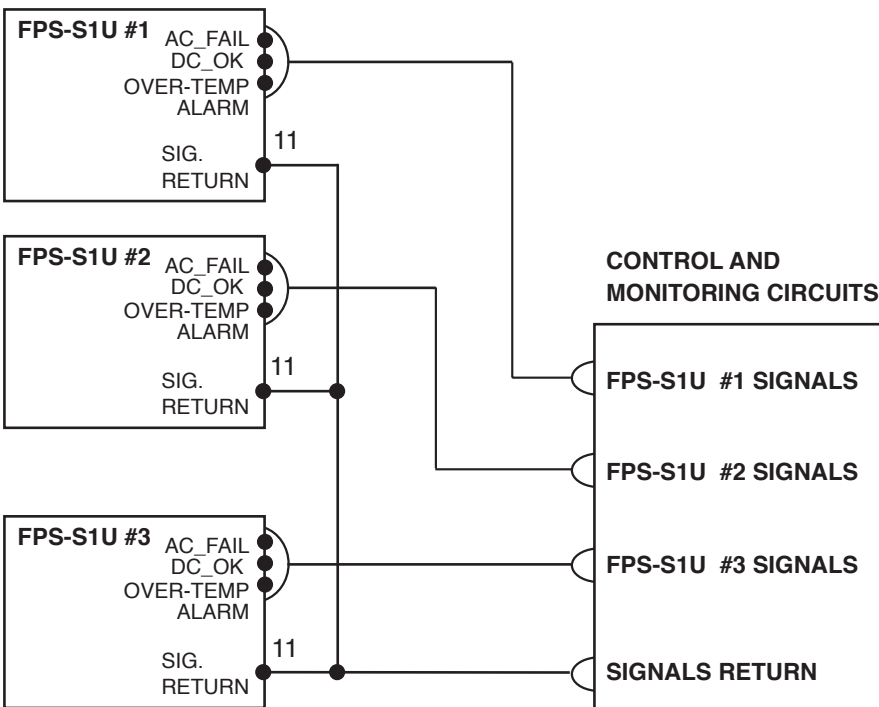

Fig 13-4: Signal Return connection at parallel operation

13.1.4 Remote On/Off control at parallel operation

The paralleled racks can be turned On or Off via a single On/Off control. Refer to Fig 13-5 for typical application. The Signal Return function of all the paralleled racks should be connected together to create a common Signal Return bus. The Signal Return bus may be connected to the -V or the +V potential or floated. In any case do not connect the Signal Return bus to different potentials.

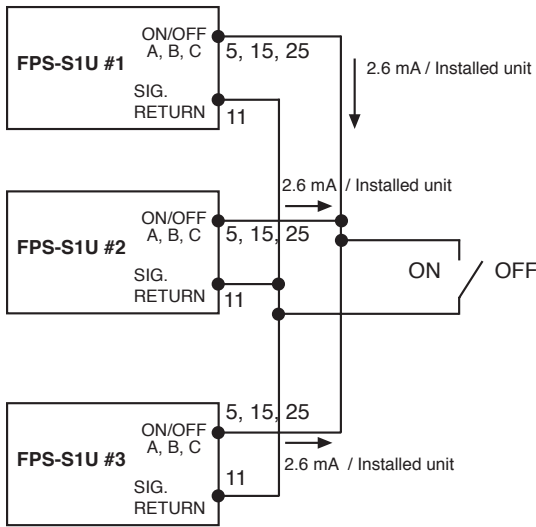

Fig 13-5: Remote On/Off control at parallel operation

13.2 Series operation

Two FPS-S1U racks with the same output voltage rating can be connected in series to increase the output voltage or to create a bipolar voltage source. It is recommended to connect diodes in parallel with each output to prevent reverse voltage in case of failure in one of the power supplies.

Each diode should be rated to at least the power supply rated output voltage and output current. Refer to Fig 13-6 and 13-7 for a typical series connection of power supplies.

CAUTION

Series operation is not applicable for units with I²C bus option.

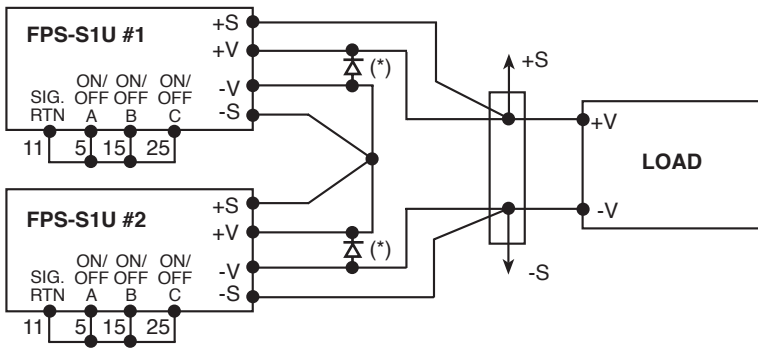

(*) Diodes are user supplied

Fig 13-6: Series connection for increased output voltage

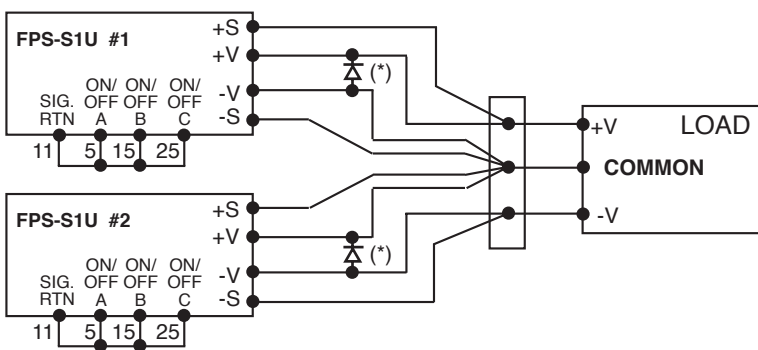

(*) Diodes are user supplied

Fig 13-7: Series connection for Bipolar output voltage

CHAPTER 14 FPS-S1U I²C BUS INTERFACE OPTION

14.1 Introduction

The FPS-S1U rack provides access to the I²C Bus interface in each installed FPS1000/S unit via the rear panel DB25 female connector located at the rear panel. The Clock is connected to pin 20 and the Data is connected to pin 21. The specifications of the I²C of the FPS1000/S power supplies are kept when they are installed in the FPS-S1U rack. Refer to Chapter 7 for the specifications and all operating details.

14.2 Addressing (A0, A1, A2).

The rear panel 9 positions DIP switch is used to select the I²C bus address for the individual FPS1000/S unit inside the rack. Each unit should have its own I²C address to communicate over the I²C bus.

Each address is made of three DIP switch positions, thus a single power supply in the FPS-S1U can be addressed with one of 8 different addresses.

Refer to Fig 14-1 for the description of the DIP switch setting. The DIP switch down position is logic level "1" and the up position is logic level "0".

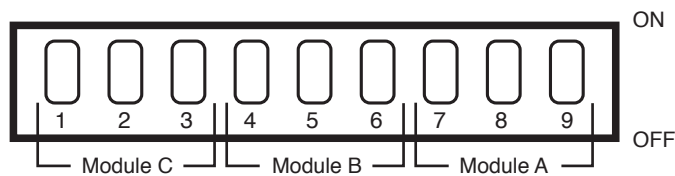

Fig 14-1: Address setting DIP switch (rear panel view)

CAUTION

The I²C bus address lines, serial clock and data are referenced to the -Sense potential. When using series connection of FPS-S1U racks, do not connect the I²C lines of the units together.

CHAPTER 15 FPS-S1U MAINTENANCE

15.1 Introduction

This chapter contains information about maintenance, calibration and troubleshooting of the FPS-S1U rack.

15.2 Units under warranty

Units requiring repairs during the warranty period should be returned to Densai-Lambda authorized service office. Unauthorized repairs performed by other than the authorized service facilities may void the warranty.

15.3 Periodic maintenance

No routine maintenance of the FPS-S1U rack is required except for periodic cleaning. To clean, disconnect the unit from the AC supply and allow 30sec. for discharging internal voltage. The FPS-S1U should be cleaned using mild solution of detergent and water. The solution should be applied onto a soft cloth, and not directly to the surface of the unit. Do not use aromatic hydrocarbons or chlorinated solvents for cleaning. Use low pressure compressed air to blow dust from the unit.

15.4 Adjustments and Calibration

No internal adjustment or calibration are required. Units that are returned for repair will be calibrated at the service office. In any case, opening the cover is not allowed.

15.5 Parts replacement and repair

As repairs are made only by the manufacturer or by its authorized service offices, no parts replacement information is given in this manual. In case of failure, unusual or erratic operation of the unit, contact your nearest Densai-Lambda sales and service office.

FPS-T1U 19" Rack Triple Output

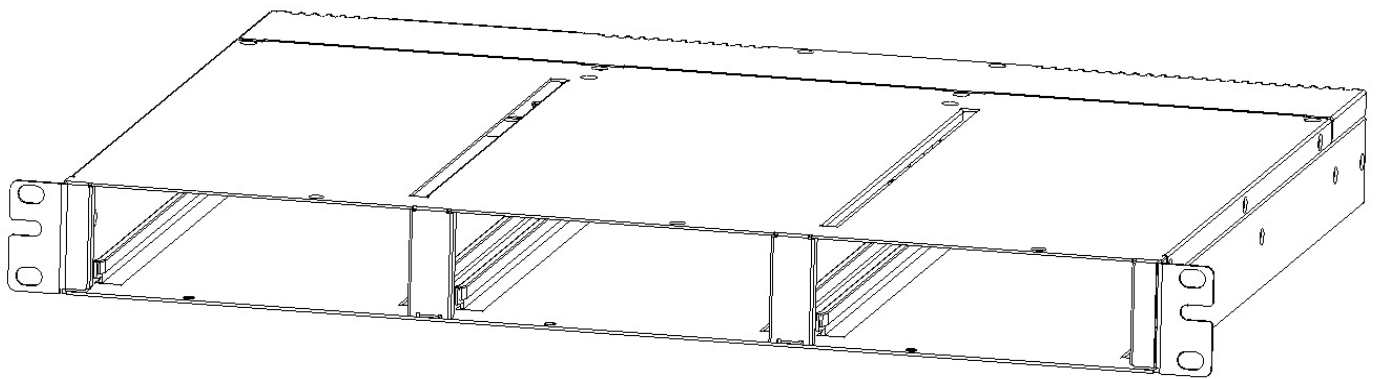

CHAPTER 16 FPS-T1U RACK SPECIFICATIONS

1	Number of power supply modules (*1)	---	Maximum 3 x FPS1000 modules.
2	Maximum output power (*2)	W	3000
3	Input voltage / frequency range (*3)	---	85~265Vac continuous, 47~63Hz, Single phase
4	Maximum input current (at 100/200Vac)	A	12.0/6.0 for each FPS1000 unit installed
5	AC input connector	---	FPS-T1U :IEC inlet for each power supply module . FPS-T1U/P :None
6	Output terminals	---	Bus-bars.Refer to outline drawing.
7	Remote sensing (*4)	V	Possible.
8	Parallel operation	---	Possible. Up to 3 racks with max 8FPS 1000 units of the same voltage and current rating.
9	Series operation (*5)	---	Possible. Up to 3x FPS1000 units of the same voltage and current rating
10	Remote On/Off control (*6)	---	Separate control for each FPS 1000 unit , By electrical signal or dry contact On/Off logic is user selectable. Refer to instruction manual.
11	DC_OK signal	---	Separate control for each FPS1000 unit, Open collector signal. On when Vout >80% +/-5%. Max.sink current: 10mA
12	AC fail signal	---	Separate control for each FPS1000 unit ,Open collector signal. Refer to Instruction Manual
13	Over Temperature alarm signal	---	Separate control for each FPS1000 unit ,Open collector signal. Refer to Instruction Manual
14	Vout voltage trimming	---	Possible, via separate control for each FPS1000 unit .Refer to Instruction Manual.
15	Auxiliary power supply	---	11.2~12.5VDC.Maximum output current:0.25A, for each FPS1000 unit.
16	Operating temperature	---	0~50°C: 100% load. Derate 2%/°C, 50°C to 60°C.
17	Storage temperature	---	-30~85°C
18	Operating humidity	---	10~90% RH, no condensation.
19	Storage humidity	---	10~95% RH, no condensation.
20	Vibration	---	Built to meet ETS 300 019
21	Shock	---	Built to meet ETS 300 019
22	Applicable safety standards	---	UL60950-1, EN60950-1
23	Withstand voltage	---	Input-Output: 3000Vrms, 1min. Input-Ground: 2000Vrms, 1min. Output-Ground: 1414Vdc, 1min.
24	Insulation resistance	---	More than 100Mohm at 25°C and 70% RH. Output-Ground: 500Vdc
25	Weight (Typ)	Kg	3.7
26	Size (W*H*D)	---	440x44x351mm. Refer to Outline Drawing.
27	Warranty	Yr	Two Years

Notes:

- *1: The Output of all the FPS1000 modules are floating in the rack.
- *2: For input voltage lower than 100Vac, maximum output power derated by 10% of the power rating.
- *3: For cases where conformance to various safety standards (UL, EN etc.) is required, to be described as 100-240Vac (50/60Hz).
- *4: Remote sensing can compensate up to 1V drop on each load wire.
- *5: Not applicable for units with I²C bus option.
- *6: Factory default: ON/OFF_1 P.S. is On when AC is applied.

CHAPTER 17 FPS-T1U RACK INSTALLATION

17.1 GENERAL

This chapter contains instructions for initial inspection, preparation for use and repackaging for shipment. In some sections in this chapter, where the instructions for the FPS-T1U and the FPS1000 are identical, a reference to a section describing the FPS1000 will be given.

17.2 PREPARATION FOR USE

Table 10-1 below describes the basic setup procedure. Follow the instructions in Table 17-1 in the sequence given to prepare the FPS-T1U rack for use.

Step no	Item	Description	Reference
1	Inspection	Initial physical inspection of the power supply	Section 3.3
2	Installation	Installing the power supply.	Section 10.4
		Ensuring adequate ventilation.	Section 10.5
3	AC source	AC source requirements	Section 3.6
4	Load connection	Wire size selection.	Section 10.7

Table 17-1: Basic setup procedure

17.3 INITIAL INSPECTION

Refer to Sec. 3.3 for details.

17.4 FPS-T1U RACK MOUNTING

The FPS-T1U is designed to be mounted in a 19" rack. Use a support bars or surface to provide adequate support for the rear of the power supply. Secure the FPS-T1U to its location using the front panel using M6x12 screws via the mounting holes at its front side (Refer to the outline drawings in Chapter 18). Do not obstruct the air exhaust at the rear panel of the unit.

17.5 LOCATION MOUNTING AND COOLING

The FPS1000 units installed in the FPS-T1U rack are fan cooled. The air intake is at the front panel and the exhaust is at the rear panel. Upon installation allow cooling air to reach the front panel and allow minimum 50mm of unrestricted air space at the rear of the unit for the air exhaust.

17.6 AC SOURCE REQUIREMENTS

Refer to Sect 3.6 for details.

17.7 CONNECTING THE LOAD

WARNING

Turn off the AC input power before making or changing any rear panel connection. Ensure that all connections are securely tightened before applying power. There is a potential shock hazard when using a power supply with a rated output greater than 40V.

17.7.1 Load Wiring

Refer to Sec. 3.7.1, 3.7.2 and 3.7.3 for details.

17.7.2 Inductive loads

To prevent damage to the power supply from inductive kickback, a diode should be connected across the output. The diode voltage and current rating should be greater than the power supply maximum output voltage and total current rating. Connect the cathode to the positive output and the anode to the negative output. Where positive load transients such as back EMF from a motor may occur, connect a surge suppressor across the output to protect the power supply. The breakdown voltage rating of the suppressor must be approximately 10% higher than the maximum output voltage of the power supply.

17.7.3 Making the load connections



WARNING

Hazardous voltages may exist at the outputs and the load connections when using a power supply with a rated output greater than 40V. To protect personnel against accidental contact with hazardous voltages, ensure that the load and its connections has no accessible live parts. Ensure that the load wiring insulation rating is greater than or equal to the maximum output voltage of the power supply.

The load wires should be properly terminated with terminals securely attached. DO NOT use unterminated wires for load connection at the FPS-T1U.

17.7.4 Rear panel description

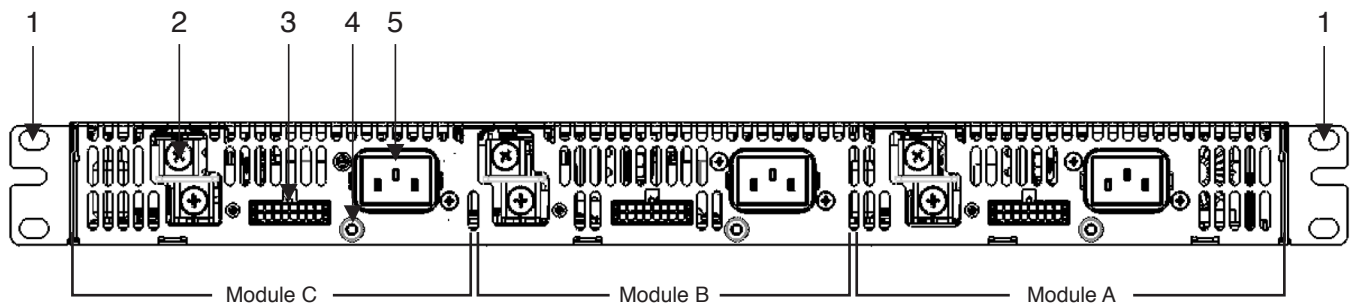

Fig. 17-1: FPS-T1U Rear panel

1. Mounting brackets. Use M6x12 screws to fix the FPS-T1U to the rack.
2. Output voltage terminals rugged busbars. Use M5x12 screws for load wires recommended Tightening torque 24~31 Kgf.cm.
3. Micro-Fit 3.0™ Dual Row Right Angle 16pins (Molex) connector for control and monitoring signals.
4. Ground stud M4 (three place).
5. IEC320 AC inlet ,shown for FPS-T1U. For FPS-T1U/P there are no IEC320 inlets on the rack.

17.7.5 Rear Panel In/Out Connector Pins Function Description J1(A), J2(B), J3(C)

Pin No	Function	Description
1	SDA (I ² C)	Serial Data used in the I ² C interface option. Refer to the I ² C interface description in the FPS1000 Instruction Manual.
2	SCL (I ² C)	Serial Clock used in the I ² C interface option. Refer to the I ² C interface description in the FPS1000 Instruction Manual.
3	SIGNAL_RETURN	Return for the following control and supervisory signals: On/Off, DC_OK, Over_temperature Alarm, AC_Fail, Auxiliary 12V supply. The Signal return is isolated from the output terminals.
4	ON/OFF_2 (*1)	On/Off control. To use this input, pin#12 and pin#13 must be shorted together. Short between On/Off_2 to pin#3: Off. Open On/Off_2: On. The maximum source current is 1.2mA
5	DC_OK	Open collector signal, referenced to pin 3 (Signal Return). On when the output voltage of FPS1000 unit is higher than Vout ≥ 80% +/-5%. The maximum sink current: 10mA and the maximum external voltage is 15V.
6	V_TRIM	Connection for output voltage trimming of FPS1000 unit. The voltage can be trimmed within its range specifications.
7	-SENSE	Negative sensing. The -Sense signal should be connected to the negative terminal of the load. The -Sense and +Sense leads should be twisted pair to minimize noise pick-up effect. The maximum load wires drop compensation is 1V/wire.
8	+SENSE	Positive sensing. The +Sense signal should be connected to the positive terminal of the load. The +Sense and -Sense leads should be twisted pair to minimize noise pick-up effect. The maximum load wires drop compensation is 1V/wire.
9	+12V_AUX	Auxiliary voltage output, 11.2~12.5V, referenced to pin 3 (Signal Return). The maximum load current is 0.25A. This output is not controlled by the On/Off control.
10	CS	Current sharing signal. When FPS1000 units are connected in parallel, the CS pins of the units should be connected to allow current balance between units.
11	AC_FAIL	Open collector signal, referenced to pin 3 (Signal Return). On when the input voltage of FPS1000 unit is ≥85Vrms. The maximum sink current is 10mA, and the maximum external voltage is 15Vdc.
12	ON/OFF_1 (*1)	Turns the output of FPS1000 unit to On and Off by electrical signal or dry contact between pin 12 and pin 3 (Signal Return). 0~0.6V or Short: On, 2~15V or Open: Off. The maximum sink current is 2.6 mA (when using pin#12, it should be disconnected from pin#13).
13	ON/OFF LOGIC SELECT	Input used to select the On/Off control logic. Short this input to pin#12 when using On/Off_2 as On/Off control. Leave this input open when using On/Off_1 as On/Off control.
14	TEMP_ALARM	Open collector signal, referenced to pin 3 (Signal Return). On when the internal temperature of FPS1000 unit is within safe limit, Off approx. 10°C below Thermal shut down. The maximum sink current is 10mA and the maximum external voltage is 15V.
15	- LOCAL SENSE	When working in local sense mode, connect -Local Sense to -Sense (pin#7). When working in Remote sense mode, this input should be open.
16	+ LOCAL SENSE	When working in local sense mode, connect +Local Sense to +Sense (pin#8). When working in Remote sense mode, this input should be open.

Rear In/Out connector pins function description (J1), (J2), (J3)

Note:

*1: On/Off_1 and On/Off_2 are reversed logic inputs.

CONNECTOR PINOUT (REAR PANEL VIEW)

J1(A), J2(B), J3(C) CONECTOR DESCRIPTION

MALE HEADER: P/N-43045-1600 (MOLEX)
 FEMALE HOUSING (PLUG): P/N-43025-1600 (MOLEX)
 FEMALE TERMINAL: P/N-43030 (MOLEX)

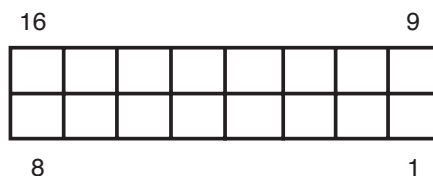

17.7.6 Modules location

Up to three FPS1000 modules can be plugged into an FPS-T1U rack. Refer to Fig 17-2 for the modules location.

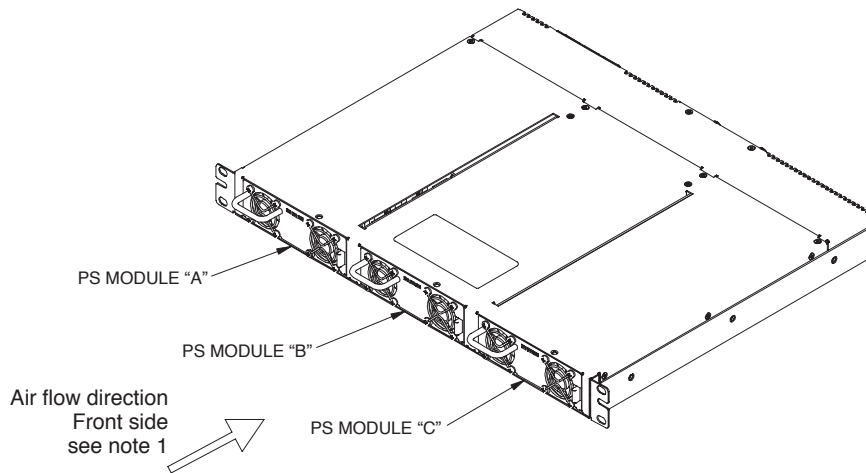

Fig 17-2: FPS1000 modules location

Note 1: Forced air cooling allow minimum 50mm of unrestricted air space at the rear of the unit. Do not obstruct air flow to the unit front panel.

17.7.7 Blank panels

Each FPS-T1U rack is supplied with two blank panels in the package. Use the blank panels to close the front panel opening in places where FPS1000 power supplies are not installed. Use M3x6 screws to fix the blank panel to the chassis. Refer to the outline drawings in chapter 18 for details.

17.7.8 Repackaging for shipment

Refer to Sec. 3.7.8 for details.

CHAPTER 18 FPS-T1U AND FPS-T1U/P OUTLINE DRAWINGS

18.1 FPS-T1U Outline Drawing

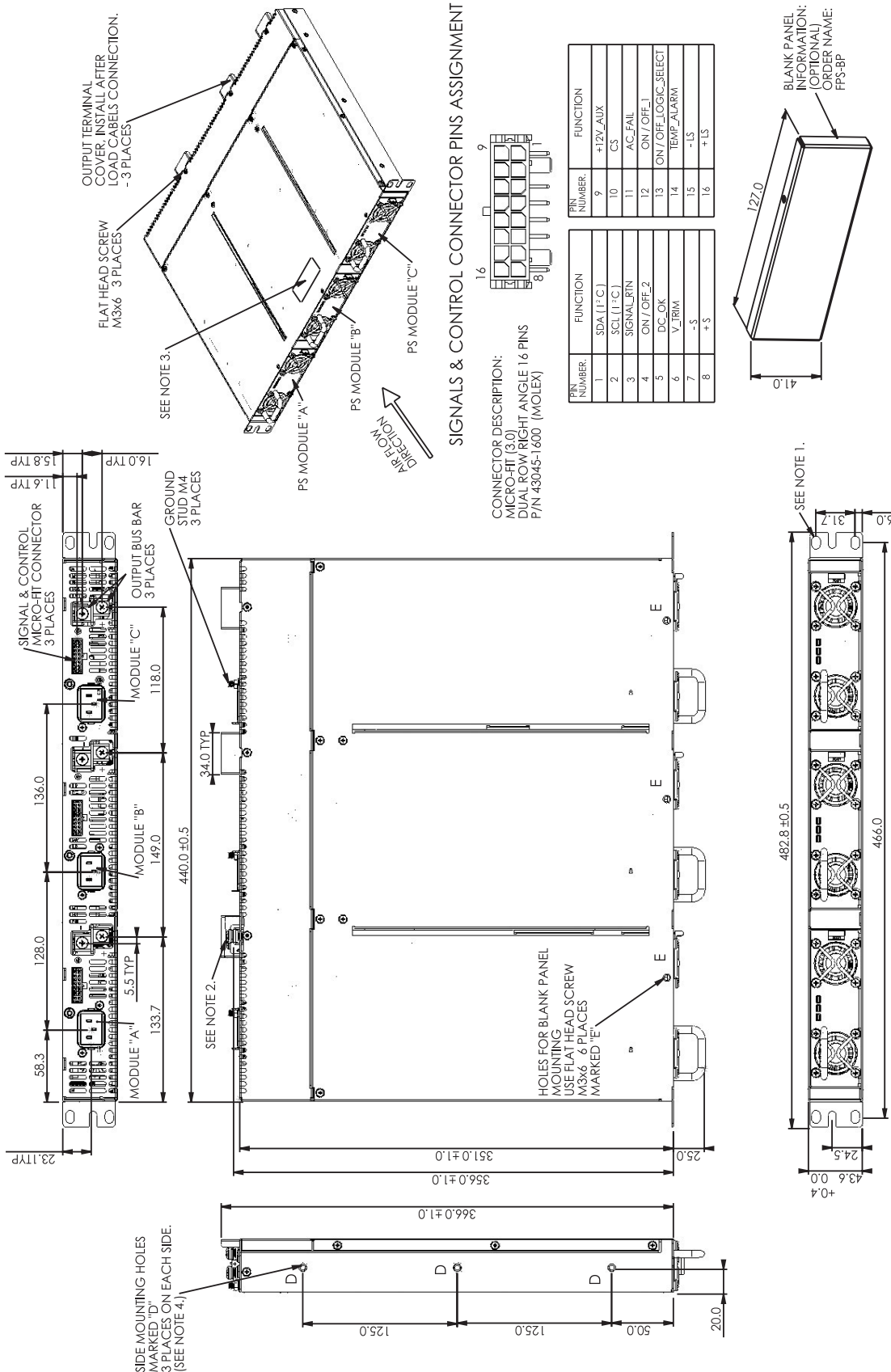

- NOTES
1. MOUNTING HOLES FOR 19" RACK. USE M6x12 TO FIX THE UNIT TO A RACK.
 2. M5x12 SCREWS FOR LOAD WIRES FIXING. USE M5 LUG FOR THE LOAD WIRES. RECOMMENDED TIGHTENING TORQUE 24-31 Kgf.cm
 3. MODEL NAME, VOLTAGE AND CURRENT RATING AND SAFETY APPROVALS SYMBOLS WILL BE SHOWN HERE ACCORDING TO THE SPECIFICATIONS.
 4. MOUNTING HOLES M5 FOR MOUNTING BRACKETS. USE M5x8 SCREWS TO FIX THE BRACKETS TO THE CHASSIS. SCREWS MUST NOT PENETRATE THE CHASSIS MORE THAN 6 mm.
 5. THE FPS-T1U RACK IS SHOWN WITH 3 FPS1000 UNITS INSTALLED.

18.2 FPS-T1U/P Outline Drawing

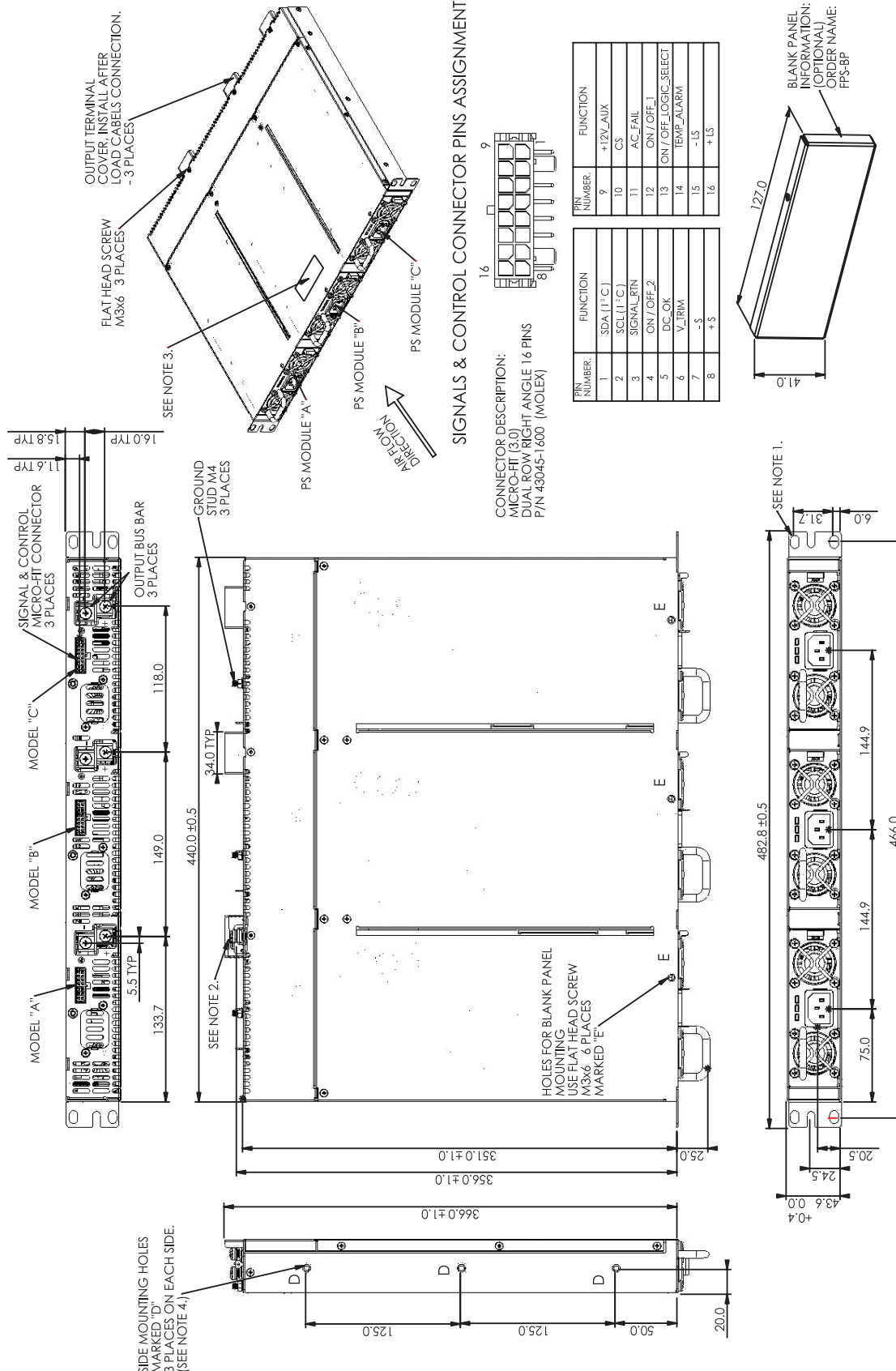

SIGNALS & CONTROL CONNECTOR PINS ASSIGNMENT

CONNECTOR DESCRIPTION:
MICRO-FIT (3.0)
DUAL ROW RIGHT ANGLE 16 PINS
P/N 43045-1600 (MOLEX)

PIN NUMBER	FUNCTION	PIN NUMBER	FUNCTION
1	SDA (I ² C)	9	+12V_AUX
2	SCL (I ² C)	10	CS
3	SIGNAL RTN	11	AC FAIL
4	ON / OFF-2	12	ON / OFF-1
5	DC_OK	13	ON / OFF_LOGIC_SELECT
6	V_TRIM	14	TEMP_ALARM
7	-S	15	-LS
8	+S	16	+LS

- NOTES**
1. MOUNTING HOLES FOR 19" RACK. USE M6x12 TO FIX THE UNIT TO A RACK.
 2. M5x12 SCREWS FOR LOAD WIRES FIXING. USE M5 LUG FOR THE LOAD WIRES. RECOMMENDED TIGHTENING TORQUE 24-31 Kgf.cm
 3. MODEL NAME, VOLTAGE AND CURRENT RATING AND SAFETY APPROVAL SYMBOLS WILL BE SHOWN HERE ACCORDING TO THE SPECIFICATIONS.
 4. MOUNTING HOLES M5 FOR MOUNTING BRACKETS. USE M5x8 SCREWS TO FIX THE BRACKETS TO THE CHASSIS. SCREWS MUST NOT PENETRATE THE CHASSIS MORE THAN 6 mm.
 5. THE FPS-T1U RACK IS SHOWN WITH 3 FPS1000 UNITS INSTALLED.

CHAPTER 19 BASIC CONNECTIONS FOR OPERATION FPS-T1U RACK

19.1 Connecting Single Load, Remote Sensing

Remote sensing is used in cases where the load regulation is important at the load terminals. Use twisted or shielded wires to minimize noise pick-up. If shielded wires are used, the shield should be connected to the ground at one point, either the power supply side or the load. The optimal point for the shield ground should be determined by experimentation. Refer to the power supply specifications for the maximum voltage drop allowed at the load wires.

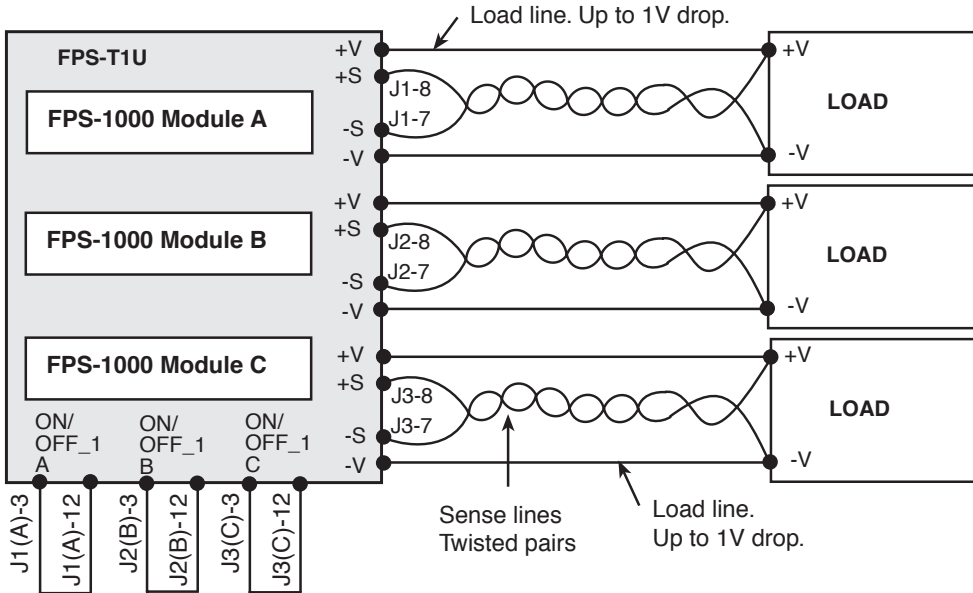

Fig 19-1: Remote sensing, three load.

* In Local sense applications, the +/- sense have to be connected to the +/-Local Sense terminals of the FPS-T1U prior to operating the FPS1000 units plugged in.

19.2 On/Off control

Fig 19-2 and Fig 19.3 shows typical connection for individual On/Off control of each installed FPS1000 unit.

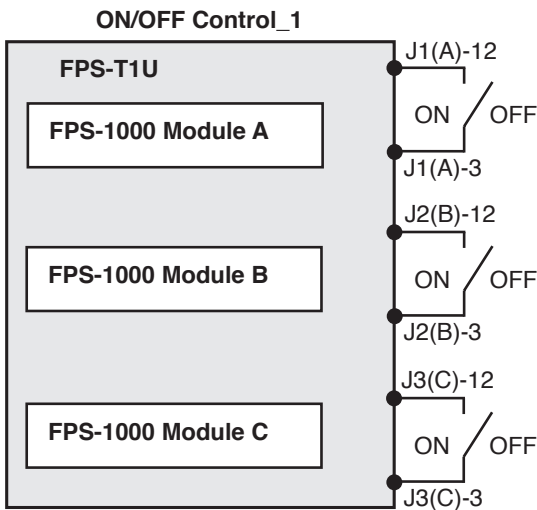

Fig 19-2

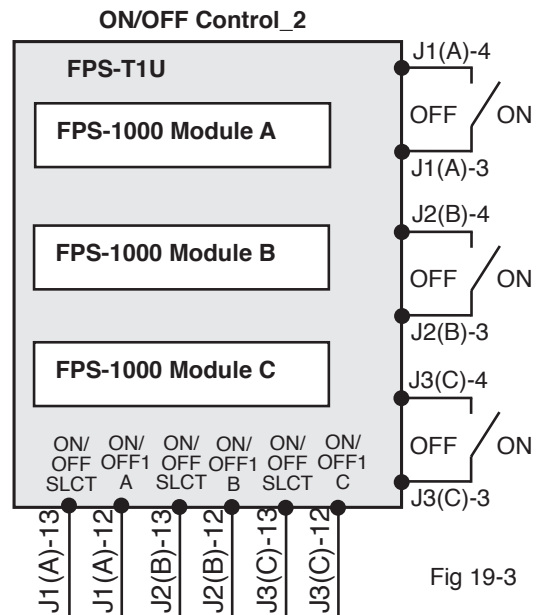

Fig 19-3

Connection for negative logic:
 Closed: On Open: Off
 Factory default: ON/OFF Control_1

Connection for positive logic:
 Closed: Off Open: On

19.3 Output Voltage Trimming

Fig 19-4 shows typical output voltage trimming connection for FPS1000 unit 'A' inside the rack
Units 'B' and 'C' connections - Refer to 17.7.5

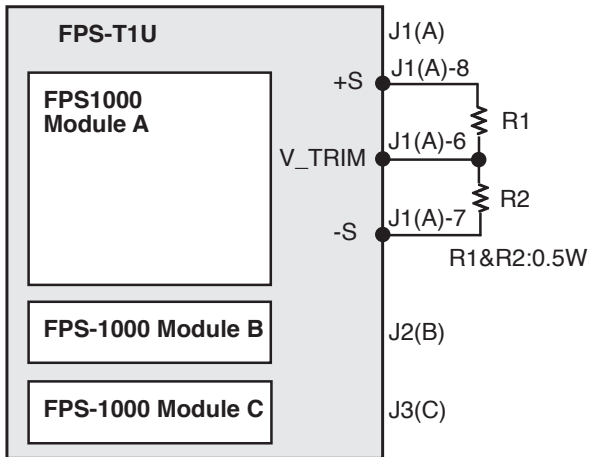

FPS1000-12:
 $R2 = 0.0324 * V_{out}^2 - 1.1298 * V_{out} + 9.9342$
 $R1(K\Omega) = 5(K\Omega) - R2(K\Omega)$

FPS1000-24:
 $R2 = 0.0785 * V_{out}^2 - 5.819 * V_{out} + 105.132$
 $R1(K\Omega) = 20(K\Omega) - R2(K\Omega)$

FPS1000-32:
 $R2 = 0.0463 * V_{out}^2 - 4.5805 * V_{out} + 109.49$
 $R1(K\Omega) = 20(K\Omega) - R2(K\Omega)$

FPS1000-48:
 $R2 = 0.0497 * V_{out}^2 - 7.2795 * V_{out} + 259.04$
 $R1(K\Omega) = 50(K\Omega) - R2(K\Omega)$

Fig 19-4 Output Voltage Trimming

19.4 Supervisory Signals

Signals are accessible at the J1(A), J2(B), J3(C) connectors on the rear panel of the rack
Fig 19-5 shows typical connection for FPS1000 unit 'A' inside the rack
Units 'B' and 'C' connections - Refer to 17.7.5

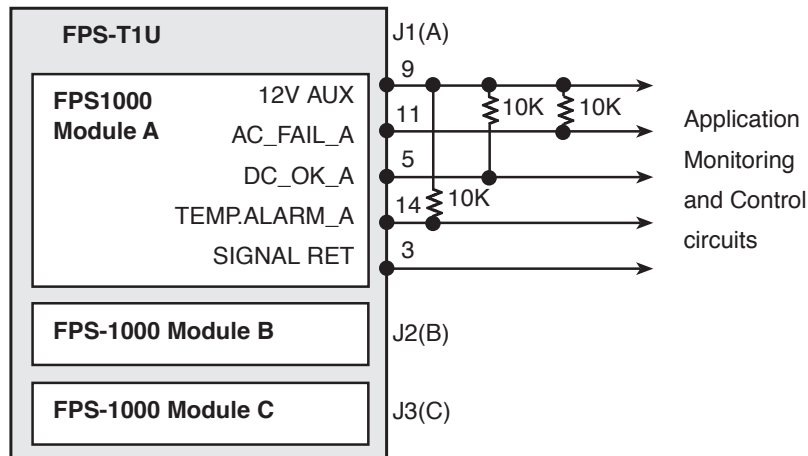

Fig 19-5 Supervisory Signals

Note: AC_FAIL, DC_OK and TEMP.ALARM are open collector signals

19.5 Grounding outputs

Either the positive or negative output terminals can be grounded. To avoid noise problems caused by common-mode current flowing from the load to ground, it is recommended to ground the output terminal as close as possible to the power supply's output. Always use two wires to connect the load to the power supply regardless of how the system is grounded.

CHAPTER 20 PARALLEL AND SERIES OPERATION

20.1 Parallel operation

Up to 3 x FPS-T1U racks with up to 8 x FPS1000 installed units of the same output voltage rating can be connected in parallel. The built-in Oring diodes on the main output and on the +12V auxiliary voltage in each FPS1000 unit allow N+1 operation. By connecting the CS signal between the paralleled units, automatic current balance is achieved, with +/-10% accuracy. For input voltages less than 100Vac, maximum output Power derated by 10% of the Power rating. Refer to Fig 20-1 for output Power derating in parallel operation.

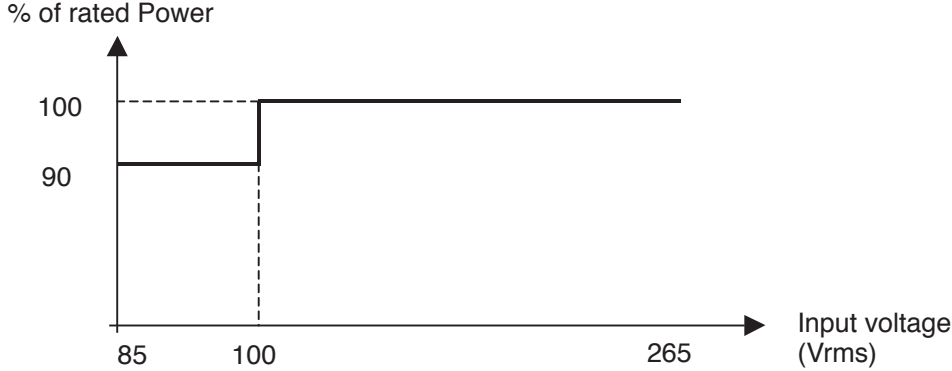

Fig 20-1

20.1.1 Parallel operation with Remote sensing

Fig 20-2 shows typical connection of parallel operation with Remote sensing. The CS signal wires should be as short as possible and with the same length.

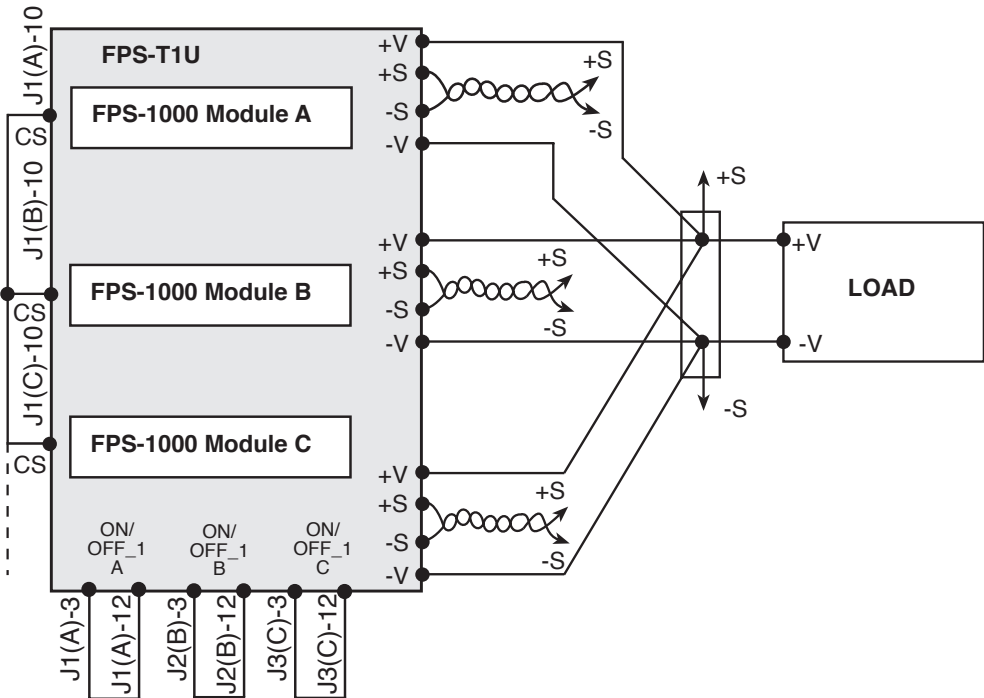

Fig 20-2 Parallel operation with Remote sensing

20.2 Series operation

Up to three FPS1000 with the same output voltage rating can be connected in series to increase the output voltage or to create a bipolar voltage source. It is recommended to connect diodes in parallel with each output to prevent reverse voltage in case of failure in one of the power supplies.

Each diode should be rated to at least the power supply rated output voltage and output current.

Refer to Fig 20-3 for a typical series connection of power supplies.

CAUTION

Series operation is not applicable for units with I²C bus option.

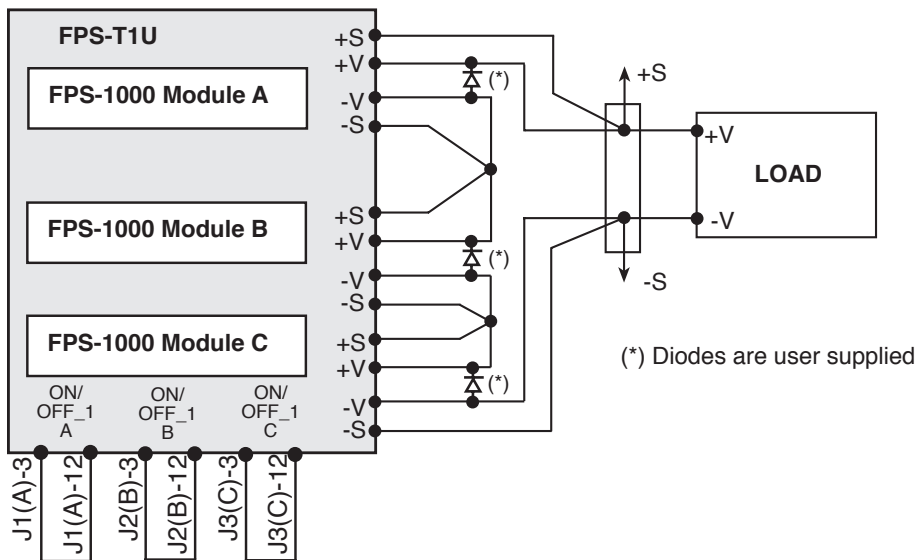

Fig 20-3 Series operation

CHAPTER 21 FPS-T1U I²C BUS INTERFACE OPTION

21.1 Introduction

The FPS-T1U rack provides access to the I²C Bus interface in each installed FPS1000/S unit via the rear panel MOLEX female connector located at the rear panel. The Clock is connected to pin 2 and the Data is connected to pin 1. The specifications of the I²C of the FPS1000/S power supplies are kept when they are installed in the FPS-T1U rack. Refer to Chapter 7 for the specifications and all operating details.

21.2 Addressing (A0, A1, A2).

The address line of the FPS1000/S units installed in the FPS-T1U rack are internally fixed. Refer to the following table for details:

	A0	A1	A2
Module "A"	1	1	1
Module "B"	0	1	1
Module "C"	1	0	1

Note: Address are applicable when modules FPS1000/S (I2C option) are used

CAUTION

The I²C bus address lines, serial clock and data are referenced to the -Sense potential. When using series connection of FPS-T1U racks, do not connect the I²C lines of the units together.

CHAPTER 22 FPS-T1U MAINTENANCE

22.1 Introduction

This chapter contains information about maintenance, calibration and troubleshooting of the FPS-T1U rack.

22.2 Units under warranty

Units requiring repairs during the warranty period should be returned to Densai-Lambda authorized service office. Unauthorized repairs performed by other than the authorized service facilities may void the warranty.

22.3 Periodic maintenance

No routine maintenance of the FPS-T1U rack is required except for periodic cleaning. To clean, disconnect the unit from the AC supply and allow 30sec. for discharging internal voltage. The FPS-T1U should be cleaned using mild solution of detergent and water. The solution should be applied onto a soft cloth, and not directly to the surface of the unit. Do not use aromatic hydrocarbons or chlorinated solvents for cleaning. Use low pressure compressed air to blow dust from the unit.

22.4 Adjustments and Calibration

No internal adjustment or calibration are required. Units that are returned for repair will be calibrated at the service office. In any case, opening the cover is not allowed.

22.5 Parts replacement and repair

As repairs are made only by the manufacturer or by its authorized service offices, no parts replacement information is given in this manual. In case of failure, unusual or erratic operation of the unit, contact your nearest Densai-Lambda sales and service office.

