

REVISIONS				
P	LTR	DESCRIPTION	DATE	APPV
A1		ADD PCB THICKNESS TOLERANCE, CORRECT TITLE	22SEP2016	JPS JLM

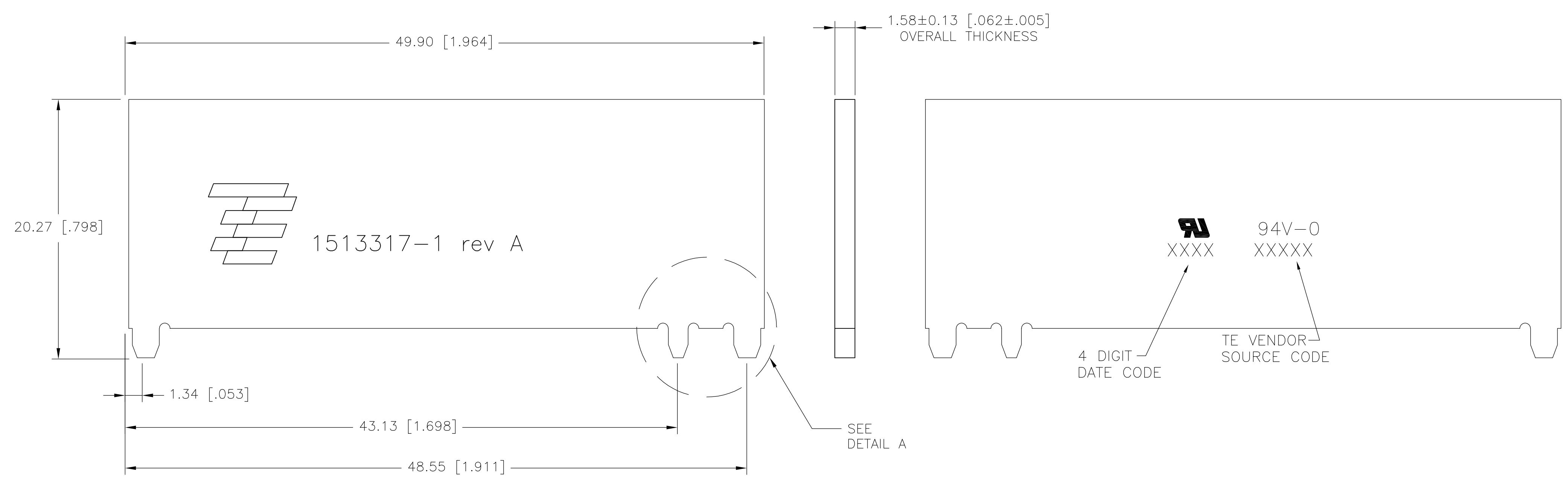

1513317-1 AS SHOWN
PRIMARY SIDE

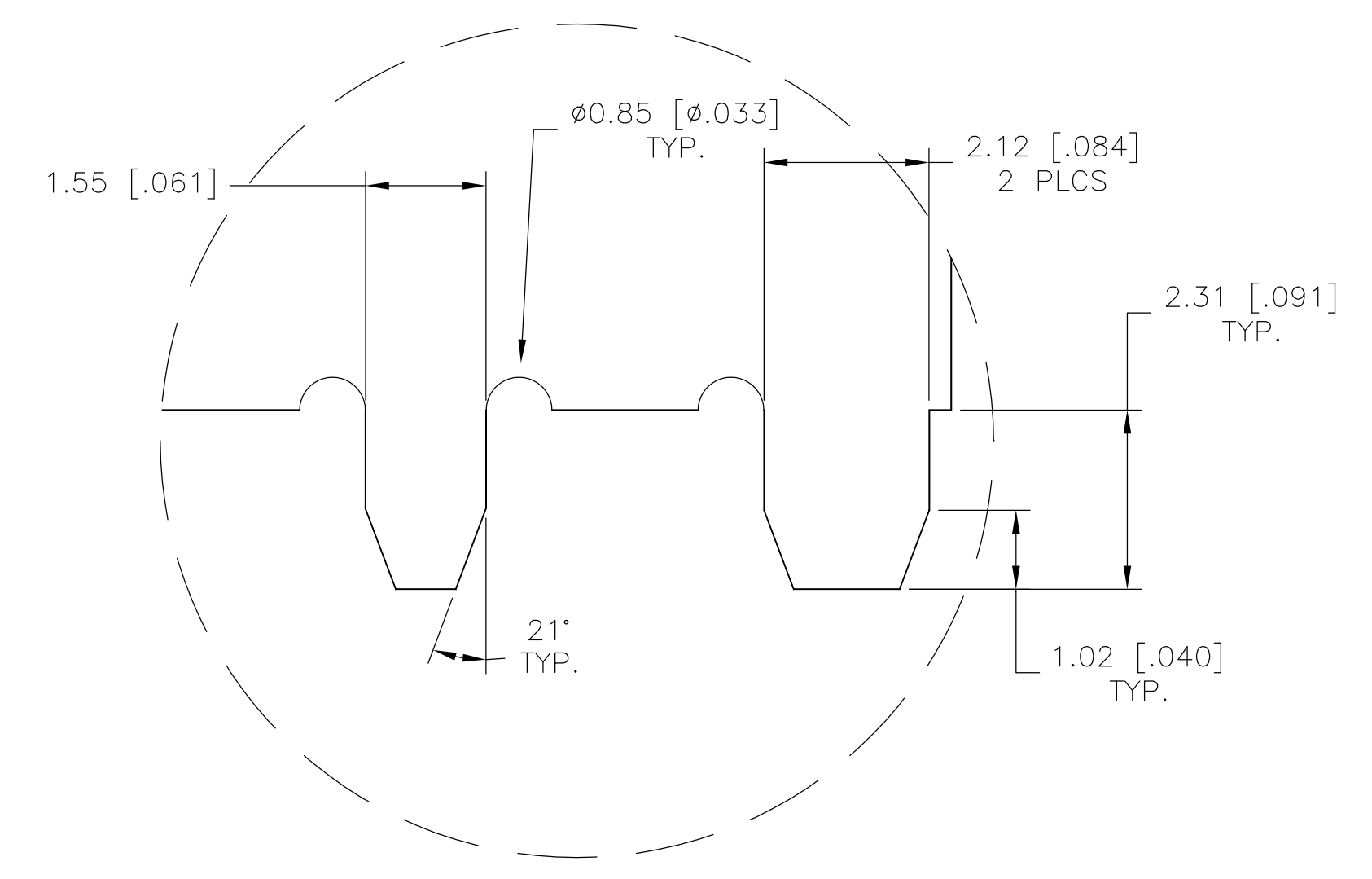

DETAIL A
SCALE 13:1

NOTES: UNLESS OTHERWISE SPECIFIED.

- FABRICATE TO MEET IPC - 6012, CLASS 2.
INSPECT TO MEET IPC - A - 600, CLASS 2.
- PRIMARY SIDE AND SECONDARY SIDE SHOWN.
- MATERIAL: GETEK 8 PLY (7628) 1.47 [.059] THK.
GRADE RG200D 1/2 OZ. COPPER BOTH SIDES.
DIELECTRIC CONSTANT @ 1MHZ 4.2±0.1.
- FINISH:
A: SOLDERMASK OVER BARE COPPER (SMOBC).
B: MASK BOTH SIDES OF PCB WITH LPI SOLDERMASK.
SOLDERMASK COLOR: NATURAL GREEN.
C: TOP AND BOTTOM OF TABS E.N.I.G PLATING
- TWO PLACE TOLERANCES: ±0.23
- PACKAGING: SINGULATED PARTS TO BE VACUUM PACKED
IN BULK.
- PARTS ARE COMPLIANT TO ROHS STANDARDS PER TYCO
ELECTRONICS STANDARD TEC-138-702.
- CONSULT TYCO ELECTRONICS DATA SHEET DS1513317
- CONTACT TYCO ELECTRONICS ENGINEERING
PRIOR TO DESIGNING INTO AN APPLICATION

THIS DRAWING IS A CONTROLLED DOCUMENT.		DIN D.WALLACE 05NOV2009	TE Connectivity	
DIMENSIONS: mm [INCHES]		CHK G.GRIFFITH 05NOV2009		
TOLERANCES UNLESS OTHERWISE SPECIFIED:		APPV G.GRIFFITH 05NOV2009	NAME 824-960 and 1710-2170 MHz	
0 PLG ± -		PRODUCT SPEC	PENTA BAND ANTENNA	
1 PLG ± -		APPLICATION SPEC	SIZE A1	CAGE CODE 00779
2 PLG ± -			DRAWING NO 1513317	RESTRICTED TO
3 PLG ± -			WEIGHT 0	
4 PLG ± -			CUSTOMER DRAWING	SCALE 1:1 SHEET 1 OF 1 REV A1
ANGLES ± -				