

DATE	DESCRIPTION	REV.
10.08.13	CHANGE AS PER ECN 13-091	A
1.04.17	CHANGE AS PER ECN17-005 (B) WAS 2.822 [71.64]	B
1.18.19	ECN 19-005, BASE WAS NYLON 46	C

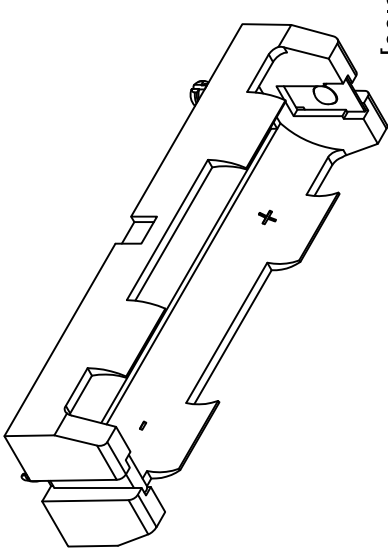
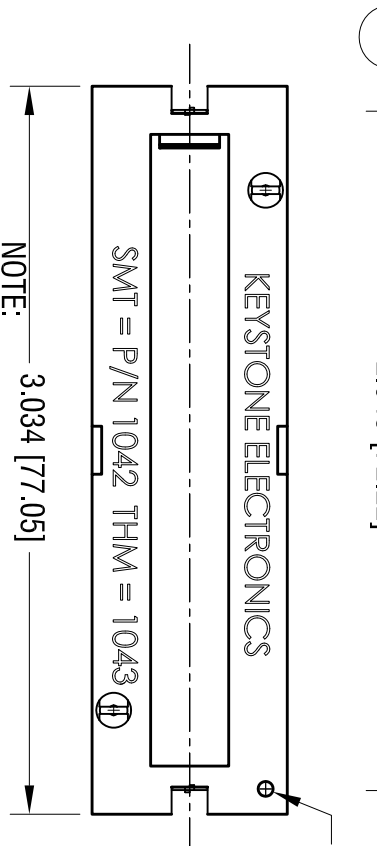
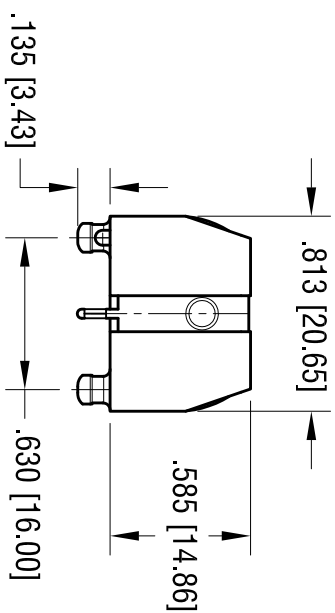
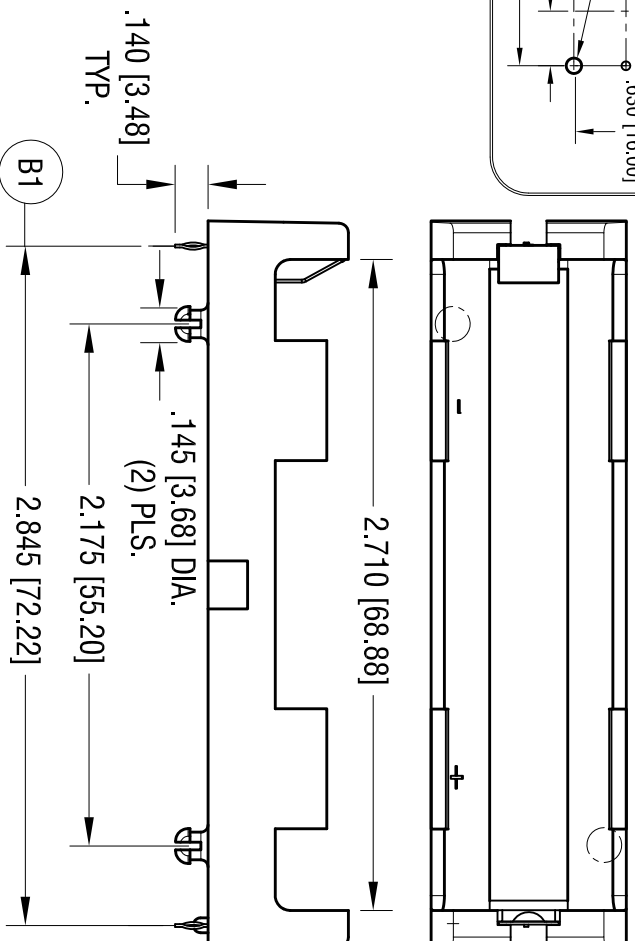
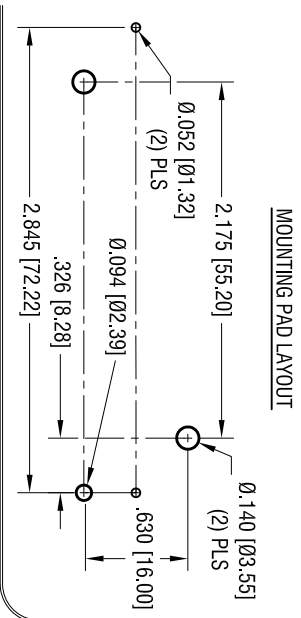

NOTE:

- 1. BASE:  
MAT'L: PBT (BLACK COLOR)
- 2. CONTACT:  
MAT'L: .012 [0.30] THK STAINLESS STEEL  
FINISH: TIN NICKEL PLATE

**KEYSTONE ELECTRONICS CORP.**  
www.keystec.com • NEW HYDE PARK, NY 11040 • Tel (516) 328-7500

PART NAME: THM POLARIZED HOLDER

MATERIAL: AS NOTED

FINISH: AS NOTED

TOLERANCES	INCH	[MM]	CODE	DWG NO.
DECIMAL	± .010	[± 0.25]	C	1043P
ANGULAR	± 1°			

THIS DOCUMENT IS THE PROPERTY OF KEYSTONE ELECTRONICS CORP. AND SHALL NOT BE REPRODUCED, DISTRIBUTED OR USED AS A BASIS FOR MANUFACTURE WITHOUT PRIOR WRITTEN PERMISSION FROM KEYSTONE ELECTRONICS CORP.

DRN BY: NT  
DATE: 7.12.13  
App'D: LN  
SCALE: 1.25X