

SECTION A-A
SCALE SECTION A-A

spec ref	-	dr	Eric Jiang	2013/01/14	projection	MM	size	A2	scale	1:1			
tolerance std	ISO 406 ISO 1101	eng	Sunny2 Liu	2016/05/05			ecn no	ELX-DG-24036-1	rel level	Released			
TOLERANCES UNLESS OTHERWISE SPECIFIED		chr	Terris Liu	2016/05/20							product family		
surface	ISO 1302	appr	Pei-Ming Zheng	2016/05/24			title	VERT RECT 16P HIGH POWER CARD EDGE		dwg no	10124021	rev	B
						cat. no.	Product - Customer Drw		sheet 1 of 4				

CONTACT TYPE	TOP LAYER DESCRIPTION	TABLE 1 (HPCE / SOLDER TAILS) PLATED THROUGH-HOLE REQUIREMENTS				
		DRILLED HOLE DIAMETER	COPPER THICKNESS	TIN-LEAD THICKNESS	TIN THICKNESS	FINISHED HOLE DIAMETER
POWER & SIGNAL	TIN-LEAD	1.10-1.16 (1.15 DRILL)	0.025 - 0.050	0.005 - 0.015	--	0.94 - 1.10
	IMMERSION TIN	1.10-1.16 (1.15 DRILL)	0.025 - 0.050	--	0.9 - 1.5um	0.94 - 1.10
	COPPER (SEE NOTE 8)	1.10-1.16 (1.15 DRILL)	0.025 - 0.050	--	--	0.94 - 1.10

CONTACT TYPE	TOP LAYER DESCRIPTION	TABLE 2 (HPCE / PRESS-FIT TAILS) PLATED THROUGH-HOLE REQUIREMENTS				
		DRILLED HOLE DIAMETER	COPPER THICKNESS	TIN-LEAD THICKNESS	TIN THICKNESS	FINISHED HOLE DIAMETER
POWER & SIGNAL	TIN-LEAD	0.81-0.86 (0.85 DRILL)	0.025 - 0.050	0.005 - 0.015	--	0.65 - 0.80
	IMMERSION TIN	0.81-0.86 (0.85 DRILL)	0.025 - 0.050	--	0.9 - 1.5um	0.70 - 0.80
	COPPER (SEE NOTE 8)	0.81-0.86 (0.85 DRILL)	0.025 - 0.050	--	--	0.70 - 0.80

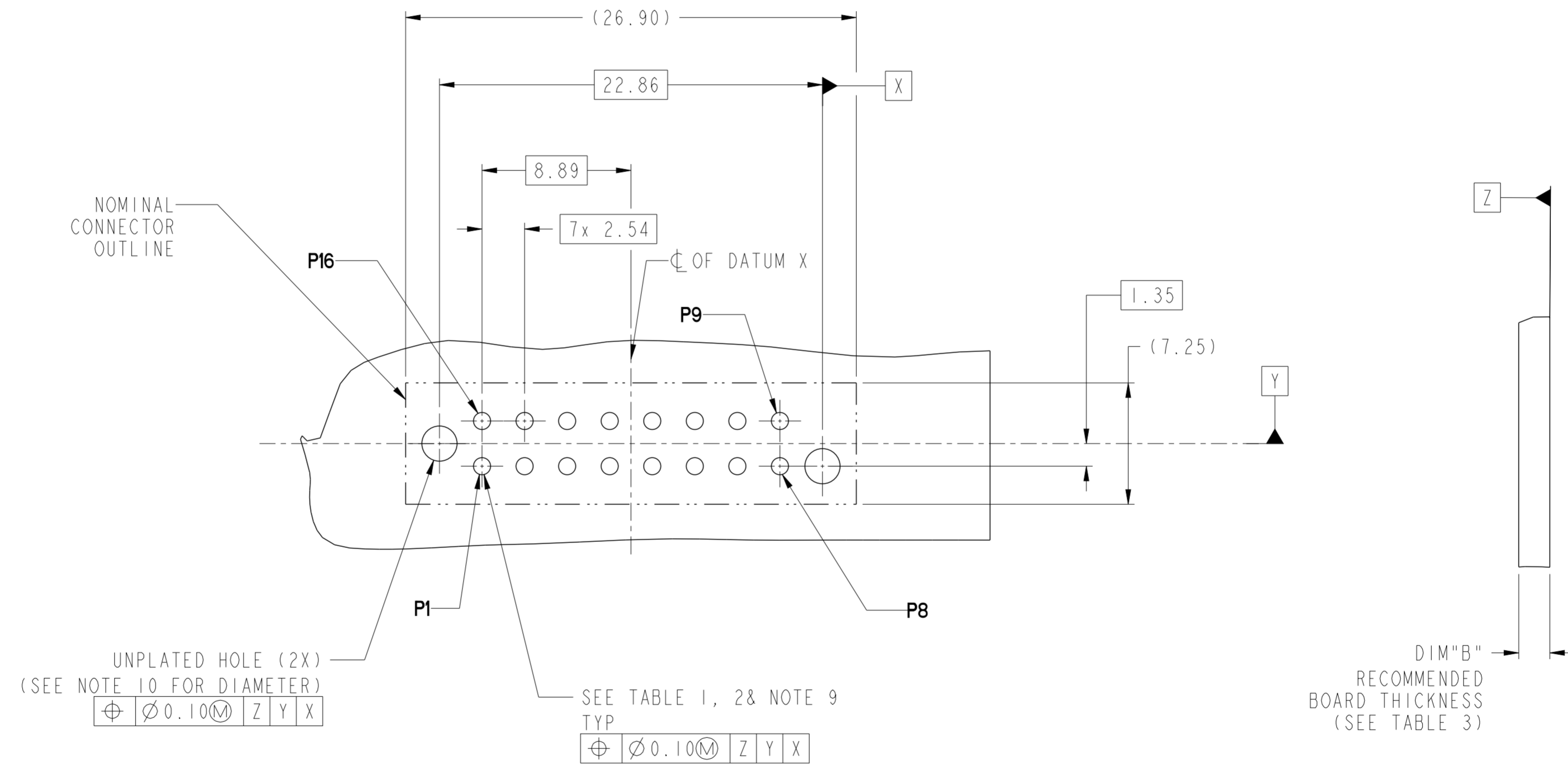

spec ref	-	dr	Eric Jiang	2013/01/14	projection	MM	size	A2	scale	1:1
tolerance std	ISO 406 ISO 1101	eng	Sunny2 Liu	2016/05/05			ecn no	ELX-DG-24036-1	rel level	Released
TOLERANCES UNLESS OTHERWISE SPECIFIED		chr	Terris Liu	2016/05/20						
		appr	Pai-Ming Zheng	2016/05/24						
surface	ISO 1302	linear	0.X	±0.5	Amphenol FCI		product family	VERT RECT 16P	cat. no.	10124021
		angular	0°	±2°	HIGH POWER CARD EDGE		Product - Customer Drw	sheet 2 of 4	rev	B

Amphenol FCI

© 2016 AFCI

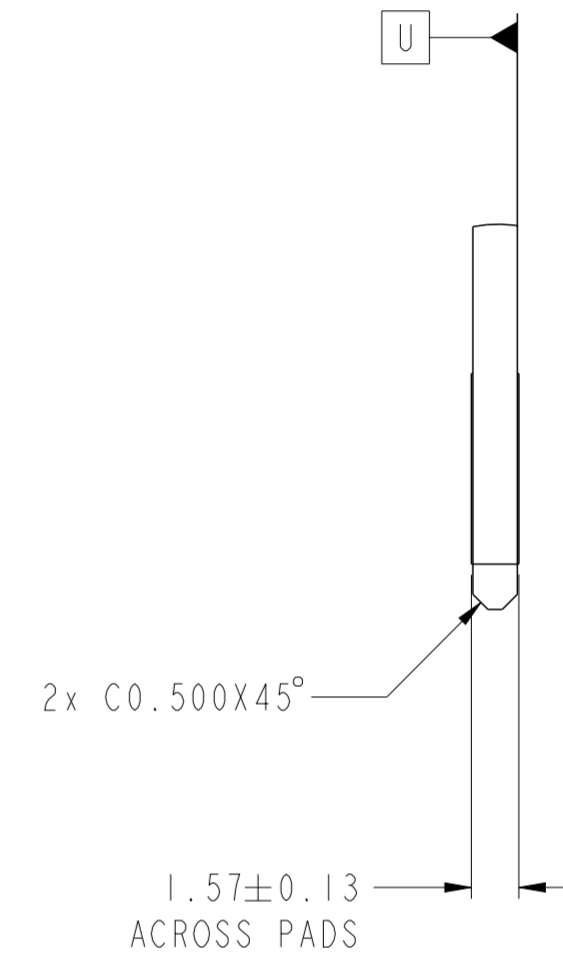
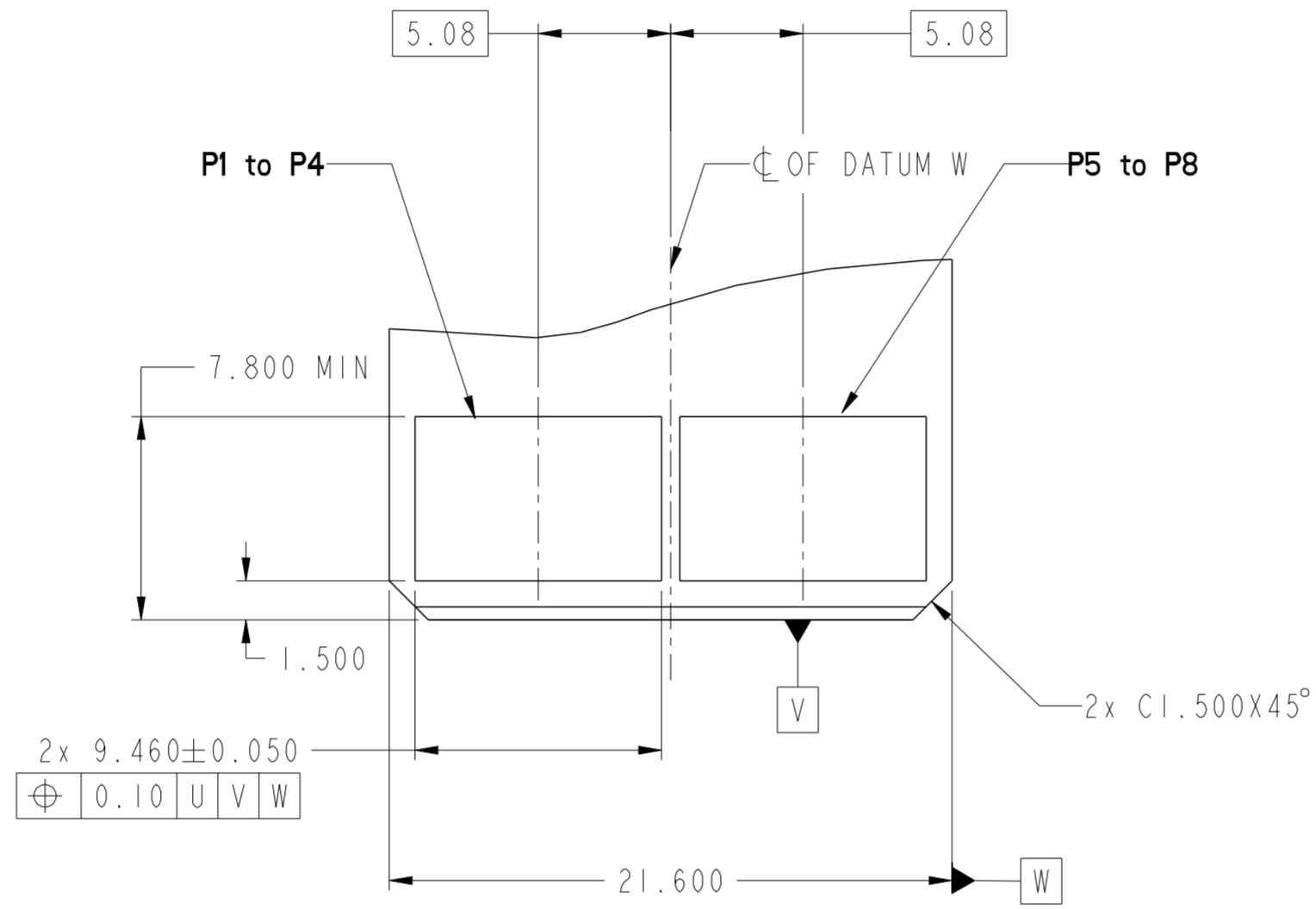

Amphenol
FCi

© 2016 AFci

spec ref	-	dr	Eric Jiang	2013/01/14	projection	MM	size	A2	scale	1:1	
tolerance std	ISO 406 ISO 1101	eng	Sunny2 Liu	2016/05/05			ecn no	ELX-DG-24036-1	rel level	Released	
TOLERANCES UNLESS OTHERWISE SPECIFIED		chr	Terris Liu	2016/05/20							
		appr	Pai-Ming Zheng	2016/05/24							
surface	ISO 1302	linear	0.X	±0.5				product family	VERT RECT 16P	cat. no.	Product - Customer Drw
			0.XX	±0.25				title	HIGH POWER CARD EDGE	dwg no	10124021
		angular	0°	±2°				rev	B	sheet 3 of 4	

HPCE PART NUMBER (TABLE 3)

PART NUMBER	TAIL TYPE	ORIENTATION KEY	DIM "A" TAIL LENGTH	DIM "B" RECOMMENDED BOARD THICKNESS
10124021-001LF	SOLDER	NO	3.17 ±0.25	1.59 - 2.38
10124021-002LF	PRESS-FIT	NO	3.17 ±0.25	1.57 MIN

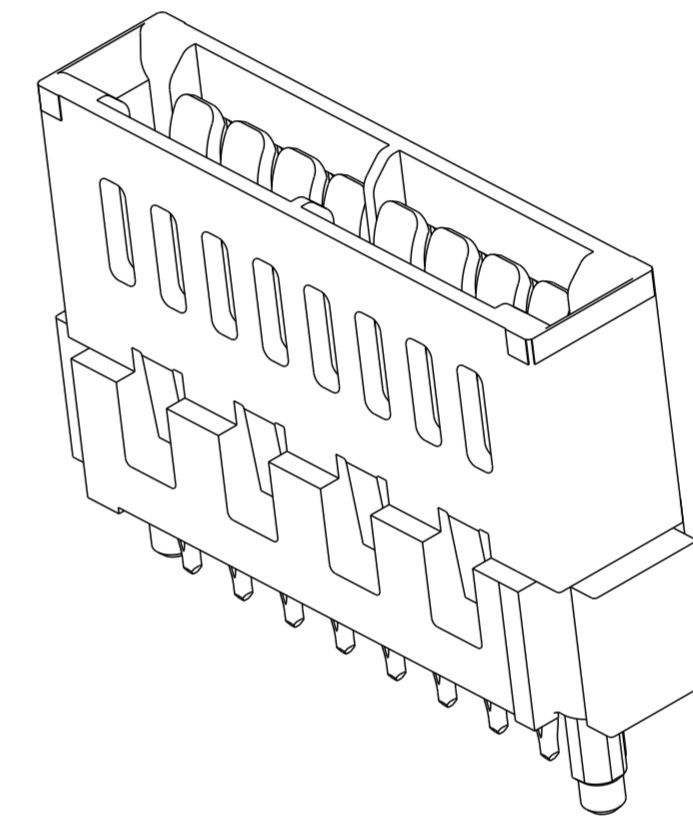

NOTES:

1. CONNECTOR MATERIALS:
 HOUSING: HIGH TEMPERATURE THERMAL PLASTIC, BLACK
 UL 94V-0 COMPLIANT
 CONTACTS: HIGH PERFORMANCE COPPER ALLOY.
2. CONTACT FINISH REF. GS-12-604 SECTION 5.2.
3. PRODUCT SPECIFICATION: GS-12-604.
4. APPLICATION SPECIFICATION: GS-20-128.
5. PRODUCT MARKING ON HOUSING IN AREA SHOWN MEETS AFCI SPECIFICATION: GS-24-007.
6. PACKAGING MEETS FCI SPECIFICATION GS-14-937.
7. HOUSING COMPONENT WILL WITHSTAND EXPOSURE TO 260°C PEAK TEMPERATURE FOR 60 SECONDS IN A CONVECTION, INFRA-RED, OR VAPOR PHASE REFLOW OVEN.
8. COPPER PLATING THICKNESS IN CENTER OF VIA-HOLE CAN BE NO MORE THAN 0.003 LESS THAN OTHER AREAS.
9. ALL HOLE SIZES ARE FINISHED HOLE SIZES.
10. MOUNTING HOLES ARE UNPLATED
 Ø 2.40 +/- 0.1 FOR PRESS-FIT TAILS
 Ø 2.18 +/- 0.03 FOR SOLDER TAILS
11. PRESS FIT APPLICATION TOOL DRAWING : 10119453.
12. A SYMBOL $\triangle B$ WILL BE NEXT TO ANY DIMENSION, VIEW, OR NOTE WHICH HAS BEEN MODIFIED WITH THE CURRENT DRAWING REVISION.

spec ref	-	dr	Eric Jiang	2013/01/14	projection	MM	size	A2	scale	1:1
tolerance std	ISO 406 ISO 1101	eng	Sunny2 Liu	2016/05/05			ecn no	ELX-DG-24036-1		
TOLERANCES UNLESS OTHERWISE SPECIFIED		chr	Terris Liu	2016/05/20			rel level	Released		
surface	ISO 1302	appr	Pei-Ming Zheng	2016/05/24	product family	Amphenol FCI		title	VERT RECT 16P HIGH POWER CARD EDGE	
	linear	0.X	±0.5		cat. no.	10124021		rev	B	
		0.XX	±0.25		Product - Customer Drw		sheet 4 of 4			
	angular	0°	±2°							