

## Fingerprint Scanner (#29126)

The Fingerprint Scanner is a convenient module for scanning, identifying, and storing fingerprints. Both a high-resolution camera and image processor, it is designed to make capturing, scanning, comparing, and managing the fingerprint information by user ID number easy. The module has a wide operating voltage range and low power consumption with an optional sleep mode for use in battery-powered systems.

The Fingerprint Scanner is useful for biometric locks, facility access control systems, personal identification systems.

### Features

- Onboard high-speed processor for fast identification
- High-accuracy optical sensor and commercial fingerprinting algorithm provide a solid performance
- Supports any microcontroller with UART for easy developing
- Open protocol that supports input/output of fingerprint images, fingerprint feature file, and user ID data

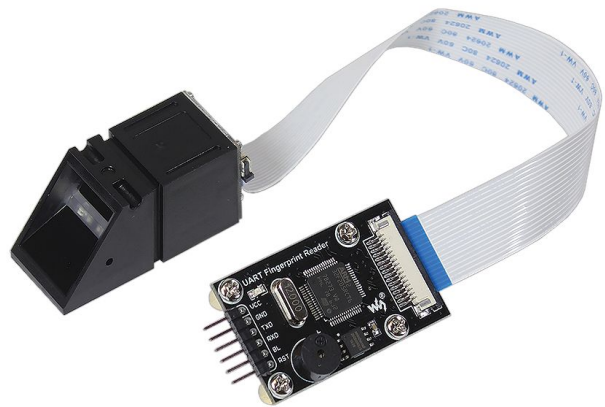

### Specifications

- Sensor: HD optical
- Memory: Built-in (extensible)
- Anti-wearing: 1 million times
- Anti-electrostatic: 150KV
- Fingerprint capacity: 1000 captures
- False acceptance rate: <0.001% (on security level 5)
- False rejection rate: <0.1% (on security level 5)
- Input time: <0.5s
- Matching time: <0.5s
- Matching modes: 1:1 and 1:N
- Security level: 1-10 (supports customization)
- Template rule standard: ISO19794-2
- Communication interface: UART, 9600-57600 bps
- Voltage requirement: 3.3-7.5V
- Current requirement: <50 mA
- Operating temperature: -4 to +140 °F (-20 to +60 °C)
- Relative humidity: 40% to 85% RH (without condensation)
- Approximate dimensions
  - PCB : 1.8 x 1.1 in (45.7 x 28.2 mm)
  - Camera : 2 x 0.9 x 1 in (50 x 23.2 x 25 mm)
  - Ribbon cable: 7.3 x 0.7 in (186 x 17 mm)

## Getting Started

The Fingerprint Scanner will need to be used with a microcontroller or computer capable of TTL-level UART serial communication at 19,200 bps.

The Fingerprint Scanner has three parts that need to be assembled:

- Camera module
- Ribbon Cable
- Printed Circuit Board (PCB) module

Connect the Camera module to the PCB module using the ribbon cable. Both the PCB and camera modules have ribbon cable connectors on them. The ribbon cable connector is grey, tan, or brown with a black latch. The black latch sticks out on both sides of the connector.

1. Using the tabs on the sides, gently pull the latch slightly away from the body of the ribbon connector cable on both the PCB and Camera modules.
2. Insert the ribbon cable into one of the connectors with the blue tab up and the metal connections down toward the module.
3. Push the latch back into the body of the ribbon connector.
4. Repeat for the other end of the ribbon cable into the other connector.

Connect the Pins on the PCB assembly to the microcontroller:

1. Connect the GND pin to ground.
2. Connect the VCC pin to the power supply (3.3V - 7.5V, whatever is appropriate for the safe logic levels of your microcontroller.)
3. Connect to the RXD and TXD pins to the UART or designated GPIO pins of your microcontroller.

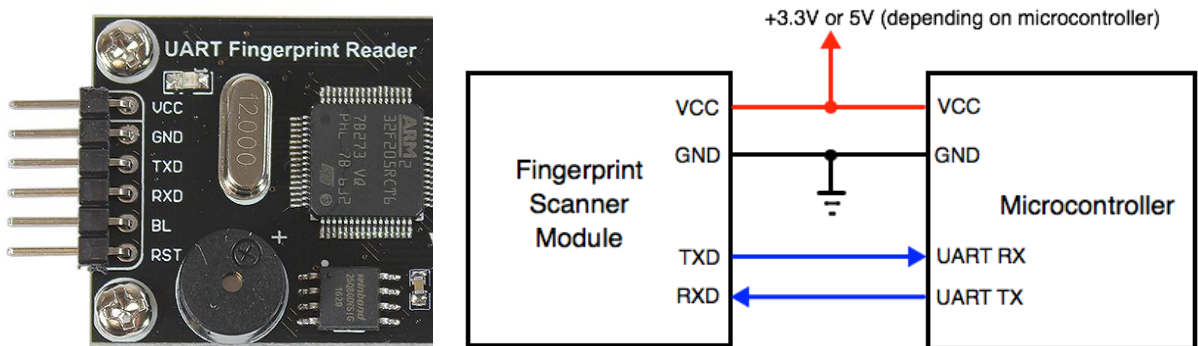

Now you are ready to load an example program into your microcontroller, and follow the prompts. Read through the rest of this document for tips on using the Fingerprint Scanner, and the most commonly used device commands.

Example code in C and Blockly are available for the Propeller P8X32A microcontroller. Example code in PBASIC is available for the BASIC Stamp 2 microcontroller.

See the Downloads and Additional Resources links on the Fingerprint Scanner product page: go to [www.parallax.com](http://www.parallax.com) and search 29126.

## Pin Definitions and Ratings

Pin	Name	Type	Function
1	VCC	P	Power connection, connect to voltage source from +3.3 to +7.5 VDC
2	GND	G	Ground connection
3	TXD	O	UART serial output, connect to MCU RX
4	RXD	I	UART serial input, connect to MCU TX
5	BL	I	Backlight (NO CONNECTION/NOT SUPPORTED)
6	RST	I	Reset, pull LOW to reset the module

Pin Type: P = Power, G = Ground, I = Input, O = Output

## Communication Protocol

The Fingerprint Scanner works as a slave device with the microcontroller (master device) controlling it by sending commands serially through a UART interface. The command interface: 19,200 bps, 1 start bit, 1 stop bit, no parity (8N1).

Commands sent from the microcontroller (master device) to the Fingerprint Scanner must be in the following formats:

### Command Packet

Byte	1	2	3	4	5	6	7	8
Value	<b>0xF5</b>					<b>0x00</b>		<b>0xF5</b>

Where:

- : One of the defined command bytes
- : Command parameters
- : XOR checksum of bytes 2-6: (Byte1 ^ Byte2 ^ Byte3 ^ Byte4 ^ Byte5 ^ Byte6)

When the command packet is received, the module will respond with a similarly formatted 8 byte packet:

### Response Packet

Byte	1	2	3	4	5	6	7	8
Value	<b>0xF5</b>					<b>0x00</b>		<b>0xF5</b>

Where:

- : One of the defined command bytes
- : Returned values
- : XOR checksum of bytes 2-6: (Byte1 ^ Byte2 ^ Byte3 ^ Byte4 ^ Byte5 ^ Byte6)

is used mainly to return the summary result of the command operation, and is usually one of the following values:

```
#define ACK_SUCCESS      0x00 // Operation successful
#define ACK_FAIL        0x01 // Operation failed
#define ACK_FULL        0x04 // Fingerprint database is full
#define ACK_NOUSER      0x05 // No such user
```

```
#define ACK_USER_EXISTS 0x07 // already exists
#define ACK_TIMEOUT    0x08 // Acquisition timeout
```

Some commands require data to be transferred to or from the module. These commands are sent/received in two parts: the Command/Response Packet + a Command/Response Data Package:

The first part of the message, the Command/Response packet, is the same as above, with the following information:

Command version (sending):

- = HIGHBYTE of the **length** of message (in bytes) where **length** is a 16-bit unsigned integer
- = HIGHBYTE of the **length** of message (in bytes) where **length** is a 16-bit unsigned integer
- = **0x00**

Response version (

- = HIGHBYTE of the **length** of message (in bytes) where **length** is a 16-bit unsigned integer
- = HIGHBYTE of the **length** of message (in bytes) where **length** is a 16-bit unsigned integer
- = **summary result** (defined above)

## Data Package

Byte	1	2	...	Length + 1	Length + 2	Length + 3
Value	<b>0xF5</b>					<b>0x00</b>

: XOR checksum of all Data bytes.

## Command Set

These are the commands most likely to be used in normal operation. The full command set and communication protocol is available from the Downloads section of the Fingerprint Scanner product page at [www.parallax.com](http://www.parallax.com) (search 29126).

Command	Description	Parameter 1	Parameter 2	Parameter 3	Possible Responses
<b>0x01</b>	Add Fingerprint Capture (first scan)	<b>User ID HIGHBYTE</b>	<b>User ID LOWBYTE</b>	<b>User "level" (1, 2, or 3)</b>	<i>Value3</i> = ACK_SUCCESS ACK_FAIL ACK_FULL ACK_TIMEOUT
<b>0x02</b>	Add Fingerprint Capture (first scan)	<b>User ID HIGHBYTE</b>	<b>User ID LOWBYTE</b>	<b>User "level" (1, 2, or 3)</b>	<i>Value3</i> = ACK_SUCCESS ACK_FAIL ACK_TIMEOUT
<b>0x03</b>	Add Fingerprint Capture (first scan)	<b>User ID HIGHBYTE</b>	<b>User ID LOWBYTE</b>	<b>User "level" (1, 2, or 3)</b>	<i>Value3</i> = ACK_SUCCESS ACK_FAIL ACK_USER_EXISTS ACK_TIMEOUT

<b>0x04</b>	Delete Specified User	<b>User ID HIGHBYTE</b>	<b>User ID LOWBYTE</b>	<b>0x00</b>	<i>Value3</i> = ACK_SUCCESS ACK_FAIL
<b>0x05</b>	Delete All Users	<b>0x00</b>	<b>0x00</b>	<b>0x00</b>	<i>Value3</i> = ACK_SUCCESS ACK_FAIL
<b>0x09</b>	Count number of saved users	<b>0x00</b>	<b>0x00</b>	<b>0x00</b>	<i>Value1</i> = Count.HIGHBYTE <i>Value2</i> = Count.LOWBYTE <i>Value3</i> = ACK_SUCCESS ACK_FAIL
<b>0x0A</b>	Acquire User "level"	<b>User ID HIGHBYTE</b>	<b>User ID LOWBYTE</b>	<b>0x00</b>	<i>Value3</i> = User "level" (1,2,or 3) ACK_NOUSER
<b>0x0B</b>	Compare scan to a specified user's saved capture (1:1)	<b>User ID HIGHBYTE</b>	<b>User ID LOWBYTE</b>	<b>0x00</b>	<i>Value3</i> = ACK_SUCCESS ACK_FAIL ACK_TIMEOUT
<b>0x0C</b>	Scan and try to find a match to a saved capture (1:N)	<b>0x00</b>	<b>0x00</b>	<b>0x00</b>	<i>Value1</i> = UserID.HIGHBYTE <i>Value2</i> = UserID.LOWBYTE <i>Value3</i> = User "level" (1,2,or 3) ACK_NOUSER ACK_TIMEOUT

## Using the Fingerprint Scanner

If you are using the Fingerprint Scanner for the first time, it is helpful to first issue a command to delete all users (**0x05**). This ensures that you are starting with a clean, blank memory bank. Make sure that the module returns ACK\_SUCCESS.

### Capturing the fingerprint of a new user

When adding a new fingerprint image capture, you will assign it a user ID (you may save up to 1000 different captures, and the user ID can be any number from 1 to 65535). The fingerprint must be scanned three times, each time using the next "add fingerprint command" - **0x01**, **0x02**, then **0x03**. You must also set a "level" of 1, 2, or 3 for the user. The meaning of the "level"s are up to you.

### Using the Fingerprint Scanner to identify a fingerprint

Once a user's fingerprint has been captured and saved, you can use the Compare 1:1 (**0x0B**) or Compare 1:N (**0x0C**) commands to identify new scans. Compare 1:1 will determine if the fingerprint being scanned matches a specific user ID, and Compare 1:N tries to match the fingerprint being scanned to one of the saved captures in its memory.

## PCB Dimensions

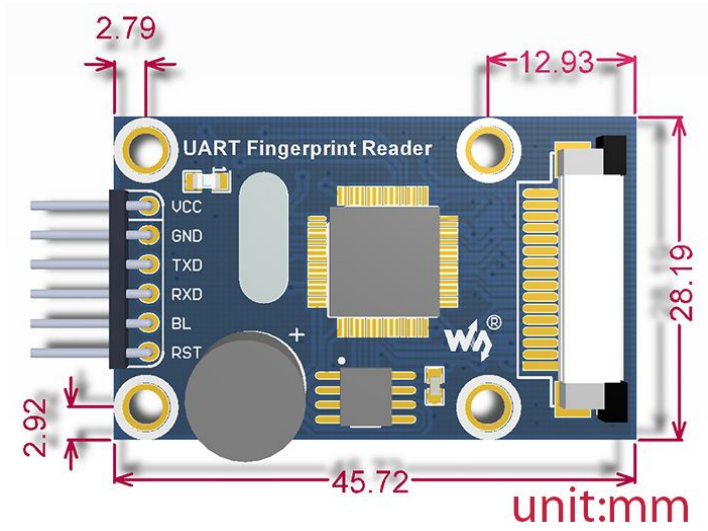

## Camera Dimensions

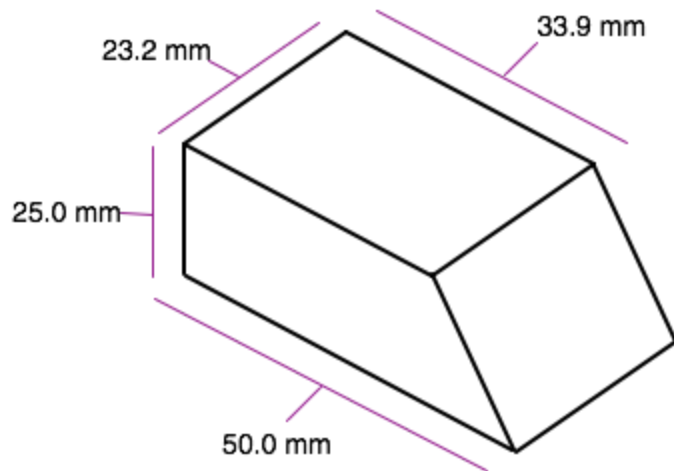

## Revision History:

V1.0 - Original release.