

THIS DOCUMENT IS THE PROPERTY OF KEYSTONE ELECTRONICS CORP. AND SHALL NOT BE REPRODUCED, DISTRIBUTED OR USED AS A BASIS FOR MANUFACTURE WITHOUT PRIOR WRITTEN PERMISSION FROM KEYSTONE ELECTRONICS CORP.

ACTUAL SIZE

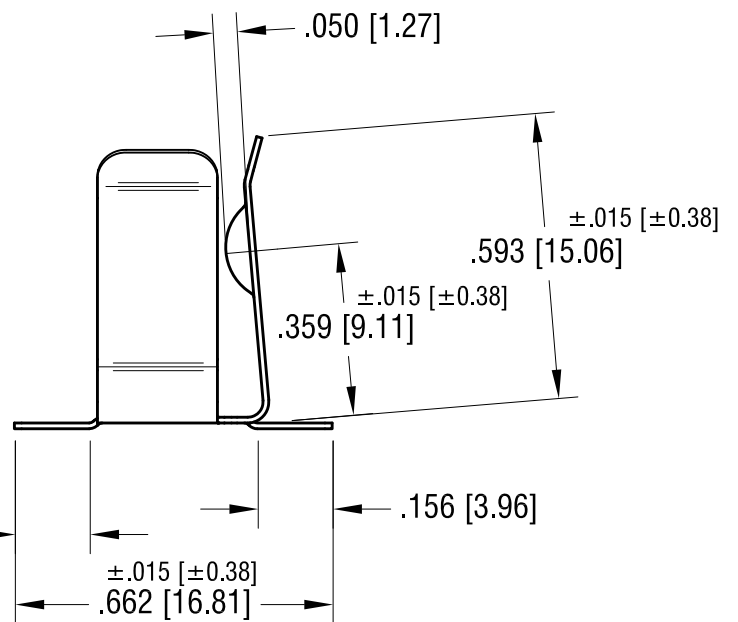

MOUNTING PAD LAYOUT. REQUIRED SPACING FOR 'A' OR 'AA' BATTERIES

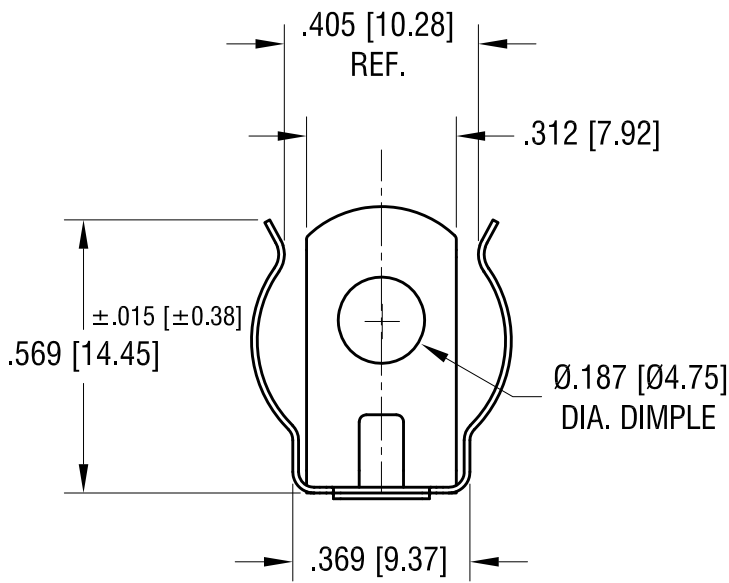
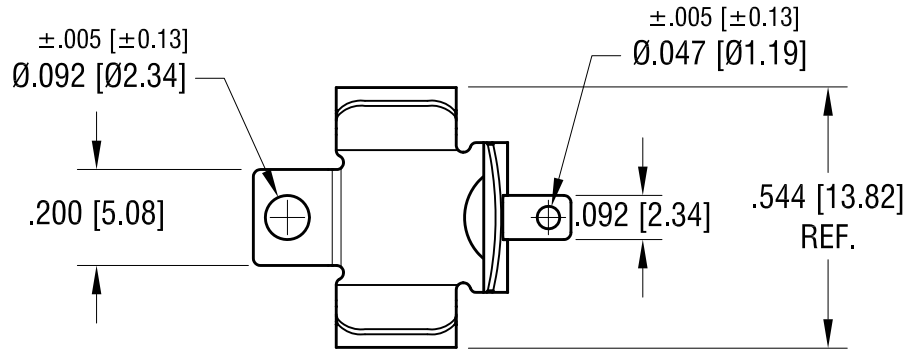
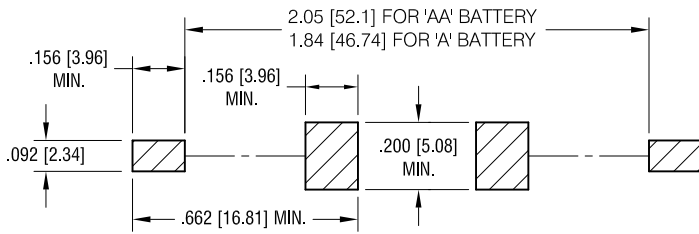

NOTE:

1. HEAT TREAT TO SPRING TEMPER.

KEYSTONE ELECTRONICS CORP.

www.keyelco.com • NEW HYDE PARK, NY 11040 • Tel (516) 328-7500

PART NAME

'A' & 'AA' BATTERY HOLDER

MATERIAL

.012 [0.30] TH'K ANNEALED SPRING STEEL

FINISH

TIN NICKEL PLATE

DRN BY

NT

DATE

10.16.08

APP'D

LN

SCALE

2.5X

TOLERANCES

INCH [MM]

DECIMAL

±.010 [±0.25]

ANGULAR

± 2°

UNLESS OTHERWISE SPECIFIED

CODE

C

DWG NO.

53

DATE	DESCRIPTION	REV.
10.06.16	CHANGE AS PER ECR 16-067	C
10.20.09	CHANGE AS PER ECN 99-152	B
1.05.09	CHANGE AS PER ECN 09-001	A