

3-Wire Hall Effect Latch

Features and Benefits

- Wide operating voltage range: from 2.7V to 24V
- Chopper-stabilized amplifier stage
- Built-in negative temperature coefficient
- Reverse Supply Voltage Protection
- High ESD rating / Excellent EMC performance

Applications

- Consumer and Industrial
- Solid-state switch
- E-Bike
- Motorcycles
- 3-phase BLDC motor commutation

Ordering information

| Part No. | Temperature Code | Package Code | Comment |
|------------------------|--------------------|--------------|---|
| MLX92215LUA-AAA-000-BU | L (-40°C to 150°C) | UA (TO92-3L) | $B_{OP}/B_{RP} = \pm 3\text{mT}$, $TC = -1100 \text{ ppm}/^\circ\text{C}$ |
| MLX92215LSE-AAA-000-RE | L (-40°C to 150°C) | SE (TSOT-23) | $B_{OP}/B_{RP} = \pm 3\text{mT}$, $TC = -1100 \text{ ppm}/^\circ\text{C}$ |
| MLX92215LSE-ACA-000-RE | L (-40°C to 150°C) | SE (TSOT-23) | $B_{OP}/B_{RP} = \pm 3\text{mT}$, $TC = -2000 \text{ ppm}/^\circ\text{C}$ Inverted output |
| MLX92215LUA-AEA-000-RE | L (-40°C to 150°C) | UA (TO92-3L) | $B_{OP}/B_{RP} = \pm 3\text{mT}$, $TC = -1100 \text{ ppm}/^\circ\text{C}$ |
| MLX92215LSE-AEA-000-RE | L (-40°C to 150°C) | SE (TSOT-23) | $B_{OP}/B_{RP} = \pm 3\text{mT}$, $TC = -1100 \text{ ppm}/^\circ\text{C}$ |

1. Functional Diagram

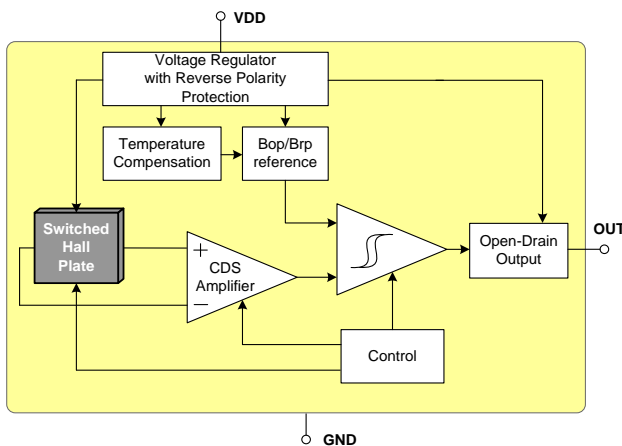

2. General Description

The Melexis MLX92215 is the second generation Hall-effect latch designed in mixed signal CMOS technology.

The device integrates a voltage regulator, Hall sensor with advanced offset cancellation system and an open-drain output driver, all in a single package. Based on the existing platform, the magnetic core is using an improved offset cancellation system allowing faster and more accurate processing while being temperature insensitive and stress independent. In addition is implemented a negative temperature coefficient to compensate the natural behaviour of magnets becoming weaker with rise in temperature.

The included voltage regulator operates from 2.7V to 24V, hence covering a wide range of applications. With the built-in reverse voltage protection, a serial resistor or diode on the supply line is not required so that even remote sensors can be specified for low voltage operation down to 2.7V while being reverse voltage tolerant.

With latching magnetic characteristics, the output is turned low or high respectively with a sufficiently strong South or North pole facing the package top side. When removing the magnetic field, the device keeps its previous state.

Contents

| | |
|--|----|
| Features and Benefits..... | 1 |
| Applications..... | 1 |
| Ordering information | 1 |
| 1. Functional Diagram | 1 |
| 2. General Description..... | 1 |
| 3. Glossary of Terms..... | 3 |
| 4. Absolute Maximum Ratings..... | 4 |
| 5. General Electrical Specifications..... | 5 |
| 6. Magnetic Specifications..... | 6 |
| 6.1. MLX92215LSE-AAA-000..... | 6 |
| 6.2. MLX92215LUA-AAA-000..... | 6 |
| 6.3. MLX92215LSE-ACA-000..... | 6 |
| 6.4. MLX92215LUA-AEA-000..... | 6 |
| 6.5. MLX92215LSE-AEA-000..... | 7 |
| 7. Output Behavior versus Magnetic Pole | 8 |
| 7.1. South Pole Active | 8 |
| 7.2. North Pole Active | 8 |
| 8. Performance Graphs | 9 |
| 8.1. Magnetic parameters vs. T_A | 9 |
| 8.2. Magnetic parameters vs. V_{DD} | 9 |
| 8.3. V_{DSon} vs. T_A | 9 |
| 8.4. V_{DSon} vs. V_{DD} | 9 |
| 8.5. I_{DD} vs. T_A | 9 |
| 8.6. I_{DD} vs. V_{DD} | 9 |
| 8.7. I_{OFF} vs. T_A | 10 |
| 8.8. I_{OFF} vs. V_{OUT} | 10 |
| 8.9. SE Power Derating vs. T_A | 10 |
| 8.10. UA Power Derating vs. T_A | 10 |
| 9. Application Information..... | 11 |
| 9.1. Typical Three-Wire Application Circuit..... | 11 |
| 10. Standard information regarding manufacturability of Melexis products with different soldering processes..... | 12 |
| 11. ESD Precautions | 12 |

12. Packages.....13

 12.1. SE Package (TSOT-23) package information.....13

 1.1 UA (TO92 - 3L) package information.....14

13. Contact.....15

14. Disclaimer.....15

3. Glossary of Terms

| | |
|------------------------|---|
| MilliTesla (mT), Gauss | Units of magnetic flux density: 1mT = 10 Gauss |
| RoHS | Restriction of Hazardous Substances |
| TSOT | Thin Small Outline Transistor (TSOT package) – also referred with the Melexis package code “SE” |
| ESD | Electro-Static Discharge |

4. Absolute Maximum Ratings

| Parameter | Symbol | Value | Units |
|--|---------------------|-------------|-------|
| Supply Voltage ^(1, 2) | V _{DD} | +27 | V |
| Supply Voltage (Load dump) ^(1, 3) | V _{DD} | +32 | V |
| Supply Current ^(1, 2, 4) | I _{DD} | +20 | mA |
| Supply Current ^(1, 3, 4) | I _{DD} | +50 | mA |
| Reverse Supply Voltage ^(1, 2) | V _{DDREV} | -24 | V |
| Reverse Supply Voltage (Load dump) ^(1, 3) | V _{DDREV} | -30 | V |
| Reverse Supply Current ^(1, 2, 5) | I _{DDREV} | -20 | mA |
| Reverse Supply Current ^(1, 3, 5) | I _{DDREV} | -50 | mA |
| Output Voltage ^(1, 2) | V _{OUT} | +27 | V |
| Output Current ^(1, 2, 5) | I _{OUT} | +20 | mA |
| Output Current ^(1, 3, 6) | I _{OUT} | +75 | mA |
| Reverse Output Voltage ⁽¹⁾ | V _{OUTREV} | -0.5 | V |
| Reverse Output Current ^(1, 2) | I _{OUTREV} | -50 | mA |
| Operating Temperature Range | T _A | -40 to +150 | °C |
| Storage Temperature Range | T _S | -55 to +165 | °C |
| Maximum Junction Temperature ⁽⁷⁾ | T _J | +165 | °C |
| ESD Sensitivity – HBM ^{(8) (9)} | - | 4000 | V |
| ESD Sensitivity – HBM ^{(8) (10)} | - | 8000 | V |
| ESD Sensitivity – MM ⁽¹¹⁾ | - | 500 | V |
| ESD Sensitivity – CDM ⁽¹²⁾ | - | 1000 | V |
| Magnetic Flux Density | B | Unlimited | mT |

Exceeding the absolute maximum ratings may cause permanent damage. Exposure to absolute-maximum-rated conditions for extended periods may affect device reliability.

¹ The maximum junction temperature should not be exceeded

² For maximum 1 hour

³ For maximum 0.5 s

⁴ Including current through protection device

⁵ Through protection device

⁶ For $V_{OUT} \leq 27V$

⁷ For 1000 hours

⁸ Human Model according AEC-Q100-002 standard

⁹ Valid for version AAA and ACA

¹⁰ Valid for version AEA

¹¹ Machine Model according AEC-Q100-003 standard

¹² Charged Device Model according AEC-Q100-011 standard

5. General Electrical Specifications

DC Operating Parameters $T_A = -40^{\circ}\text{C}$ to 150°C , $V_{DD} = 2.7\text{V}$ to 24V (unless otherwise specified)

| Parameter | Symbol | Test Conditions | Min | Typ ⁽¹⁾ | Max | Units |
|--|--------------|---|-----|--------------------|-----|-----------------------------|
| Supply Voltage | V_{DD} | Operating | 2.7 | - | 24 | V |
| Supply Current | I_{DD} | | 1.5 | 3.0 | 4.5 | mA |
| Reverse Supply Current | I_{DDREV} | $V_{DD} = -18\text{V}$ | | | 1 | mA |
| Output Leakage Current | I_{OFF} | $V_{OUT} = 12\text{V}$, $V_{DD} = 12\text{V}$, $B < Brp$ | | 0.1 | 10 | μA |
| Output Saturation Voltage | V_{DSON} | $B > B_{OP}$, $V_{DD} = 3.8$ to 18V , $I_{OUT} = 20\text{mA}$ | | 0.2 | 0.5 | V |
| Output Rise Time ⁽²⁾ (R_{PU} dependent) | t_R | $V_{DD} = 12\text{V}$, $V_{PU}^{(3)} = 5\text{V}$, $R_{PU} = 1\text{k}\Omega$ $C_{LOAD} = 50\text{pF}$ to GND | 0.1 | 0.3 | 1 | μs |
| Output Fall Time ⁽²⁾ (On-chip controlled) | t_F | $V_{DD} = 12\text{V}$, $V_{PU} = 5\text{V}$, $R_{PU} = 1\text{k}\Omega$ $C_{LOAD} = 50\text{pF}$ to GND | 0.1 | 0.3 | 1 | μs |
| Chopping Frequency | f_{CHOP} | | | 340 | | kHz |
| Output Refresh Period ⁽²⁾ | t_{PER} | | | 6 | | μs |
| Delay time ^(2,4) | t_D | Average over 1000 successive switching events @10kHz, square wave with $B \geq 30\text{mT}$, $t_{RISE} = t_{FALL} \leq 20\mu\text{s}$ | | 6 | | μs |
| Output Jitter (p-p) ^(2,5) | t_{JITTER} | Over 1000 successive switching events @1kHz, square wave with $B \geq 30\text{mT}$, $t_{RISE} = t_{FALL} \leq 100\mu\text{s}$ | | ± 3 | | μs |
| Maximum Switching Frequency ^(2,6) | f_{SW} | $B \geq 30\text{mT}$ and square wave magnetic field | 30 | 50 | | kHz |
| Power-On Time ^(7,8) | t_{ON} | $V_{DD} = 5\text{V}$, $dV_{DD}/dt > 2\text{V}/\mu\text{s}$ | | 16 | 35 | μs |
| SE Package Thermal Resistance | R_{TH} | Single layer (1S) Jedec board | | 300 | | $^{\circ}\text{C}/\text{W}$ |
| UA Package Thermal Resistance | R_{TH} | Single layer (1S) Jedec board | | 200 | | $^{\circ}\text{C}/\text{W}$ |

¹ Typical values are defined at $T_A = +25^{\circ}\text{C}$ and $V_{DD} = 12\text{V}$

² Guaranteed by design and verified by characterization, not production tested

³ R_{PU} and V_{PU} are respectively the external pull-up resistor and pull-up power supply

⁴ The Delay Time is the time from magnetic threshold reached to the start of the output switching

⁵ Output jitter is the unpredictable deviation of the Delay time

⁶ Maximum switching frequency corresponds to the maximum frequency of the applied magnetic field which is detected without loss of pulses

⁷ The Power-On Time represents the time from reaching $V_{DD} = V_{POR}$ to the first refresh of the output (first valid output state)

⁸ Power-On Slew Rate is not critical for the proper device start-up

6. Magnetic Specifications

6.1. MLX92215LSE-AAA-000

DC Operating Parameters $V_{DD} = 3.8$ to $24V$, $T_A = -40^{\circ}C$ to $150^{\circ}C$

| Test Condition | Operating Point B_{OP} (mT) | | | Release Point B_{RP} (mT) | | | TC (ppm/ $^{\circ}C$) | Active Pole |
|----------------------|----------------------------------|--------------------|-----|--------------------------------|--------------------|------|---------------------------|-------------|
| | Min | Typ ⁽¹⁾ | Max | Min | Typ ⁽¹⁾ | Max | | |
| $T_J = -40^{\circ}C$ | 1 | 3.2 | 5 | -5 | -3.2 | -1 | -1100 | South Pole |
| $T_J = 25^{\circ}C$ | 1 | 3 | 5 | -5 | -3.0 | -1 | | |
| $T_J = 150^{\circ}C$ | 0.5 | 2.6 | 5 | -5 | -2.6 | -0.5 | | |

6.2. MLX92215LUA-AAA-000

DC Operating Parameters $V_{DD} = 3.8$ to $24V$, $T_A = -40^{\circ}C$ to $150^{\circ}C$

| Test Condition | Operating Point B_{OP} (mT) | | | Release Point B_{RP} (mT) | | | TC (ppm/ $^{\circ}C$) | Active Pole |
|----------------------|----------------------------------|--------------------|-----|--------------------------------|--------------------|------|---------------------------|-------------|
| | Min | Typ ⁽¹⁾ | Max | Min | Typ ⁽¹⁾ | Max | | |
| $T_J = -40^{\circ}C$ | 1 | 3.2 | 5 | -5 | -3.2 | -1 | -1100 | South Pole |
| $T_J = 25^{\circ}C$ | 1 | 3 | 5 | -5 | -3.0 | -1 | | |
| $T_J = 150^{\circ}C$ | 0.5 | 2.6 | 5 | -5 | -2.6 | -0.5 | | |

6.3. MLX92215LSE-ACA-000

DC Operating Parameters $V_{DD} = 3.8$ to $24V$, $T_A = -40^{\circ}C$ to $150^{\circ}C$

| Test Condition | Operating Point B_{OP} (mT) | | | Release Point B_{RP} (mT) | | | TC (ppm/ $^{\circ}C$) | Active Pole |
|----------------------|----------------------------------|--------------------|-----|--------------------------------|--------------------|------|---------------------------|-------------|
| | Min | Typ ⁽¹⁾ | Max | Min | Typ ⁽¹⁾ | Max | | |
| $T_J = -40^{\circ}C$ | 1.2 | 3.2 | 5.5 | -5.5 | -3.2 | -1.2 | -2000 | North Pole |
| $T_J = 25^{\circ}C$ | 1.0 | 2.8 | 4.7 | -4.7 | -2.8 | -1.0 | | |
| $T_J = 150^{\circ}C$ | 0.5 | 2.1 | 4.2 | -4.2 | -2.1 | -0.5 | | |

6.4. MLX92215LUA-AEA-000

DC Operating Parameters $V_{DD} = 3.8$ to $24V$, $T_A = -40^{\circ}C$ to $150^{\circ}C$

| Test Condition | Operating Point B_{OP} (mT) | | | Release Point B_{RP} (mT) | | | TC (ppm/ $^{\circ}C$) | Active Pole |
|----------------------|----------------------------------|--------------------|-----|--------------------------------|--------------------|------|---------------------------|-------------|
| | Min | Typ ⁽¹⁾ | Max | Min | Typ ⁽¹⁾ | Max | | |
| $T_J = -40^{\circ}C$ | 1 | 3.2 | 5 | -5 | -3.2 | -1 | -1100 | South Pole |
| $T_J = 25^{\circ}C$ | 1 | 3 | 5 | -5 | -3.0 | -1 | | |
| $T_J = 150^{\circ}C$ | 0.5 | 2.6 | 5 | -5 | -2.6 | -0.5 | | |

¹ Typical values are defined at $T_A = +25^{\circ}C$ and $V_{DD} = 12V$

6.5. MLX92215LSE-AEA-000

DC Operating Parameters $V_{DD} = 3.8$ to $24V$, $T_A = -40^{\circ}C$ to $150^{\circ}C$

| Test Condition | Operating Point B_{OP} (mT) | | | Release Point B_{RP} (mT) | | | TC (ppm/ $^{\circ}C$) | Active Pole |
|----------------------|----------------------------------|--------------------|-----|--------------------------------|--------------------|------|---------------------------|-------------|
| | Min | Typ ⁽¹⁾ | Max | Min | Typ ⁽¹⁾ | Max | Typ ⁽¹⁾ | |
| $T_J = -40^{\circ}C$ | 1 | 3.2 | 5 | -5 | -3.2 | -1 | -1100 | South Pole |
| $T_J = 25^{\circ}C$ | 1 | 3 | 5 | -5 | -3.0 | -1 | | |
| $T_J = 150^{\circ}C$ | 0.5 | 2.6 | 5 | -5 | -2.6 | -0.5 | | |

Note: $TC = \frac{B_{T_2} - B_{T_1}}{B_{25^{\circ}C} \times (T_2 - T_1)} \times 10^6, \left[\frac{ppm}{^{\circ}C} \right]; T_1 = -40^{\circ}C; T_2 = 150^{\circ}C$

¹ Typical values are defined at $T_A = +25^{\circ}C$ and $V_{DD} = 12V$

7. Output Behavior versus Magnetic Pole

Output behaviour versus magnetic pole ⁽¹⁾

7.1. South Pole Active

DC Operating Parameters $T_A = -40^{\circ}\text{C}$ to 150°C , $V_{DD} = 2.7\text{V}$ to 24V

| Parameter | Test Conditions | OUT |
|------------|-----------------|----------------------------------|
| South pole | $B > B_{OP}$ | Low (V_{DSon}) |
| North pole | $B < B_{RP}$ | High (V_{PU}) ⁽²⁾ |

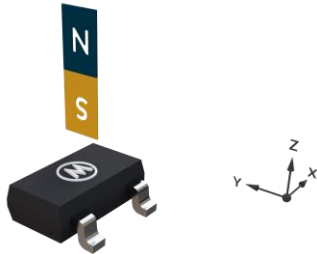

7.2. North Pole Active

DC Operating Parameters $T_A = -40^{\circ}\text{C}$ to 150°C , $V_{DD} = 2.7\text{V}$ to 24V

| Parameter | Test Conditions | OUT |
|------------|-----------------|----------------------------------|
| South pole | $B > B_{OP}$ | High (V_{PU}) ⁽²⁾ |
| North pole | $B < B_{RP}$ | Low (V_{DSon}) |

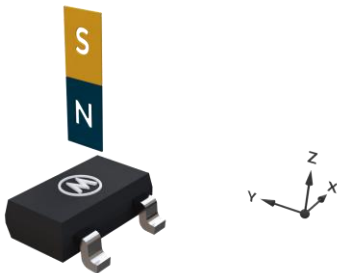

¹ Magnetic pole facing the branded/top side of the package

² Default Output state during power-up

8. Performance Graphs

8.1. Magnetic parameters vs. T_A

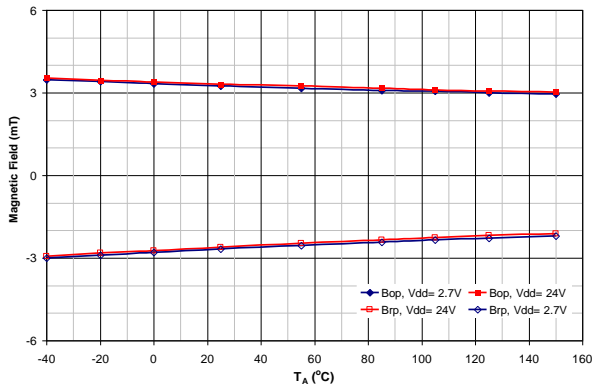

8.2. Magnetic parameters vs. V_{DD}

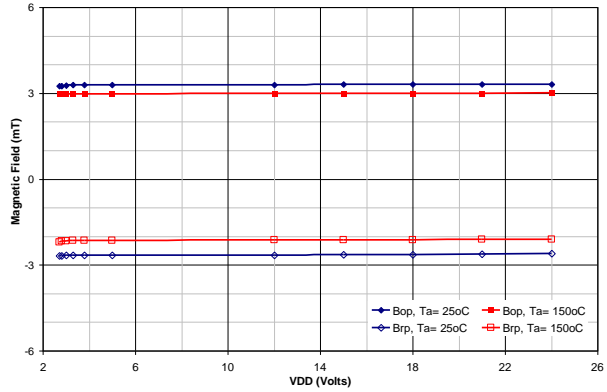

8.3. V_{Dson} vs. T_A

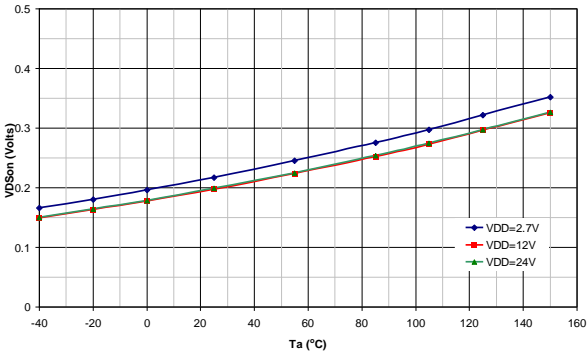

8.4. V_{Dson} vs. V_{DD}

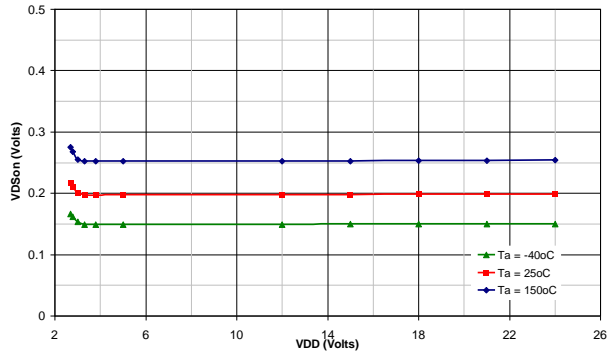

8.5. I_{DD} vs. T_A

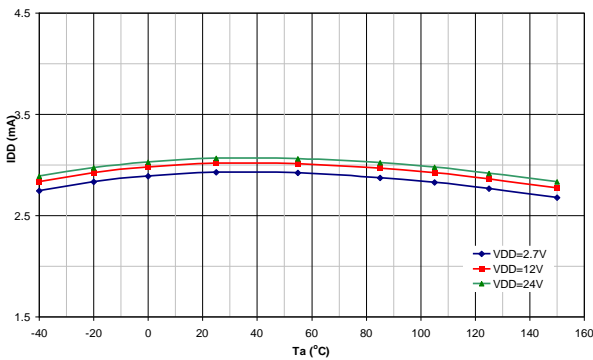

8.6. I_{DD} vs. V_{DD}

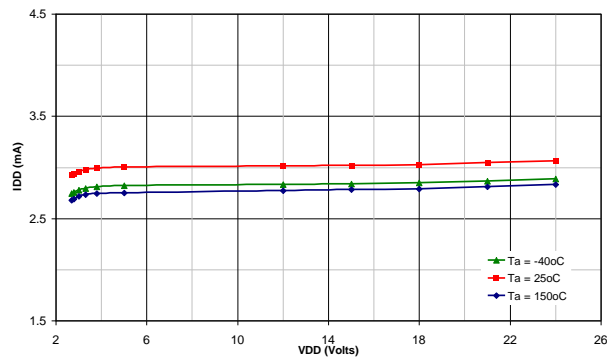

8.7. I_{OFF} vs. T_A

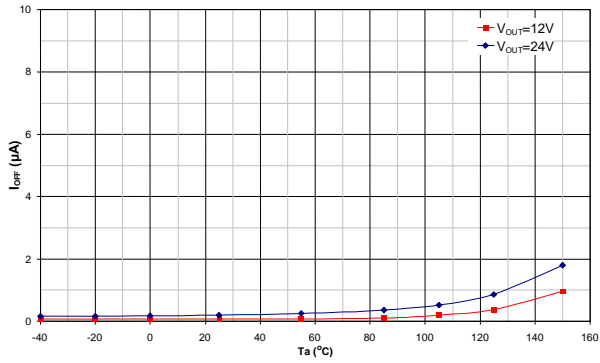

8.8. I_{OFF} vs. V_{OUT}

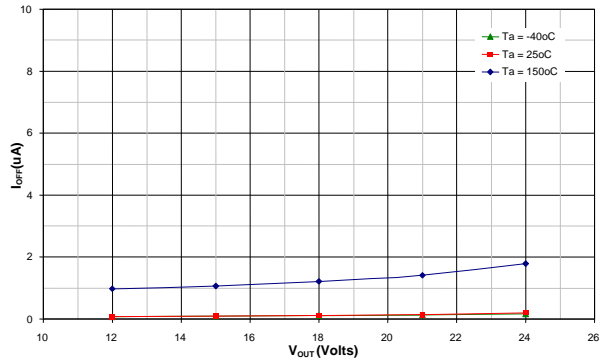

8.9. SE Power Derating vs. T_A

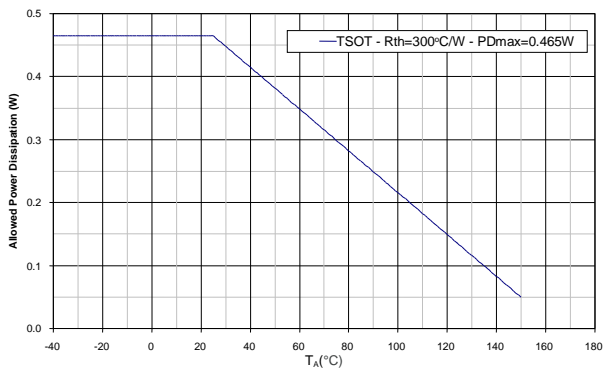

8.10. UA Power Derating vs. T_A

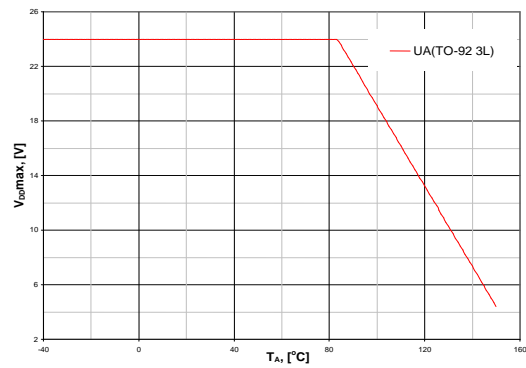

9. Application Information

9.1. Typical Three-Wire Application Circuit

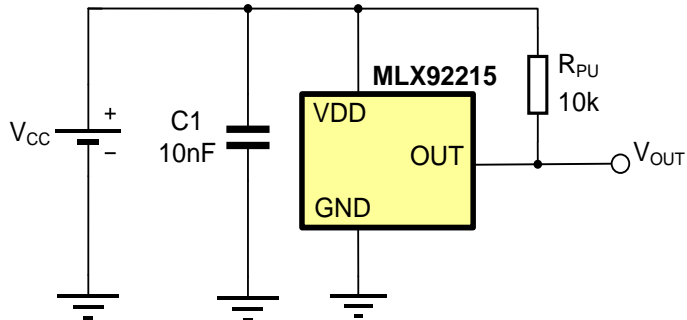

Notes:

1. For proper operation, a 10nF to 100nF bypass capacitor should be placed as close as possible to the V_{DD} and ground pin.
2. The pull-up resistor R_{PU} value should be chosen in to limit the current through the output pin below the maximum allowed continuous current for the device.
3. A capacitor connected to the output is not obligatory, because the output slope is generated internally.

10. Standard information regarding manufacturability of Melexis products with different soldering processes

Our products are classified and qualified regarding soldering technology, solderability and moisture sensitivity level according to following test methods:

Reflow Soldering SMD's (Surface Mount Device)s

- IPC/JEDEC J-STD-020
Moisture/Reflow Sensitivity Classification for Nonhermetic Solid State Surface Mount Devices (classification reflow profiles according to table 5-2)
- EIA/JEDEC JESD22-A113
Preconditioning of Nonhermetic Surface Mount Devices Prior to Reliability Testing (reflow profiles according to table 2)

Wave Soldering SMD's (Surface Mount Device)s and THD's (Through Hole Device)s

- EN60749-20
Resistance of plastic- encapsulated SMD's to combined effect of moisture and soldering heat
- EIA/JEDEC JESD22-B106 and EN60749-15
Resistance to soldering temperature for through-hole mounted devices

Iron Soldering THD's (Through Hole Device)s

- EN60749-15
Resistance to soldering temperature for through-hole mounted devices

Solderability SMD's (Surface Mount Device)s and THD's (Through Hole Device)s

- EIA/JEDEC JESD22-B102 and EN60749-21
Solderability

For all soldering technologies deviating from above mentioned standard conditions (regarding peak temperature, temperature gradient, temperature profile etc) additional classification and qualification tests have to be agreed upon with Melexis.

The application of Wave Soldering for SMD's is allowed only after consulting Melexis regarding assurance of adhesive strength between device and board.

Melexis is contributing to global environmental conservation by promoting **lead free** solutions. For more information on qualifications of **RoHS** compliant products (RoHS = European directive on the Restriction Of the use of certain Hazardous Substances) please visit the quality page on our website: <http://www.melexis.com/quality.aspx>

11. ESD Precautions

Electronic semiconductor products are sensitive to Electro Static Discharge (ESD). Always observe Electro Static Discharge control procedures whenever handling semiconductor products.

12. Packages

12.1. SE Package (TSOT-23) package information

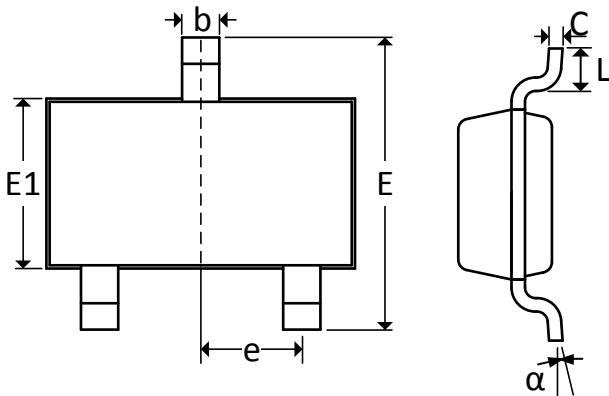

Notes:

1. All dimensions are in millimeters
2. Outermost plastic extreme width does not include mold flash or protrusions. Mold flash and protrusions shall not exceed 0.15mm per side.
3. Outermost plastic extreme length does not include mold flash or protrusions. Mold flash and protrusions shall not exceed 0.25mm per side.
4. The lead width dimension does not include dambar protrusion. Allowable dambar protrusion shall be 0.07mm total in excess of the lead width dimension at maximum material condition.
5. Dimension is the length of terminal for soldering to a substrate.
6. Formed lead shall be planar with respect to one another with 0.076mm at seating plane.

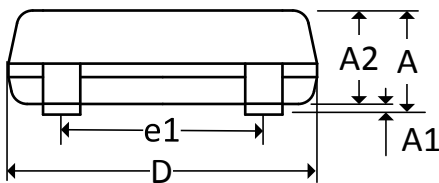

Marking:

Top side :

AAA/AEA: 15YY; YY: Year (last 2 digits)

ACA: 15CY; Y: Year

Bottom side:

AAA/AEA: XXXX: Lot Number (last 4 digits)

ACA: XXXX: 3rd up to 6th characters of the Lot Number

Hall plate location

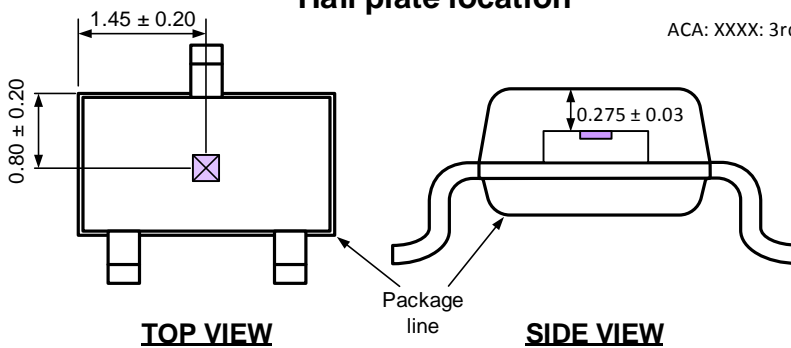

| | A | A1 | A2 | D | E | E1 | L | b | c | e | e1 | α |
|-----|------|-------|------|------|------|------|------|------|------|------|------|----------|
| min | – | 0.025 | 0.85 | 2.80 | 2.60 | 1.50 | 0.30 | 0.30 | 0.10 | 0.95 | 1.90 | 0° |
| max | 1.00 | 0.10 | 0.90 | 3.00 | 3.00 | 1.70 | 0.50 | 0.45 | 0.20 | BSC | BSC | 8° |

| UA Pin № | Name | Type | Function |
|----------|------|--------|--------------------|
| 1 | VDD | Supply | Supply Voltage pin |
| 2 | OUT | Output | Open drain output |
| 3 | GND | Ground | Ground pin |

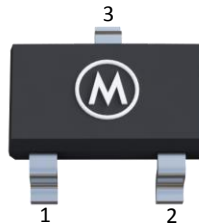

1.1 UA (TO92 - 3L) package information

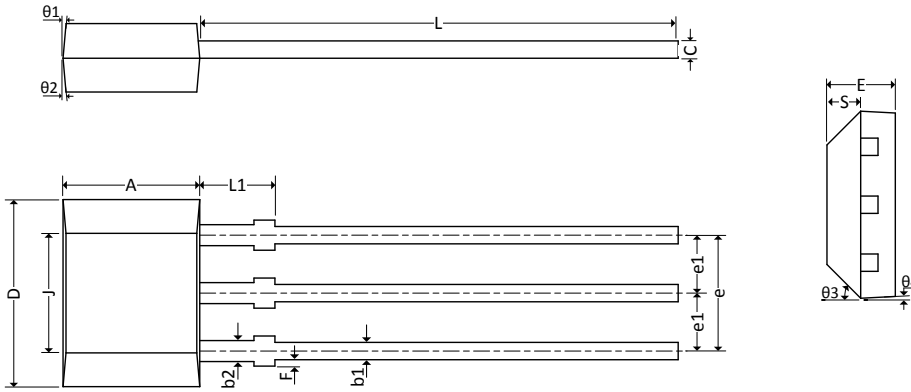

Hall plate location

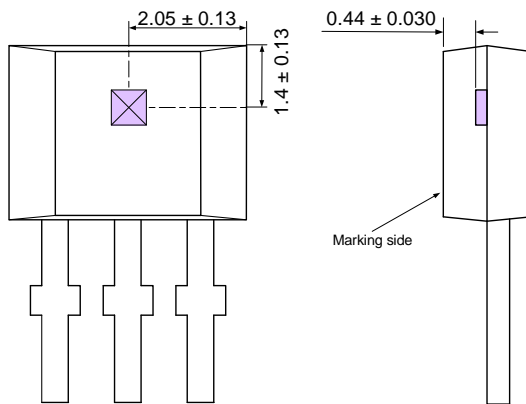

Notes

1. All dimensions are in millimeters
2. Package dimension exclusive molding flash
3. The end flash shall not exceed 0.127mm on the top side

Marking:

- Line1:
15EY; Y - last digit of year
Line2:
LLLL- last four digits from lot number

| | A | D | E | F | J | L | L1 | S | b1 | b2 | c | e | e1 |
|-----|------|------|------|------|------|------|------|------|------|------|------|------|------|
| min | 2.80 | 3.90 | 1.40 | 0.00 | 2.51 | 14.0 | 0.90 | 0.63 | 0.35 | 0.43 | 0.35 | 2.51 | 1.24 |
| max | 3.20 | 4.30 | 1.60 | 0.15 | 2.72 | 15.0 | 1.10 | 0.84 | 0.44 | 0.52 | 0.44 | 2.57 | 1.30 |

| | theta1 | theta2 | theta3 | theta4 |
|-----|--------|--------|--------|--------|
| Min | 7° | 7° | 45° | 7° |
| max | REF | REF | REF | REF |



| UA Pin № | Name | Type | Function |
|----------|------|--------|--------------------|
| 1 | VDD | Supply | Supply Voltage pin |
| 2 | GND | Ground | Ground pin |
| 3 | OUT | Output | Open drain output |

13. Contact

For the latest version of this document, go to our website at www.melexis.com.

For additional information, please contact our Direct Sales team and get help for your specific needs:

| | |
|----------------|----------------------------------|
| Europe, Africa | Telephone: +32 13 67 04 95 |
| | Email : sales_europe@melexis.com |
| Americas | Telephone: +1 603 223 2362 |
| | Email : sales_usa@melexis.com |
| Asia | Email : sales_asia@melexis.com |

14. Disclaimer

The information furnished by Melexis herein ("Information") is believed to be correct and accurate. Melexis disclaims (i) any and all liability in connection with or arising out of the furnishing, performance or use of the technical data or use of the product(s) as described herein ("Product") (ii) any and all liability, including without limitation, special, consequential or incidental damages, and (iii) any and all warranties, express, statutory, implied, or by description, including warranties of fitness for particular purpose, non-infringement and merchantability. No obligation or liability shall arise or flow out of Melexis' rendering of technical or other services.

The Information is provided "as is" and Melexis reserves the right to change the Information at any time and without notice. Therefore, before placing orders and/or prior to designing the Product into a system, users or any third party should obtain the latest version of the relevant information to verify that the information being relied upon is current. Users or any third party must further determine the suitability of the Product for its application, including the level of reliability required and determine whether it is fit for a particular purpose.

The Information is proprietary and/or confidential information of Melexis and the use thereof or anything described by the Information does not grant, explicitly or implicitly, to any party any patent rights, licenses, or any other intellectual property rights.

This document as well as the Product(s) may be subject to export control regulations. Please be aware that export might require a prior authorization from competent authorities.

The Product(s) are intended for use in normal commercial applications. Unless otherwise agreed upon in writing, the Product(s) are not designed, authorized or warranted to be suitable in applications requiring extended temperature range and/or unusual environmental requirements. High reliability applications, such as medical life-support or life-sustaining equipment are specifically not recommended by Melexis.

The Product(s) may not be used for the following applications subject to export control regulations: the development, production, processing, operation, maintenance, storage, recognition or proliferation of 1) chemical, biological or nuclear weapons, or for the development, production, maintenance or storage of missiles for such weapons; 2) civil firearms, including spare parts or ammunition for such arms; 3) defense related products, or other material for military use or for law enforcement; 4) any applications that, alone or in combination with other goods, substances or organisms could cause serious harm to persons or goods and that can be used as a means of violence in an armed conflict or any similar violent situation.

The Products sold by Melexis are subject to the terms and conditions as specified in the Terms of Sale, which can be found at <https://www.melexis.com/en/legal/terms-and-conditions>.

This document supersedes and replaces all prior information regarding the Product(s) and/or previous versions of this document.

Melexis NV © - No part of this document may be reproduced without the prior written consent of Melexis. (2016)

ISO/TS 16949 and ISO14001 Certified