

THIS DOCUMENT IS THE PROPERTY OF KEYSTONE ELECTRONICS CORP. AND SHALL NOT BE REPRODUCED, DISTRIBUTED OR USED AS A BASIS FOR MANUFACTURE WITHOUT PRIOR WRITTEN PERMISSION FROM KEYSTONE ELECTRONICS CORP.

MOUNTING LAYOUT

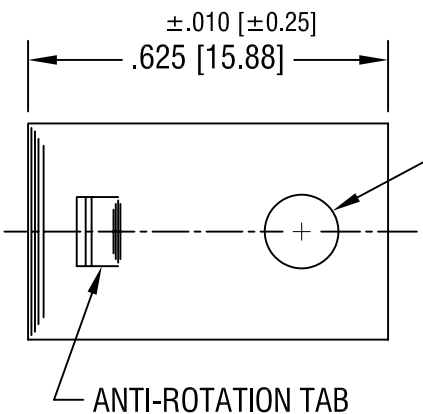
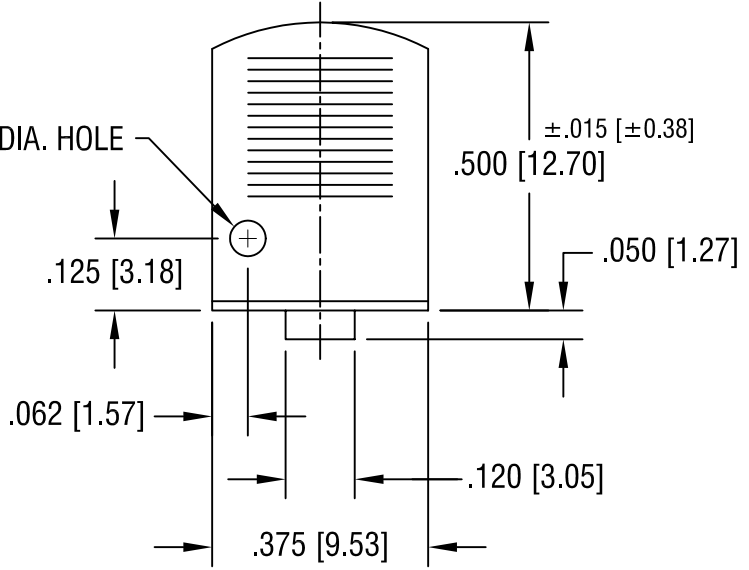
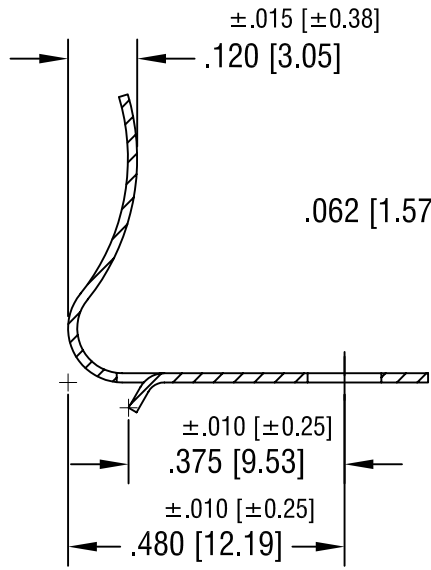
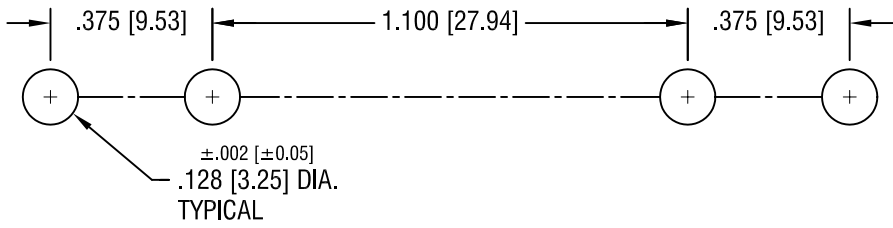

NOTE:
1. HEAT TREAT TO SPRING TEMPER.

KEYSTONE ELECTRONICS CORP.			
ASTORIA, N.Y. 11105-2017			
PART NAME		'AA' BATTERY CLIP	
MATERIAL			
.016 [.40] TH'K ANNEALED SPRING STEEL			
FINISH		DRN BY	DATE
NICKEL PLATE		BOONE	1.29.82
		APPD	SCALE
		LN	3X
TOLERANCES	INCH	[MM]	CODE
DECIMAL	±.005	[±0.15]	C
ANGULAR	± 1°		
UNLESS OTHERWISE SPECIFIED			DWG NO.
			206

4.23.01	CHANGE AS PER ECN 01-027	E
DATE	DESCRIPTION	REV.