

THIS DOCUMENT IS THE PROPERTY OF  
 KEYSTONE ELECTRONICS CORP. AND  
 SHALL NOT BE REPRODUCED, DISTRIBUTED  
 OR USED AS A BASIS FOR MANUFACTURE  
 WITHOUT PRIOR WRITTEN PERMISSION  
 FROM KEYSTONE ELECTRONICS CORP.

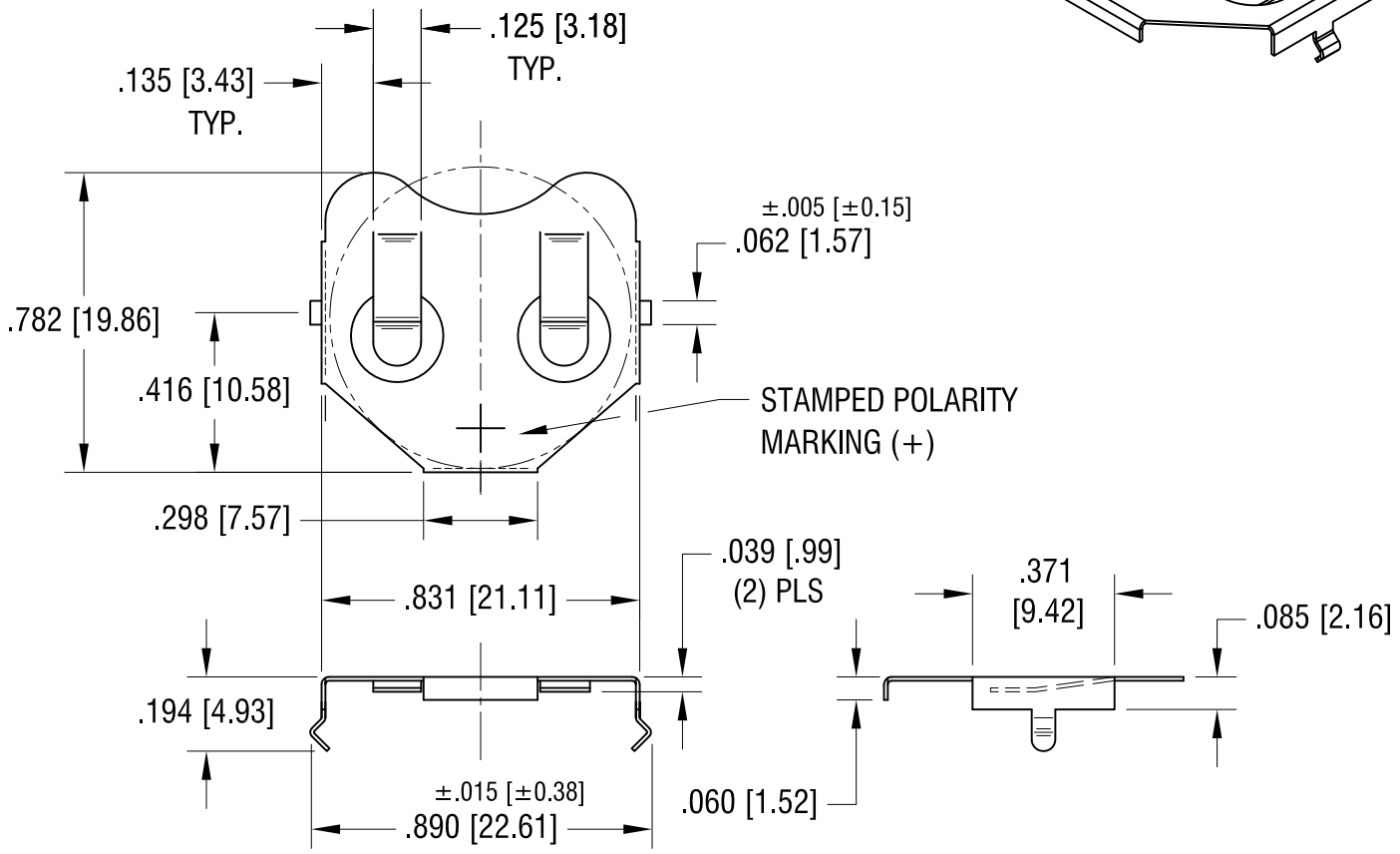
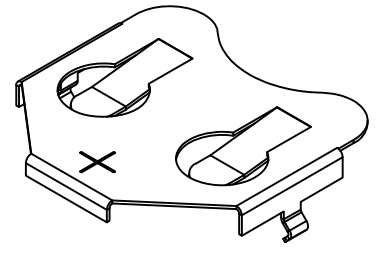
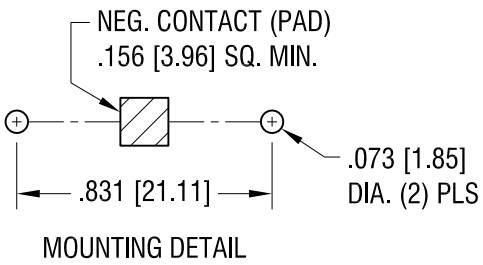

<b>KEYSTONE ELECTRONICS CORP.</b>			
ASTORIA, N.Y. 11105-2017			
PART NAME		20mm PC COIN CELL CLIP	
MATERIAL		.010 [0.25] TH'K PHOSPHOR BRONZE	
FINISH	TIN NICKEL PLATE	DRN BY HAMILTON	DATE 5JUN09
		APP'D LN	SCALE 2X
TOLERANCES	INCH [MM]	CODE	DWG NO.
DECIMAL	±.010 [±0.25]	C	3027
ANGULAR	± 1°		
UNLESS OTHERWISE SPECIFIED			

DATE	DESCRIPTION	REV.