

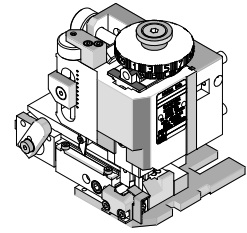

**FineAdjust  
Applicator**

**Application Tooling  
Specification Sheet**



**Order No. 63900-1300**

**FEATURES**

- Quick punch removal with the push of a button for fast and easy tooling change
- Applicator designed to industry standard mounting and shut height 135.80mm (5.346")
- Quick set-up time; plus the crimp height, track and feed adjustments can be set without removing the applicator from the press
- Fine adjustment allows users to achieve target with little effort by adjusting in increments of .015mm (.0006") for conductor crimp height and .063mm (.0025") for insulation height
- Independent adjustment rings allow users to quickly adjust the conductor or insulation crimp height without affecting each other
- Directly adapts to most automatic wire processing machines

**SCOPE**

Products: Micro-Fit 3.0™ Low Force Female Crimp Terminal 26-30 AWG.

Terminal Series No.	Terminal Order No.		Wire Size		✗ Insulation Diameter		Strip Length	
			AWG	mm <sup>2</sup>	mm	In.	mm	In.
46235	46235-0003	46235-0004	26-30	0.13-0.05	1.12-1.27	.044-.050	2.54-2.92	.100-.115
	46235-5003	46235-5004						

✗ Note: 1. Insulation OD range: 1.20-1.27mm will provide optimum A-620-Class 2 crimps.  
2. Insulation OD range: 1.12-1.17mm will not provide optimum A-620 crimps.

**DEFINITION OF TERMS**

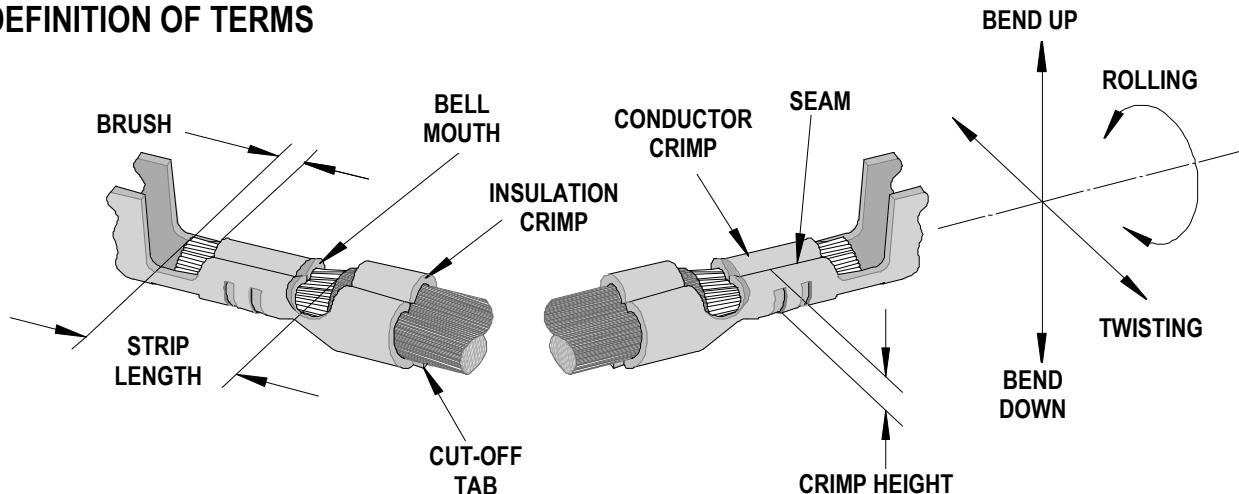

The above terminal drawing is a generic terminal representation. It is not an image of a terminal listed in the scope.

### CRIMP SPECIFICATION

Terminal Series No.	Bell mouth		Cut-off Tab Maximum		Conductor Brush	
	mm	In.	mm	In.	mm	In.
46235	0.05-0.40	.002-.016	0.25	.010	0.20-0.80	.008-.031

Terminal Series No.	Bend up	Bend down	Twist	Roll	Punch Width (Ref)				Seam Seam shall not be open And no wire allowed out of the crimping area
					Conductor		Insulation		
	Degree		Degree		mm	In.	mm	In.	
46235	3	3	4	8	1.00	.039	1.60	.063	

After crimping, the crimp profiles should measure the following:

Terminal Series No.	Wire Size		Conductor				Pull Force Minimum	
			Crimp Height		Crimp Width (Ref)			
	AWG	mm <sup>2</sup>	mm	In.	mm	In.	N	Lb.
46235	26	0.13	0.51-0.56	.020-.022	1.05	.041	13.4	3.0
	28	0.08	0.48-0.53	.019-.021	1.05	.041	8.9	2.0
	30	0.05	0.45-0.50	.018-.020	1.05	.041	6.7	1.5

**\* Tool Qualification Notes:**

1. Pull Force should be measured with no influence from the insulation crimp.
2. The above specifications are guidelines to an optimum crimp.

**PARTS LIST**

<b>FineAdjust Applicator 63900-1300</b>				
<b>Item</b>	<b>Order No</b>	<b>Engineering No.</b>	<b>Description</b>	<b>Quantity</b>
<b>Perishable Tooling</b>				
	63900-1370	63900-1370	Tool Kit (All "Y" Items)	REF
1	63457-0038	63457-0038	Conductor Punch	1 Y
2	63455-0048	63455-0048	Conductor Anvil	1 Y
3	63446-1610	63446-1610	Insulation Punch	1 Y
4	63445-1619	63445-1619	Insulation Anvil	1 Y
5	63443-0005	63443-0005	Cut-Off Plunger Front	1 Y
6	63443-0012	63443-0012	Plunger Retainer Front	1 Y
<b>Other Components</b>				
7	11-18-4083	60707-8	Feed Guide	1
8	11-24-1067	4996-4	Cut-Off Plunger Spring	1
9	63443-0009	63443-0009	Front Scrap Chute	1
10	63443-0025	63443-0025	Key	1
11	63443-0090	63443-0090	Wire Stop	1
12	63443-1716	63443-1716	Height Spacer	1
13	63443-2216	63443-2216	Coarse Spacer (16.00mm)	1
14	63443-2307	63443-2307	Fine Spacer (3.35mm)	1
15	63443-2802	63443-2802	Plunger Striker	1
16	63443-2903	63443-2903	Hold Down Plunger	1
17	63443-6109	63443-6109	Rear Cover	1
18	63600-0021	63600-0021	Compression Spring	1
<b>Frame</b>				
19	63800-4901	63800-4901	Top	1
20	63801-3281	63801-3281	Base	1
21	63801-4650	63801-4650	Track	1
<b>Hardware</b>				
22	N/A	N/A	M3 by 6 Long SHCS	2**
23	N/A	N/A	M3 by 6 Long FHCS	1**
24	N/A	N/A	M4 by 6 Long SHCS	2**
25	N/A	N/A	M4 by 12 Long BHCS	2**
26	N/A	N/A	M4 by 50 Long SHCS	2**
27	N/A	N/A	M5 by 12 Lg SHCS	1**
28	N/A	N/A	#10-32 by 3/8" Long Flat Point SSS	1**
29	N/A	N/A	#10-32 Hex Jam Nut	1**

\*\* Available from an industrial supply company such as MSC (1-800-645-7270).

### Assembly Drawing

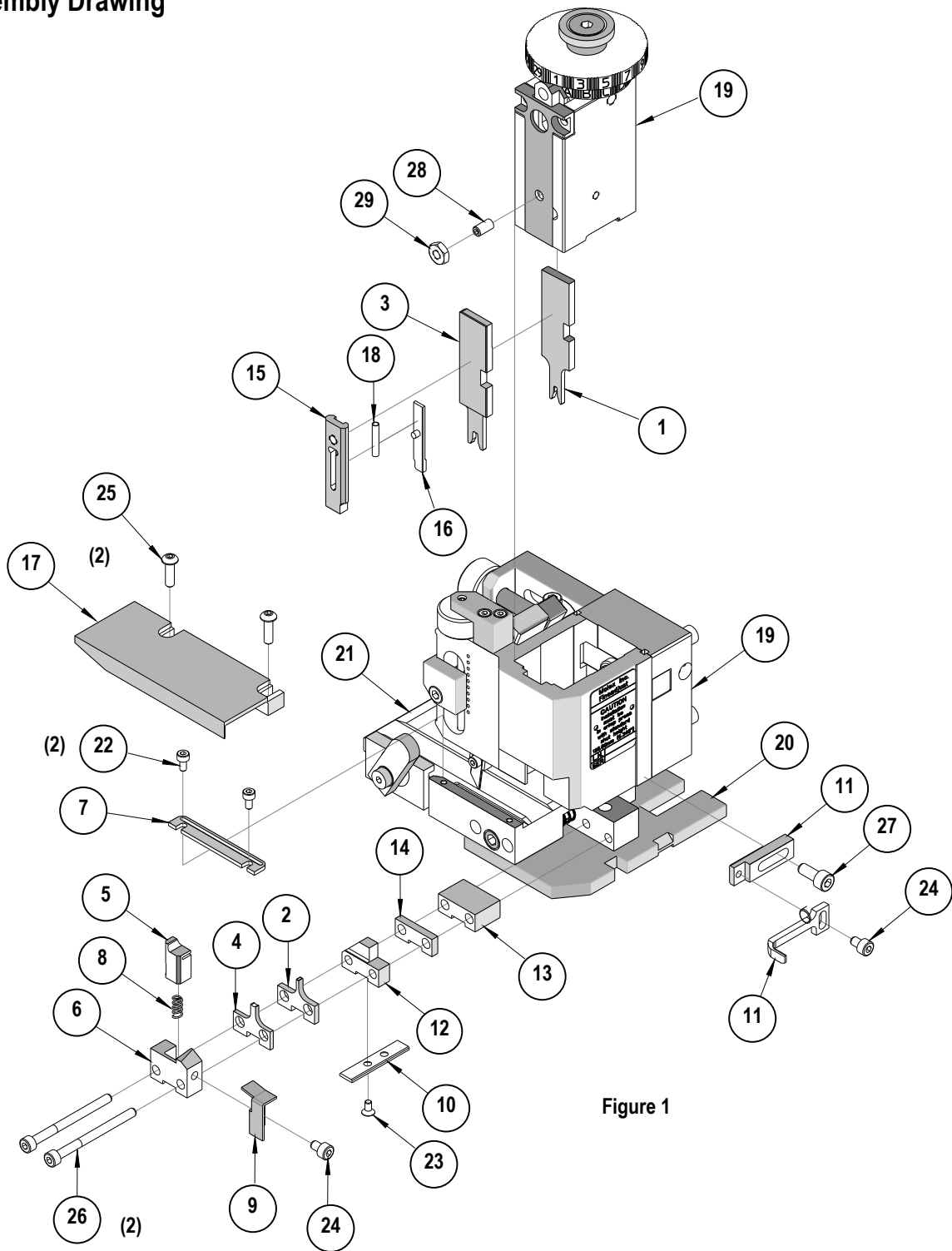

Figure 1

## NOTES

1. Molex recommends an extra perishable tooling kit be maintained at your facility.
2. Verify tooling alignment by manually cycling the press and Applicator before crimping under power. Check that all screws are tight.
3. Slugs, Terminals, Dirt and Oil should be kept clear of work area.
4. Wear safety glasses at all times.
5. For recommended maintenance refer to the FineAdjust Manual.

**CAUTION:** This applicator should only be used in a press with a shut height of 135.80 mm (5.346"). Tooling damage could result at a lower setting.

**CAUTION:** To prevent injury never operate this Applicator without the guards supplied with the press or wire-processing machine in place. Reference the press or wire processing manufacturer's instruction manual.

**CAUTION:** Molex crimp specifications are valid only when used with Molex terminals, applicators and tooling.

<http://www.molex.com>