

| SPECIFICATIONS                  |                                      |
|---------------------------------|--------------------------------------|
| RATING                          | .4VA MAX. @ 20VDC, OR PEAK AC        |
| TIMING                          | BREAK BEFORE MAKE                    |
| INITIAL CONTACT RESISTANCE      | 30 MILLIOHMS MAX                     |
| INSULATION RESISTANCE           | 10,000 MEGOHMS MIN                   |
| DIELECTRIC WITHSTANDING VOLTAGE | 1,000 VRMS AT SEA LEVEL              |
| DURABILITY                      | 10,000 CYCLES @ .4VA RESISTIVE       |
|                                 | 30,000 CYCLES @ .1μA 12VDC RESISTIVE |
| OPERATING FORCE                 | 14 INCH OUNCES                       |
| OPERATING TEMPERATURE           | -20°C TO +70°C                       |
| STORAGE TEMPERATURE             | -20°C TO +70°C                       |

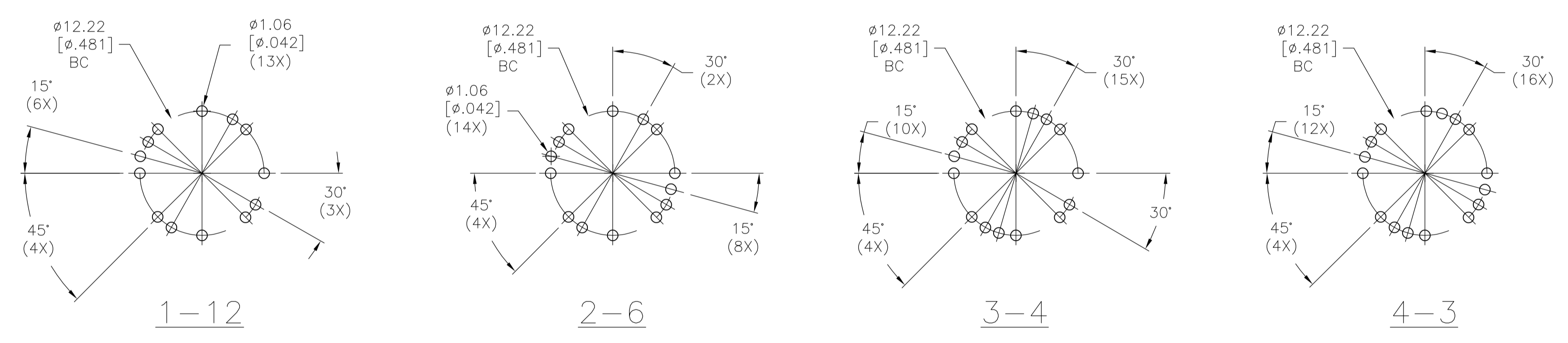

RECOMMENDED PCB HOLE LAYOUTS (VIEWED FROM SHAFT END)  
TOLERANCE ±.002. UNLESS OTHERWISE NOTED.

NOTES:

1. TERMINAL NUMBERS ARE FOR REFERENCE ONLY AND DO NOT APPEAR ON SWITCHES.
2. ALL MATERIALS AND FINISHES SHALL COMPLY WITH EU DIRECTIVE 2002/95/EC OF 27JAN2003 (ROHS).
3. EACH SWITCH SUPPLIED WITH THE FOLLOWING MOUNTING HARDWARE:  
(2) HEX NUTS.  
(1) LOCKING RING FOR ANTIROTATION.  
(1) INTERNAL TOOTH LOCKWASHER.

| MATERIALS                 |                 |                  |
|---------------------------|-----------------|------------------|
| COMPONENT NAME            | BASE MATERIAL   | FINISH           |
| BASE                      | EPOXY           | -                |
| FIXED CONTACT             | BRASS           | GOLD OVER NICKEL |
| TERMINAL                  | BRASS           | TIN OVER NICKEL  |
| MOVEABLE CONTACT          | PHOSPHOR BRONZE | GOLD OVER NICKEL |
| ROTOR                     | PBT             | -                |
| BALL                      | STEEL           | -                |
| SPRING                    | PIANO WIRE      | -                |
| STOPPER                   | STEEL           | ZINC             |
| BUSHING                   | ZINC            | NICKEL           |
| SHAFT                     | BRASS           | NICKEL           |
| LOCKING RING              | STEEL           | ZINC             |
| HEX NUT                   | BRASS           | NICKEL           |
| INTERNAL TOOTH LOCKWASHER | STEEL           | ZINC             |

|                  |                 |              |          |             |
|------------------|-----------------|--------------|----------|-------------|
| 9 [.35]          | 3~4 ADJUSTABLE  | 3            | MRJ34904 | 1825535-5   |
| 19 [.75]         | 4~3 ADJUSTABLE  | 4            | MRJ4304  | 1825535-4   |
| 19 [.75]         | 3~4 ADJUSTABLE  | 3            | MRJ3404  | 1825535-3   |
| 19 [.75]         | 2~6 ADJUSTABLE  | 2            | MRJ2604  | 1825535-2   |
| 19 [.75]         | 1~12 ADJUSTABLE | 1            | MRJ11204 | 1825535-1   |
| "A" SHAFT LENGTH | POSITIONS       | NO. OF POLES | ALCO P/N | PART NUMBER |

|  |  |                           |                                 |         |
|--|--|---------------------------|---------------------------------|---------|
| THIS DRAWING IS A CONTROLLED DOCUMENT. |  | DIN                       | REV B ED                        | DAMAYB3 |
| DIMENSIONS: mm [INCHES]                |  | CIK                       | -                               | -       |
| TOLERANCES UNLESS OTHERWISE SPECIFIED: |  | APVD                      | -                               | -       |
| 0 PLC ± -                              |  | NAME                      | MINIATURE ROTARY SWITCH         |         |
| 1 PLC ± 5.08 [.2]                      |  | PRODUCT SPEC              | 12 POS.-30° DETENT (MRJ SERIES) |         |
| 2 PLC ± 2.54 [.1]                      |  | APPLICATION SPEC          | -                               |         |
| 3 PLC ± -                              |  | SIZE                      | A1                              | 00779   |
| 4 PLC ± -                              |  | WEIGHT                    | 1825535                         |         |
| ANGLES ± ± 1°                          |  | CUSTOMER DRAWING          | SCALE                           | 3:1     |
| MATERIAL SEE SPECIFICATIONS            |  | FINISH SEE SPECIFICATIONS | SHEET                           | 1 OF 1  |
|  |  | RESTRICTED TO             | REV                             | A4      |