

# Intrinsically safe certified accelerometer

## 780A-IS

### SPECIFICATIONS

<b>Sensitivity, ±5%, 25°C</b>		100 mV/g
<b>Acceleration range</b>		80 g peak
<b>Amplitude nonlinearity</b>		1%
<b>Frequency response:</b>	<b>±5%</b>	1 - 7,000 Hz
	<b>±10%</b>	0.7 - 9,000 Hz
	<b>±3 dB</b>	0.4 - 14,000 Hz
<b>Resonance frequency</b>		30 kHz
<b>Transverse sensitivity, max</b>		5% of axial
<b>Temperature response:</b>	<b>-55°C</b>	-20%
	<b>+120°C</b>	+10%
<b>Power requirement:</b>	<b>Voltage source</b>	18 - 30 VDC
	<b>Current regulating diode</b>	2 - 10 mA
<b>Electrical noise, equiv. g:</b>		
<b>Broadband</b>	<b>2.5 Hz to 25 kHz</b>	500 µg
<b>Spectral</b>	<b>10 Hz</b>	7 µg/√Hz
	<b>100 Hz</b>	4 µg/√Hz
	<b>1,000 Hz</b>	2 µg/√Hz
<b>Output impedance, max</b>		100 Ω
<b>Bias output voltage</b>		12 VDC
<b>Grounding</b>		case isolated, internally shielded
<b>Temperature range</b>		-55° to +120°C
<b>Vibration limit</b>		500 g peak
<b>Shock limit</b>		5,000 g peak
<b>Electromagnetic sensitivity, equiv. g, max</b>		70 µg/gauss
<b>Sealing</b>		hermetic
<b>Base strain sensitivity, max</b>		0.0002 g/µstrain
<b>Sensing element design</b>		PZT, shear
<b>Weight</b>		62 grams
<b>Case material</b>		316L stainless steel
<b>Mounting</b>		1/4-28 UNF tapped hole
<b>Output connector</b>		2 pin, MIL-C-5015 style
<b>Mating connector</b>		R6 type
<b>Recommended cabling</b>		J10 / J9T2A

**Note:** Frequency response and spectral noise values are typical.

**Accessories supplied:** SF6 mounting stud; calibration data (level 2)

**Optional accessories available:** ISBS-STD-08: MTL 7728 + safety barrier

### Certifications

	Class I, Div 1 Groups A, B, C, D		II 1 G	
	Class II, Div 1 Groups E, F, G		Ex ia IIC T4 Ga	
	Class III		Ta = -50°C to 120°C	
	Class I Zone 0 AEx/Ex ia IIC T4			
Ta = -50°C to 120°C				

Must be installed per document 12879. For application in explosive atmospheres caused by gases, vapours or mists and where the use of apparatus of category 1G is required, electrostatic charges on the cable and non-metallic parts of the enclosure shall be avoided. The ambient temperature range for these applications is -40°C to +80°C.



### Key features

- Compact size
- Hazardous area certified - intrinsically safe
- API 670 compliant
- Manufactured in ISO 9001 facility

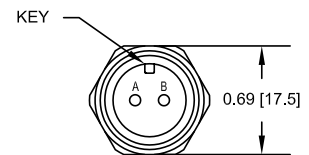
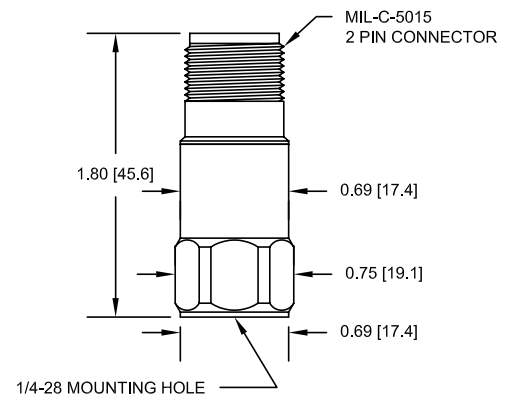

Connections	
Function	Connector pin
power/signal	A
common	B
ground	shell

**Note:** Due to continuous process improvement, specifications are subject to change without notice. This document is cleared for public release.