



**PART NO. : TG32-3506NDRL**

16PIN SMT ISOLATION MODULE FOR 10/100BASE-TX  
IEEE802.3u APPLICATIONS

LEAD-FREE/RoHS COMPLIANT

COMPATIBLE TO LEAD-FREE SOLDERING PROCESS  
CONDITION PER IPC/JEDEC J-STD-020C

OPERATING TEMPERATURE 0/+70°C

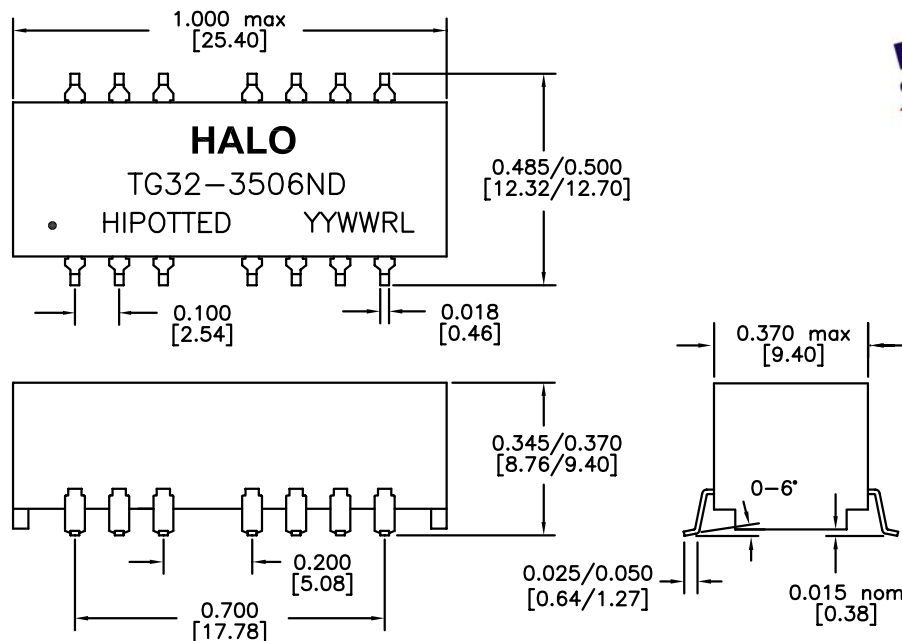

DIMENSIONS: Inch[mm]  
CO-PLANARITY: 0.004[0.10]  
TOLERANCES: ±0.005 INCH IF NOT SPECIFIED

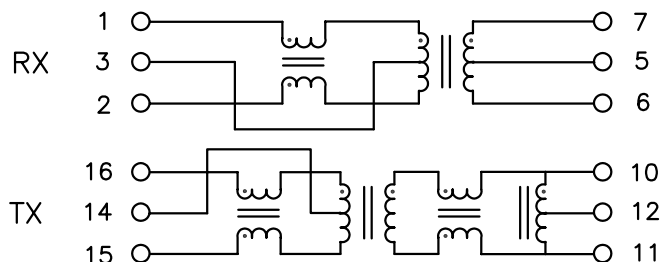

**ELECTRICAL SPECIFICATIONS @25° C**

OCL (100KHz,0.1Vrms,8mA)	350µH min
TURN RATIO	
TX P16-15:P10-11	1CT:1CT ±3%
RX P1-2:P7-6	1CT:1CT ±3%
DCR P16-15,P7-6	1.0Ω max
LL (1MHz)	0.4µH max
Cw/w	15pF typ
INSERTION LOSS	
0.1-100MHz	-1.1dB max
RETURN LOSS	
0.5-30MHz	-18dB min
40MHz	-15.5dB min
50MHz	-13.6dB min
60-80MHz	-12dB min
CROSSTALK 0.1-100MHz	-38dB typ
TX CMR 0.1-100MHz	-45dB typ
ISOLATION	1,500Vrms

**HALO/PBL**

CALIFORNIA, USA  
KOWLOON, HONG KONG  
SINGAPORE

TITLE	TRANSFORMER MODULE	SIGNATURES	DATE	REV.	DESC.	DATE
FOR	10/100BASE-TX	DRAWN	PETER LU	10/26/05	A	
PART NO.	TG32-3506NDRL	CHECKED				
SCALE	NONE	APPROVED				
PAGE	1 OF 2	FILE	TG32NDRL.DWG			

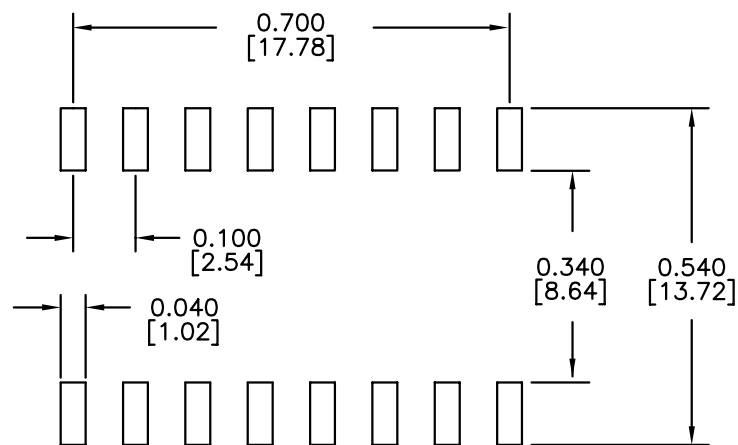

RECOMMENDED SOLDER PAD LAYOUT  
 DIMENSIONS: INCH [mm]

<b>HALO/PBL</b>	TITLE TRANSFORMER MODULE		SIGNATURES		DATE	REV.	DESC.	DATE
	FOR 10/100BASE-TX		DRAWN PETER LU		10/25/05	A		
	PART NO. TG32-3506NDRL		CHECKED					
	SCALE NONE		PAGE 2 OF 2		APPROVED			
CALIFORNIA, USA KOWLOON, HONG KONG SINGAPORE		FILE TG32NDRL.DWG						