

承 認 書
(SPECIFICATION FOR APPROVAL)

CUSTOMER : 肯創

MODEL : IG220053X00085R

DATE : Dec 29, 2014

SUPPLIER :

CUSTOMER :



祥儀企業股份有限公司
SHAYANG YE INDUSTRIAL CO.,LTD.

桃園縣桃園市桃鶯路 461 號
TEL:(03)3623452
FAX:(03)3628404
<http://www.shayye.com.tw>

NO.461, Taoying Rd., Taoyuan City,
Taoyuan County, Taiwan R.O.C.
E-MAIL:sales@shayye.com.tw

ASSEMBLY, MAINTENANCE, OPERATION

1. Install: To avoid internal geared motor touched by overlong screws and caused defective. Please check screw size and length on external dimension drawing when installing geared motor into construction.

2. Reprocess: Heavy impact and vibration during reprocessing output shaft may cause loose screws and lead to unbalance gear operation. Please avoid reprocessing output shaft. Must to prevent overheat when weld wires into terminal and cause breakdown due to burnt internal geared motor parts.
Please do not overload the radial load limitation of output shaft when using belt pulley or chain pulley as power transmission. Please do not overload the axial load limitation of output shaft when pressing parts upon it as well.

3. Environment: The parts of geared motors or itself may corroded or damaged easier when using or maintaining in out of range environment. Must to pay close attention that gears may corroded even under an allowed environment in long term.

4. Impact: Must prevent geared motor from falling and impact, or the parts will get damaged, the screws will be loosed, and the gear operation will unbalance etc...

5. Locked out: Please well prepared current transmitting protection in case of burnt motor coil easy and damaged gear from locked out geared motor.

6. Output shaft Turning:
Please note that it is easier to damage gear when directly turning output shaft.

7. PWM controlling:
The graphite brush of motor will be abnormally wore out or the commutator interval will be blocked by carbon powder when using in the condition of D/T under 60%.
Moreover, please pay attention to the motor with capacitor due to there is ineffectual capacity cycle scope.

8. Momentary reverse:
The graphite brush will be abnormally wore out or coil getting aggravated when geared motor is reversed momentary.
Also, the commutator interval will be stuck if switch frequently.

SHAYANG YE INDUSTRIAL CO.,LTD.

Mode: IG220053X00085R

S/N: 001

Voltage : 6 V

Date: 20141229

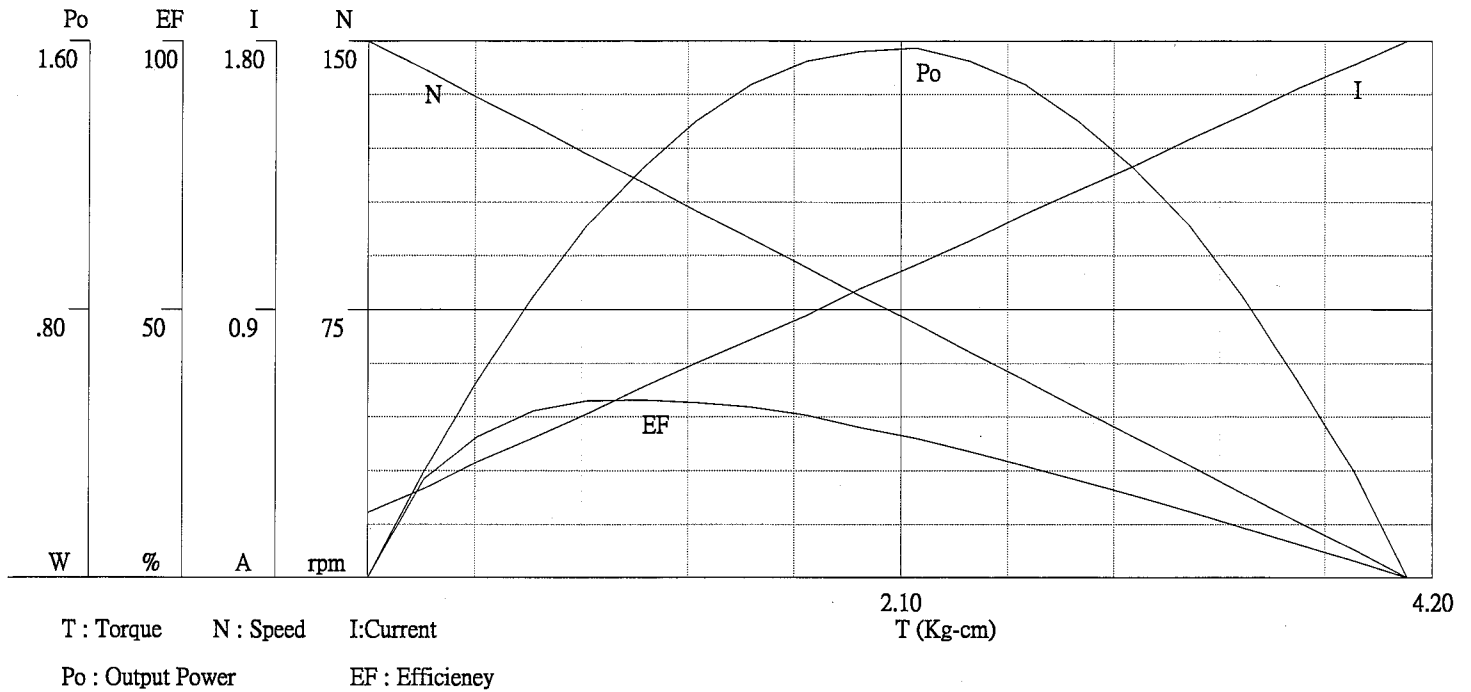

	T(N/m)	[Kg/cm]	N(rpm)	I(A)	Po(W)	EF(%)
No Load	0	0.00	150.00	.22	0	0
	.02	.22	142.04	.30	.32	18.56
	.06	.65	126.32	.47	.84	31.18
	.08	.86	118.41	.55	1.05	32.99
	.13	1.29	102.59	.72	1.36	32.75
	.15	1.51	94.82	.80	1.47	31.89
	.17	1.73	86.78	.88	1.54	30.4
	.19	1.94	78.98	.97	1.57	28.1
	.23	2.37	63.21	1.13	1.54	23.62
	.25	2.59	55.27	1.22	1.47	20.87
	.27	2.80	47.38	1.30	1.36	18.18
	.3	3.02	39.46	1.38	1.22	15.39
	.32	3.24	31.56	1.47	1.05	12.4
	.34	3.45	23.70	1.55	.84	9.4
	.38	3.89	7.90	1.72	.32	3.18
Stall	.4	4.10	0.00	1.80	0	0
Po...(max)	.21	2.16	71.09	1.05	1.58	26.06
EF...(max)	.11	1.08	110.51	.64	1.22	33.23

