





Messrs.					
Product Specification	Model	NMTC-S16208XFYHSGY-24A	Rev. No.	Issued Date.	Page.
			A	Sep. 01, 17	1 / 21

**LIQUID CRYSTAL DISPLAY MODULE**  
**MODEL: NMTC-S16208XFYHSGY-24A**  
 Customer's No.:

Acceptance

*Microtips Technology Inc.*  
*12F. No.31 Lane 169, Kang Ning St.,*  
*His-Chih, Taipei Hsien, Taiwan, R.O.C.*  
 FAX: 886-2-26958625

Approved and Checked by

Approved by	Checked by		Made by
			



*Microtips Technology Inc.*

Messrs.					
Product Specification	Model	NMTC-S16208XFYHSGY-24A	Rev. No.	Issued Date.	Page.
			<i>A</i>	<i>Sep. 01, 17</i>	<i>2 / 21</i>

### Revise Records

Rev.	Date	Contents	Written	Approved
A.	2017/09/01	See Note 1.	Jill Hus	Danny Lien

### Special Notes

Note 1.	The LCD module is compliant with RoHS.
Note 2.	
Note 3.	
Note 4.	
Note 5.	



*Microtips Technology Inc.*

Messrs.					
Product Specification	Model	NMTC-S16208XFYHSGY-24A	Rev. No.	Issued Date.	Page.
			<i>A</i>	<i>Sep. 01, 17</i>	<i>3 / 21</i>

## Contents

<b>1. General Specifications</b> .....	4
<b>2. Electrical Specifications</b> .....	5
2.1 Absolute Maximum Ratings .....	5
2.2 DC Characteristics .....	5
2.3 AC Characteristics .....	6
2.4 Lighting Specifications .....	8
<b>3. Optical Specifications</b> .....	9
3.1 LCD Driving Voltage .....	9
3.2 Optical Characteristics .....	9
Note 1: Definition of “Vth” .....	10
Note 2: Definition of Viewing Angle .....	10
Note 3: Definition of Response Time .....	11
<b>4. I/O Terminal</b> .....	12
4.1 Pin Assignment .....	12
4.2 Example of Power Supply .....	12
4.3 Block Diagram .....	13
<b>5. Reliability Test</b> .....	14
5.1 Test Item .....	14
5.2 Judgment Standard .....	15
<b>6. Appearance Standards</b> .....	16
6.1 Inspection Conditions .....	16
6.2 Definition of Applicable Zones .....	16
6.3 Standards .....	17
<b>7. Handling and Precautions</b> .....	19
<b>8. Warranty</b> .....	20
<b>9. Dimensional Outlines</b> .....	20



Messrs.					
Product Specification	Model	NMTC-S16208XFYHSGY-24A	Rev. No.	Issued Date.	Page.
			<i>A</i>	<i>Sep. 01, 17</i>	<i>4 / 21</i>

**The Microtips Customized LCD module, model: NMTC-S16208XFYHSGY-24A is compliant with RoHS**

## **1. General Specifications**

Operating Temperature.	:	Min. -20°C ~ Max. 70°C
Storage Temperature.	:	Min. -30°C ~ Max. 80°C
Display Format	:	16 characters x 2 lines
Display Fonts	:	5 x 7 dots + cursor (1 character)
Viewing Area	:	52.0 (W) x 19.4 (H) mm
Outline Dimensions	:	59.0 x 29.3 (H) x 5.5 max. (D) mm
Weight	:	N/A
LCD Type	:	STN / Yellow Green / Transflective
Viewing Direction	:	6:00
Backlight	:	Edge type LED (Yellow Green)
LCD LSI	:	ST 7066
Drawings	:	As attached drawings



***Microtips Technology Inc.***

Messrs.					
Product Specification	Model	NMTC-S16208XFYHSGY-24A	Rev. No.	Issued Date.	Page.
			A	Sep. 01, 17	5 / 21

## 2. Electrical Specifications

### 2.1 Absolute Maximum Ratings

$V_{SS} = 0V$

Parameter	Symbol	Min.	Max.	Units
Supply Voltage (Logic)	$V_{DD} - V_{SS}$	- 0.3	7.0	V
Supply Voltage (LCD Drive)	$V_{LCD}$	$V_{DD} - 15.0$	$V_{DD} + 0.3$	V
Input Voltage	$V_I$	- 0.3	$V_{DD} + 0.3$	V

### 2.2 DC Characteristics

$T_a = 25^\circ C, V_{SS} = 0V$

Parameter	Symbol	Conditions	Min.	Typ.	Max.	Units
Supply Voltage (Logic)	$V_{DD} - V_{SS}$	--	4.5	--	5.5	V
Supply Voltage (LCD Drive)	$V_{DD} - V_O$	Shown in 3.1				V
High Level (Input Voltage)	$V_{IH}$	$V_{DD} = 5.0V$	2.2	--	$V_{DD}$	V
Low Level (Input Voltage)	$V_{IL}$	$V_{DD} = 5.0V$	-0.3	--	0.6	V
High Level (Output Voltage)	$V_{OH}$	$I_{OH} = -0.205mA$	2.4	--	$V_{DD}$	V
Low Level (Output Voltage)	$V_{OL}$	$I_{OL} = 1.2mA$	0	--	0.4	V
Supply Current	$I_{DD}$	$V_{DD} - V_{SS} = 5.0V$	--	1.5	5.0	mA

$T_a = 25^\circ C, V_{SS} = 0V$

Parameter	Symbol	Conditions	Min.	Typ.	Max.	Units
Supply Voltage (Logic)	$V_{DD} - V_{SS}$	--	2.7	--	4.5	V
Supply Voltage (LCD Drive)	$V_{DD} - V_O$	Shown in 3.1				V
High Level (Input Voltage)	$V_{IH}$	$V_{DD} = 3.0V$	$0.7 V_{DD}$	--	$V_{DD}$	V
Low Level (Input Voltage)	$V_{IL}$	$V_{DD} = 3.0V$	-0.3	--	0.55	V
High Level (Output Voltage)	$V_{OH}$	$I_{OH} = -0.1mA$	$0.75 V_{DD}$	--	$V_{DD}$	V
Low Level (Output Voltage)	$V_{OL}$	$I_{OL} = 0.1mA$	0	--	$0.2 V_{DD}$	V
Supply Current	$I_{DD}$	$V_{DD} - V_{SS} = 5.0V$	--	1.5	5.0	mA



**Microtips Technology Inc.**

Messrs.					
Product Specification	Model	NMTC-S16208XFYHSGY-24A	Rev. No.	Issued Date.	Page.
			A	Sep. 01, 17	6 / 21

### 2.3 AC Characteristics

$V_{DD} = 4.5V \sim 5.5V$

Parameter	Symbol	Conditions	Min.	Max.	Units
Enable Cycle Time	$t_{CYC}$	Fig.1, 2	500	--	ns
Enable Pulse Width	$PW_{EH}$	Fig.1, 2	230	--	ns
Enable Rise / Fall Time	$t_{Er}, t_{Ef}$	Fig.1, 2	--	20	ns
Address Setup Time	$t_{AS}$	Fig.1, 2	40	--	ns
Address Hold Time	$t_{AH}$	Fig.1, 2	10	--	ns
Write Data Setup Time	$t_{DSW}$	Fig.1	80	--	ns
Write Data Hold Time	$t_{DHW}$	Fig.1	10	--	ns
Read Data Delay Time	$t_{DDR}$	Fig.2	--	120	ns
Read Data Hold Time	$t_{DHR}$	Fig.2	5	--	ns

$V_{DD} = 2.7V \sim 4.5V$

Parameter	Symbol	Conditions	Min.	Max.	Units
Enable Cycle Time	$t_{CYC}$	Fig.1, 2	1000	--	ns
Enable Pulse Width	$PW_{EH}$	Fig.1, 2	450	--	ns
Enable Rise / Fall Time	$t_{Er}, t_{Ef}$	Fig.1, 2	--	25	ns
Address Setup Time	$t_{AS}$	Fig.1, 2	60	--	ns
Address Hold Time	$t_{AH}$	Fig.1, 2	20	--	ns
Write Data Setup Time	$t_{DSW}$	Fig.1	195	--	ns
Write Data Hold Time	$t_{DHW}$	Fig.1	10	--	ns
Read Data Delay Time	$t_{DDR}$	Fig.2	--	360	ns
Read Data Hold Time	$t_{DHR}$	Fig.2	5	--	ns



*Microtips Technology Inc.*

Product Specification	Model	NMTC-S16208XFYHSGY-24A	Rev. No.	Issued Date.	Page.
			A	Sep. 01, 17	7 / 21

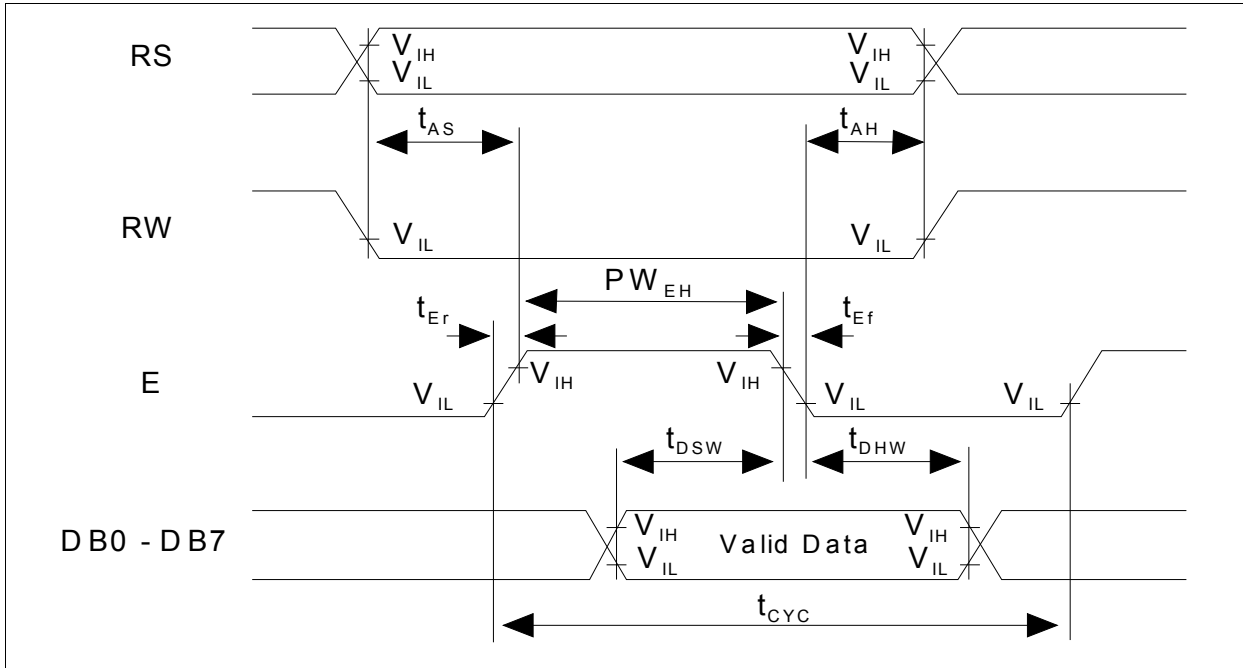

**Fig.1 Write Operation Timing**

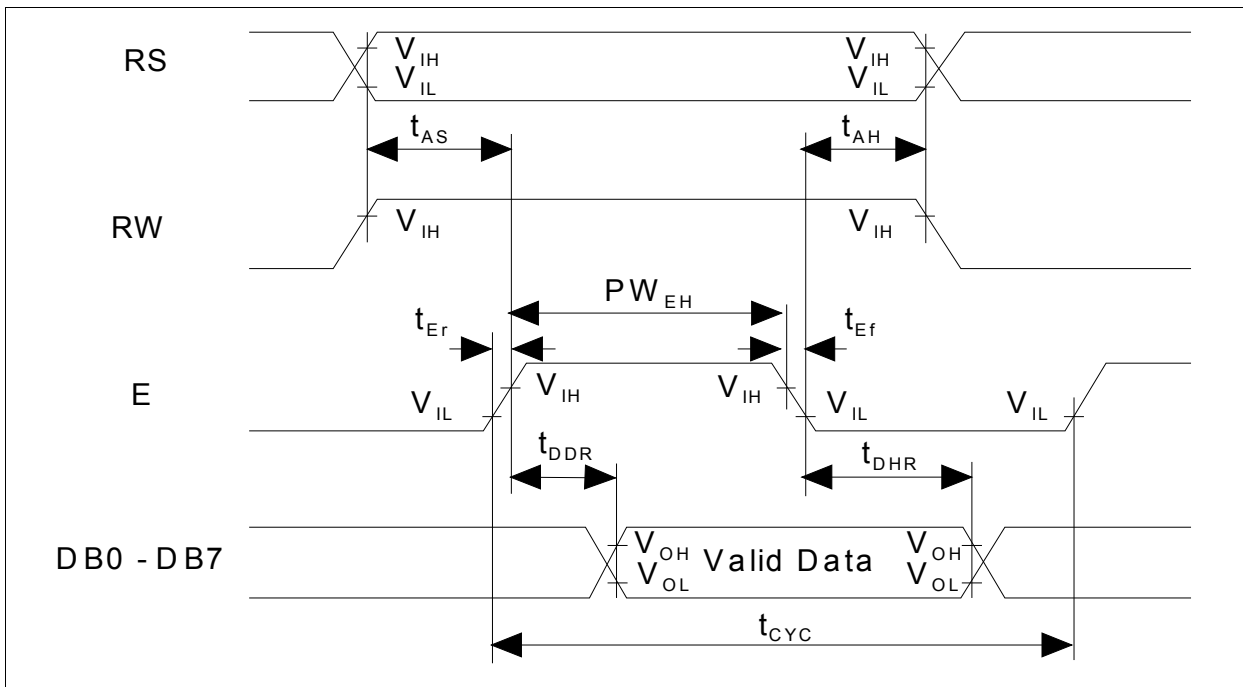

**Fig.2 Read Operation Timing**



Messrs.					
Product Specification	Model	NMTC-S16208XFYHSGY-24A	Rev. No.	Issued Date.	Page.
			A	Sep. 01, 17	8 / 21

## 2.4 Lighting Specifications

### 2.4.1 Absolute Maximum Ratings

Ta = 25°C

Parameter	Symbol	Conditions	Min.	Typ.	Max.	Units
LED Power Dissipation	P <sub>D</sub>	--	--	--	288	mW
Reverse Voltage	V <sub>R</sub>	--	--	--	10	V
Forward Current	I <sub>F</sub>	--	--	--	60	mA

### 2.4.2 Operating Characteristics

Ta = 25°C

Parameter	Symbol	Conditions	Min.	Typ.	Max.	Units
Forward Voltage	V <sub>F</sub>	I <sub>F</sub> = 20 x 2 = 40mA	--	4.2	4.8	V
Luminous Intensity	I <sub>V</sub>		21	30	--	mcd
Peak emission Wavelength	λ <sub>p</sub>		--	565	--	nm
Dominant Wavelength	λ <sub>d</sub>		--	572	--	nm
Chromaticity Coordinates	X		0.43	0.46	0.49	--
	Y		0.56	0.53	0.50	

\*Measured from the surface of backlight.

\*Luminance Tolerance = (Max – Min / Max) x 100%



*Microtips Technology Inc.*



Messrs.					
Product Specification	Model	NMTC-S16208XFYHSGY-24A	Rev. No.	Issued Date.	Page.
			A	Sep. 01, 17	9 / 21

### 3. Optical Specifications

#### 3.1 LCD Driving Voltage

Parameter	Symbol	Conditions	Min.	Typ.	Max.	Units
Recommended LCD Driving Voltage Note 1	-20 °C	VOP	4.48	4.68	4.88	V
	25 °C		4.32	4.6	4.82	
	70 °C		4.25	4.45	4.65	

Note 1: Voltage (Applied actual waveform to LCD Module) for the best contrast. The range of minimum and maximum shows tolerance of the operating voltage. The specified contrast ratio and response time are not guaranteed over the entire range.

#### 3.2 Optical Characteristics

Ta = 25 °C, 1/16 Duty, 1/5 Bias, V<sub>DD</sub> = 5.0V (Note 4), θ = 0°, φ = 270°

Parameter	Symbol	Conditions	Min.	Typ.	Max.	Units
Contrast Ratio Note 4	CR	Ta = 25 °C	5	15	--	--
Viewing Angle Note 2	θ = 90	Ta = 25 °C	--	15	--	deg.
	θ = 270		--	40	--	deg.
	θ = 0		--	35	--	deg.
	θ = 180		--	35	--	deg.
Response Time Note 3	T <sub>r</sub>	Ta = 25 °C	--	120	--	ms
	T <sub>f</sub>		--	100	--	ms

Note 1: Contrast ratio is defined as follows.  $CR = L_{OFF} / L_{ON}$

L<sub>ON</sub>: Luminance of the ON segments, L<sub>OFF</sub>: Luminance of the OFF segments

Note 2: The time that the luminance level reaches 90% of the saturation level from 0% when ON signal is applied.

Note 3: The time that the luminance level reaches 10% of the saturation level from 100% when OFF signal is applied.

Note 4: Definition of Driving Voltage V<sub>D</sub>. Assuming that the typical driving waveforms shown below are applied to the LCD Panel at 1/A Duty – 1/B Bias ( A: Duty Number, B: Bias Number ). Driving voltage V<sub>D</sub> is defined as follows:  $V_D = (V_{th1} + V_{th2}) / 2$

V<sub>th1</sub>: The voltage V<sub>O – P</sub> that should provide 50% of the saturation level in the luminance at the segment which the ON signal is applied to.

V<sub>th2</sub>: The voltage V<sub>O – P</sub> that should provide 50% of the saturation level in the luminance at the segment which the OFF signal is applied to.

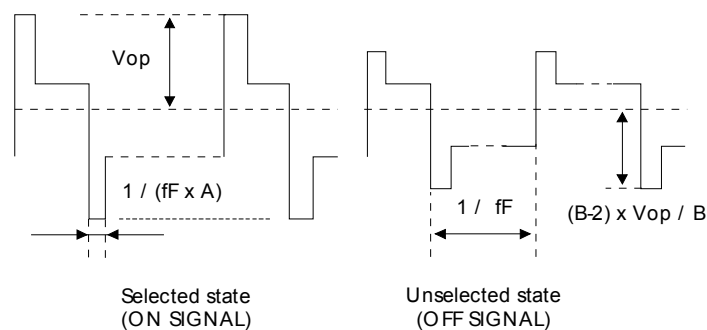

Microtips Technology Inc.

Messrs.					
Product Specification	Model	NMTC-S16208XFYHSGY-24A	Rev. No.	Issued Date.	Page.
			A	Sep. 01, 17	10 / 21

Note 1: Definition of "Vth"

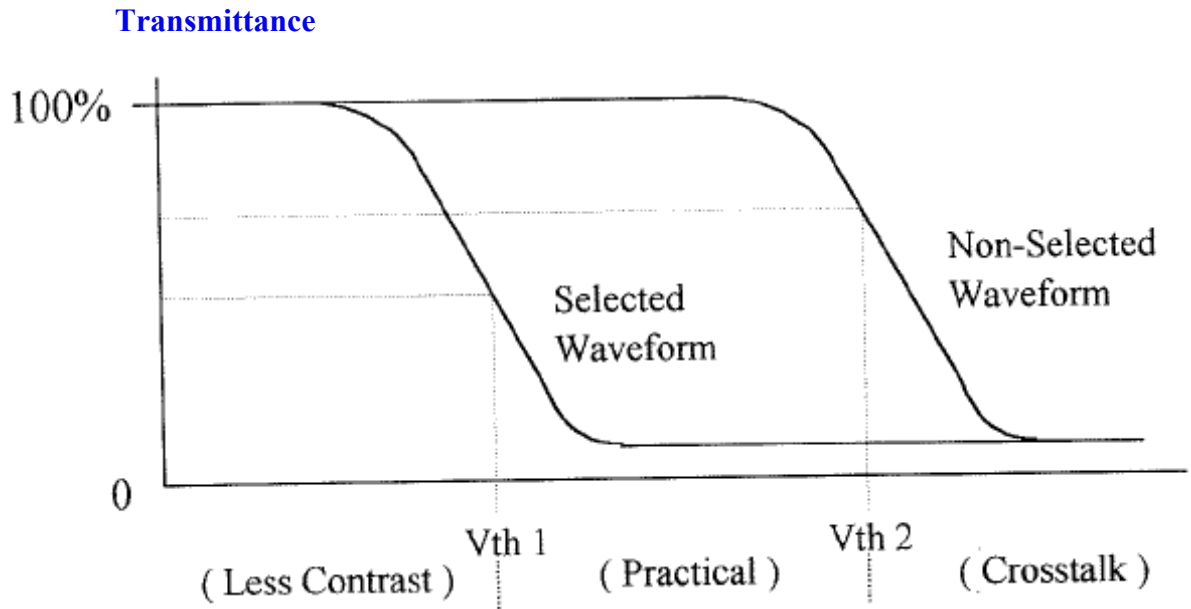

Note 2: Definition of Viewing Angle

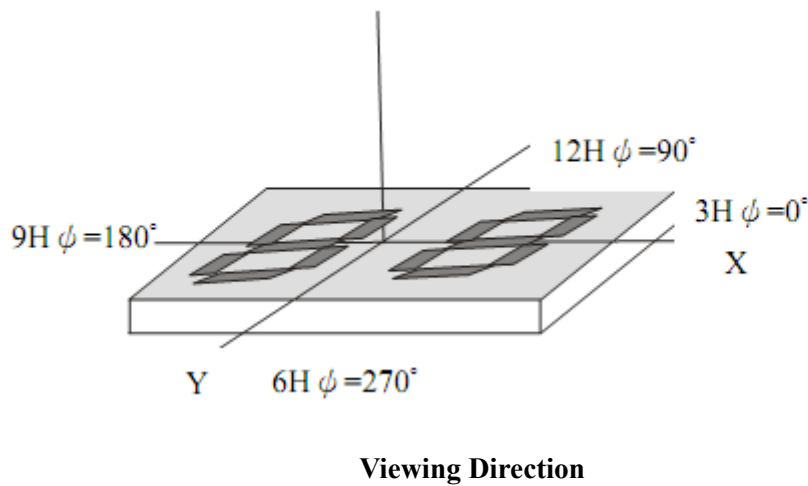

**Microtips Technology Inc.**

Messrs.					
Product Specification	Model	NMTC-S16208XFYHSGY-24A	Rev. No.	Issued Date.	Page.
			A	Sep. 01, 17	11 / 21

Note 3: Definition of Response Time

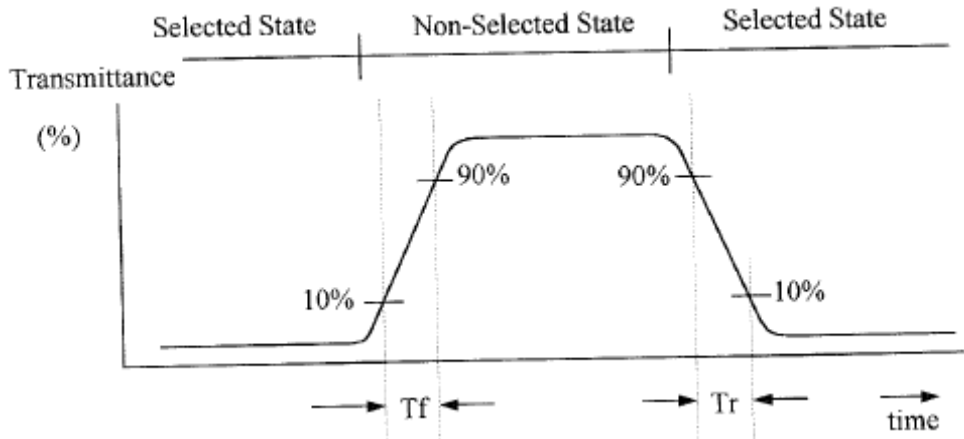

**Measurement Condition: Viewing Angle:  $\phi_2 = 0^\circ$ ,  $\phi_1 = 0^\circ$**

Note 4: Definition of Contrast Ratio

$$(a) \text{ Contrast Ratio} = \frac{\text{Transmittance under Non - Selected Waveform}}{\text{Transmittance under Selected Waveform}}$$

(b) Measurement Condition: Viewing Angle:  $\theta_2 = 0^\circ$ ,  $\theta_1 = 0^\circ$



**Microtips Technology Inc.**

Messrs.					
Product Specification	Model	NMTC-S16208XFYHSGY-24A	Rev. No.	Issued Date.	Page.
			A	Sep. 01, 17	12 / 21

## 4. I/O Terminal

### 4.1 Pin Assignment

No.	Symbol	Level	Function
1.	VLED (-)	--	LED backlight enable pin
2.	VSS	--	Power Supply (0V, GND)
3.	VDD	--	Power Supply for Logic
4.	VEE (Vo)	--	Power Supply for LCD Drive
5.	RS	H / L	Register Select Signal
6.	R/W	H / L	Read / Write Select Signal H: Read L: Write
7.	E	H / L	Enable Signal (No pull – up Resister)
8.	DB0	H / L	Data Bus Line / Non – connection at 4 – bit operation
9.	DB1	H / L	Data Bus Line / Non – connection at 4 – bit operation
10.	DB2	H / L	Data Bus Line / Non – connection at 4 – bit operation
11.	DB3	H / L	Data Bus Line / Non – connection at 4 – bit operation
12.	DB4	H / L	Data Bus Lin
13.	DB5	H / L	Data Bus Line
14.	DB6	H / L	Data Bus Line
15.	DB7	H / L	Data Bus Line

### 4.2 Example of Power Supply

It is recommended to apply a potentiometer for the contrast adjust due to the tolerance of the driving voltage and its temperature dependence.

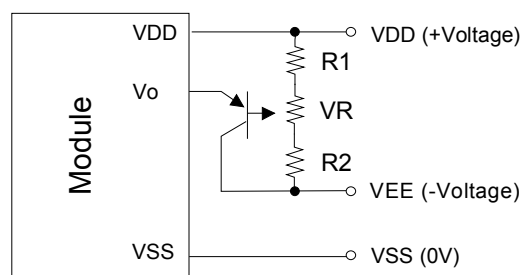

$$R1+R2+VR=10 \sim 20K\Omega$$

$$Tr=2SA1202 \text{ or equivalent}$$



Messrs.					
Product Specification	Model	NMTC-S16208XFYHSGY-24A	Rev. No.	Issued Date.	Page.
			A	Sep. 01, 17	13 / 21

4.3 Block Diagram

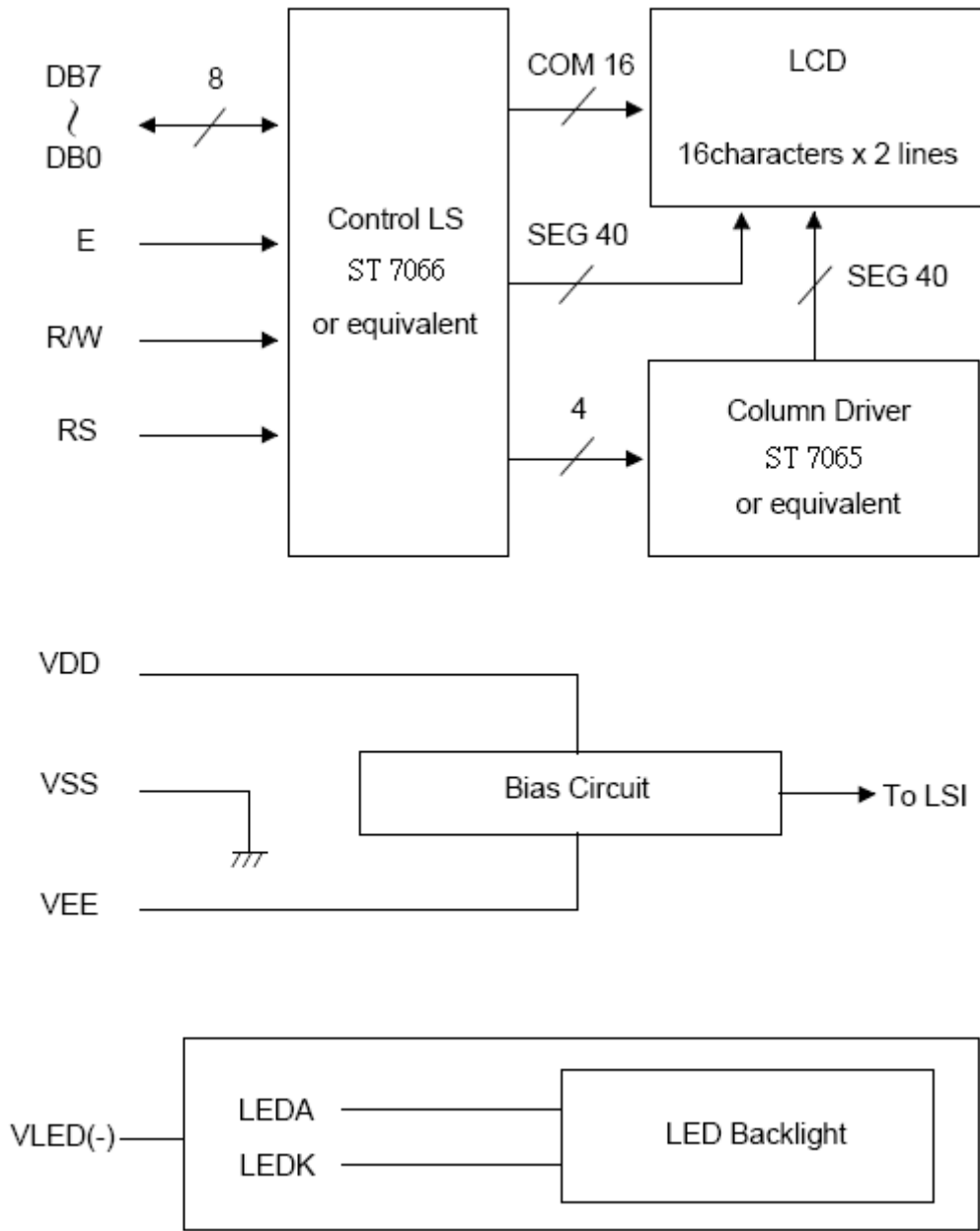

Messrs.					
Product Specification	Model	NMTC-S16208XFYHSGY-24A	Rev. No.	Issued Date.	Page.
			A	Sep. 01, 17	14 / 21

## 5. Reliability Test

### 5.1 Test Item

No change on display and in operation under the following test condition.

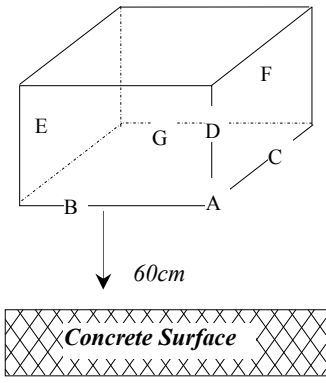
No.	Test Item	Description	Condition	Note
1.	High Temperature (Operation)	Durability test under long time high temperature with electrical stress (voltage, current)	70°C ± 2°C 240hrs	--
2.	High Temperature (Storage)	Durability test under long time high temperature storage	80°C ± 2°C 240hrs	4
3.	Low Temperature (Operation)	Durability test under long time low temperature with electrical stress (voltage, current)	-20°C ± 2°C 240hrs	3
4.	Low Temperature (Storage)	Durability test under long time low temperature storage	-30°C ± 2°C 240hrs	3, 4
5.	Damp Proof Test	Durability test under long time high temperature and high humidity	40°C ± 2°C, 90% RH 240hrs	3, 4
6.	Vibration Test	Total fixed amplitude: 1.5mm Vibration frequency: 10~55Hz One cycle 60 seconds to 3 directions of X, Y, Z for each 15 minutes	--	5
7.	Drop Test	To be measured after dropping from 60cm high on the concrete surface in packing state. 	<p><i>Dropping method corner dropping</i> A corner: once</p> <p><i>Edge dropping</i> B, C, D edge: once</p> <p><i>Face dropping</i> E, F, G face: once</p>	--

Note 1: Unless otherwise specified, tests will be conducted under the following condition,

Temperature : 25°C ± 2°C

Humidity : 65% ± 5%

Note 2: Unless otherwise specified, tests will be not conducted under functioning state.

Note 3: No dew condensation to be observed.

Note 4: The function test shall be conducted after 4 hours storage at the normal temperature and humidity after removed from the test chamber.

Note 5: Vibration test will be conducted to the product itself without putting it in a container.



**Microtips Technology Inc.**

Messrs.					
Product Specification	Model	NMTC-S16208XFYHSGY-24A	Rev. No.	Issued Date.	Page.
			A	Sep. 01, 17	15 / 21

## 5.2 Judgment Standard

Failure Mode	Test Item							Judgment Standard
	1.	2.	3.	4.	5.	6.	7.	
Orientation	*	*	*	*	*			No remarkable degradation of appearance under bias / non – bias condition
Current Value (IAC)	*	*	*	*	*			No remarkable increase
Contrast	*		*	*	*			No remarkable poor contrast
Domain	*	*	*	*	*			Less than 20% of all dots have reverse tilt of more than on third of one dot area.
Bubble (Inside Cell)	*	*	*	*	*	*		As per “Appearance Standard” (Note. In – cluding one which disappear after 25°C 2H)
Polarizer	*				*	*		As per “Appearance Standard” no remarkable appearance change
Glass Damage							*	As per “Appearance Standard”

Note 1.\* is strong linkage between Failure Mode and Test Item

2. Number of Test Item should be referred to former page.

3. Judgment and Standard value should be fixed by other inspection standard and criteria samples.



*Microtips Technology Inc.*

Messrs.					
Product Specification	Model	NMTC-S16208XFYHSGY-24A	Rev. No.	Issued Date.	Page.
			A	Sep. 01, 17	16 / 21

## 6. Appearance Standards

### 6.1 Inspection Conditions

The LCD shall be inspected under 40W white fluorescent light. The distance between the eyes and the sample shall be more than 30cm. All directions for inspecting the sample should be within 45° against perpendicular line.

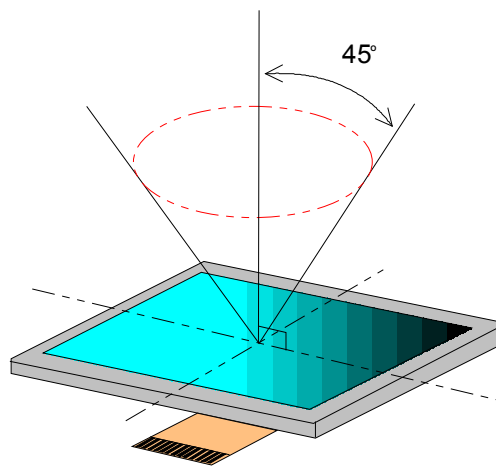

### 6.2 Definition of Applicable Zones

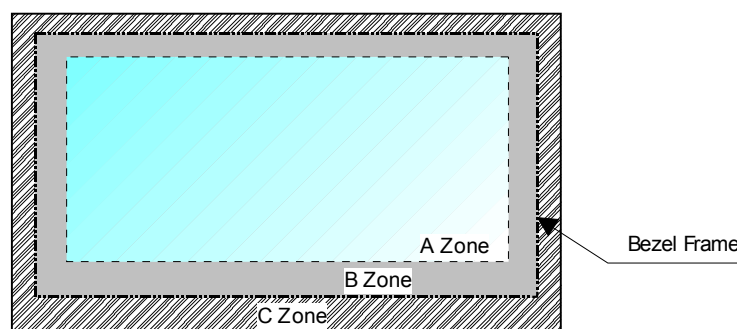

A Zone: Active display area

B Zone: Area from outside of "A Zone" to validity viewing area

C Zone: Rest parts

A Zone + B Zone = Validity viewing area



**Microtips Technology Inc.**



Messrs.					
Product Specification	Model	NMTC-S16208XFYHSGY-24A	Rev. No.	Issued Date.	Page.
			A	Sep. 01, 17	17 / 21

### 6.3 Standards

No.	Parameter	Criteria																																																							
1.	Black and White Spots, Foreign Substances	<p>(1) Round Shape</p> <table border="1"> <thead> <tr> <th rowspan="2">Dimension (mm) \ Zone</th> <th colspan="3">Acceptable Number</th> </tr> <tr> <th>A</th> <th>B</th> <th>C</th> </tr> </thead> <tbody> <tr> <td>D ≤ 0.1</td> <td>*</td> <td>*</td> <td>*</td> </tr> <tr> <td>0.1 &lt; D ≤ 0.2</td> <td>3</td> <td>5</td> <td>*</td> </tr> <tr> <td>0.2 &lt; D ≤ 0.25</td> <td>2</td> <td>3</td> <td>*</td> </tr> <tr> <td>0.25 &lt; D ≤ 0.3</td> <td>0</td> <td>1</td> <td>*</td> </tr> <tr> <td>0.3 &lt; D</td> <td>0</td> <td>0</td> <td>*</td> </tr> </tbody> </table> <p>D = (Long + Short) / 2    *: Disregard</p> <p>(2) Line Shape</p> <table border="1"> <thead> <tr> <th rowspan="2">Zone \ X (mm)</th> <th rowspan="2">Zone \ Y (mm)</th> <th colspan="3">Acceptable Number</th> </tr> <tr> <th>A</th> <th>B</th> <th>C</th> </tr> </thead> <tbody> <tr> <td>--</td> <td>0.03 ≥ W</td> <td>*</td> <td>*</td> <td>*</td> </tr> <tr> <td>2.0 ≥ L</td> <td>0.05 ≥ W</td> <td>3</td> <td>3</td> <td>*</td> </tr> <tr> <td>1.0 ≥ L</td> <td>0.1 ≥ W</td> <td>3</td> <td>3</td> <td>*</td> </tr> <tr> <td>--</td> <td>0.1 &lt; W</td> <td colspan="3">In the same way (1)</td> </tr> </tbody> </table> <p>X: Length    Y: Width    *: Disregard</p> <p>Total defects shall not exceed 5.</p>	Dimension (mm) \ Zone	Acceptable Number			A	B	C	D ≤ 0.1	*	*	*	0.1 < D ≤ 0.2	3	5	*	0.2 < D ≤ 0.25	2	3	*	0.25 < D ≤ 0.3	0	1	*	0.3 < D	0	0	*	Zone \ X (mm)	Zone \ Y (mm)	Acceptable Number			A	B	C	--	0.03 ≥ W	*	*	*	2.0 ≥ L	0.05 ≥ W	3	3	*	1.0 ≥ L	0.1 ≥ W	3	3	*	--	0.1 < W	In the same way (1)		
Dimension (mm) \ Zone	Acceptable Number																																																								
	A	B	C																																																						
D ≤ 0.1	*	*	*																																																						
0.1 < D ≤ 0.2	3	5	*																																																						
0.2 < D ≤ 0.25	2	3	*																																																						
0.25 < D ≤ 0.3	0	1	*																																																						
0.3 < D	0	0	*																																																						
Zone \ X (mm)	Zone \ Y (mm)	Acceptable Number																																																							
		A	B	C																																																					
--	0.03 ≥ W	*	*	*																																																					
2.0 ≥ L	0.05 ≥ W	3	3	*																																																					
1.0 ≥ L	0.1 ≥ W	3	3	*																																																					
--	0.1 < W	In the same way (1)																																																							
2.	Air Bubbles (between glass & polarizer)	<table border="1"> <thead> <tr> <th rowspan="2">Dimension (mm) \ Zone</th> <th colspan="3">Acceptable Number</th> </tr> <tr> <th>A</th> <th>B</th> <th>C</th> </tr> </thead> <tbody> <tr> <td>D ≤ 0.3</td> <td>*</td> <td>*</td> <td>*</td> </tr> <tr> <td>0.3 &lt; D ≤ 0.4</td> <td>3</td> <td>*</td> <td>*</td> </tr> <tr> <td>0.4 &lt; D ≤ 0.6</td> <td>2</td> <td>3</td> <td>*</td> </tr> <tr> <td>0.6 &lt; D</td> <td>0</td> <td>0</td> <td>*</td> </tr> </tbody> </table> <p>*: Disregard</p> <p>Total defects shall not exceed 3.</p>	Dimension (mm) \ Zone	Acceptable Number			A	B	C	D ≤ 0.3	*	*	*	0.3 < D ≤ 0.4	3	*	*	0.4 < D ≤ 0.6	2	3	*	0.6 < D	0	0	*																																
Dimension (mm) \ Zone	Acceptable Number																																																								
	A	B	C																																																						
D ≤ 0.3	*	*	*																																																						
0.3 < D ≤ 0.4	3	*	*																																																						
0.4 < D ≤ 0.6	2	3	*																																																						
0.6 < D	0	0	*																																																						

To be continued.....



**Microtips Technology Inc.**

Messrs.

Product Specification	Model	NMTC-S16208XFYHSGY-24A	Rev. No.	Issued Date.	Page.
			A	Sep. 01, 17	18 / 21

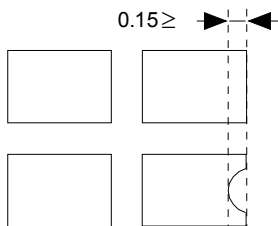
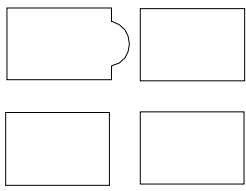
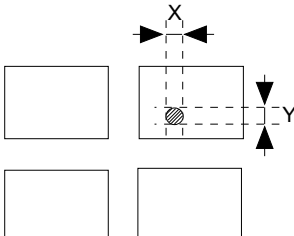
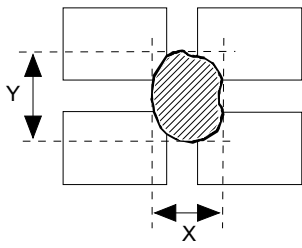
No.	Parameter	Criteria
3.	The Shape of Dot	<p>(1) Dot Shape (with Dent)</p>  <p>As per the sketch of left hand.</p> <p>(2) Dot Shape (with Projection)</p>  <p>Should not be connected to next dot.</p> <p>(3) Pin Hole</p>  <p><math>(X + Y) / 2 \leq 0.2\text{mm}</math> (Less than 0.1mm is no counted.)</p> <p>(4) Deformation</p>  <p><math>(X + Y) / 2 \leq 0.2\text{mm}</math></p> <p>Total acceptable number: 1/dot, 5/cell (Defect number of (4): 1pc.)</p>
4.	Polarizer Scratches	Not to be conspicuous defects.
5.	Polarizer Dirt's	If the stains are removed easily from LCDP surface, the module is not defective.
6.	Complex Foreign Substance Defects	Black spots, line shaped foreign substance or air bubbles between glass & polarizer should be 5pcs maximum in total.
7.	Distance between different Foreign Substance defects	$D \leq 0.2$ : 20mm or more $0.2 < D$ : 40mm or more



Microtips Technology Inc.

Messrs.					
Product Specification	Model	NMTC-S16208XFYHSGY-24A	Rev. No.	Issued Date.	Page.
			<i>A</i>	<i>Sep. 01, 17</i>	<i>19 / 21</i>

## 7. Handling and Precautions

The Following precautions will guide you in handling our product correctly.

- 1 Liquid crystal display devices
  - 1.1 The liquid crystal display device panel used in the liquid crystal display module is made of plate glass. Avoid any strong mechanical shock. Should the glass break handle it with care.
  - 1.2 The polarizer adhering to the surface of the LCD is made of a soft material. Guard against scratching it.
  
- 2 Care of the liquid crystal display module against static electricity discharge.
  - 2.1 When working with the module, be sure to ground your body and any electrical equipment you may be using. We strongly recommend the use of anti static mats (made of rubber ), to protect work tables against the hazards of electrical shock.
  - 2.2 Avoid the use of work clothing made of synthetic fibers. We recommend cotton clothing or other conductivity-treated fibers.
  - 2.3 Slowly and carefully remove the protective film from the LCD module, since this operation can generate static electricity.
  
- 3 When the LCD module alone must be stored for long periods of time:
  - 3.1 Protect the modules from high temperature and humidity.
  - 3.2 Keep the modules out of direct sunlight or direct exposure to ultra-violet rays.
  - 3.3 Protect the modules from excessive external forces.
  
- 4 Use the module with a power supply that is equipped with an over current protector circuit, since the module is not provided with this protective feature.
  
- 5 Do not ingest the LCD fluid itself should it leak out of a damaged LCD module. Should hands or clothing come in contact with LCD fluid, wash immediately with soap.
  
- 6 Conductivity is not guaranteed for models that use metal holders where solder connections between the metal holder and the PCB are not used. Please contact us to discuss appropriate ways to assure conductivity.



Messrs.					
Product Specification	Model	NMTC-S16208XFYHSGY-24A	Rev. No.	Issued Date.	Page.
			<i>A</i>	<i>Sep. 01, 17</i>	20 / 21

## 8. Warranty

This product has been manufactured to your company's specifications as a part for use in your company's general electronic products. It is guaranteed to perform according to delivery specifications. For any other use apart from general electronic equipment, we cannot take responsibility if the product is used in medical devices, nuclear power control equipment, aerospace equipment, fire and security systems, or any other applications in which there is a direct risk to human life and where extremely high levels of reliability are required. If the product is to be used in any of the above applications, we will need to enter into a separate product liability agreement.

- 1 13-month guarantee starts from the date code.
- 2 We cannot accept responsibility for any defect, which may arise from additional manufacturing of the product (including disassembly and reassembly), after product delivery.
- 3 We cannot accept responsibility for any defect, which may arise after the application of strong external force to the product.
- 4 We cannot accept responsibility for any defect, which may arise due to the application of static electricity after the product has passed your company's acceptance inspection procedures.
- 5 We cannot accept responsibility for industrial property, which may arise through the use of your product, with exception to those issues relating directly to the structure or method of manufacturing of our product. Microtips-origin longer than one year from Microtips production.

## 9. Dimensional Outlines

- See the next page.....



*Microtips Technology Inc.*

REV.	DESCRIPTION	DRAWN	CHECK	APP'D	DATE
△	Production Release	Addison	Chris L.		04/13/00

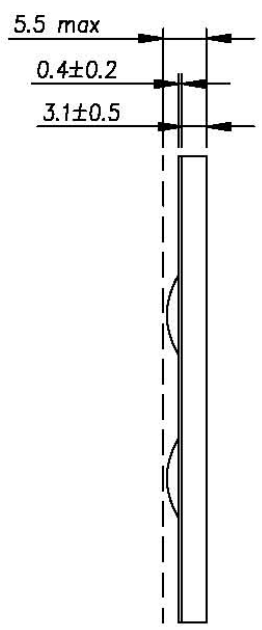
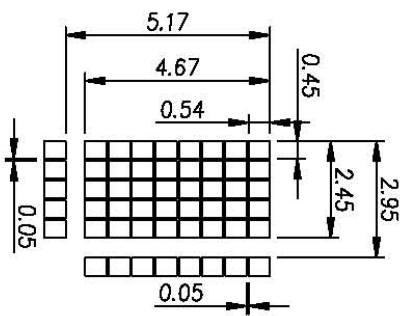
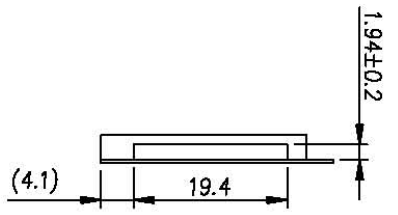
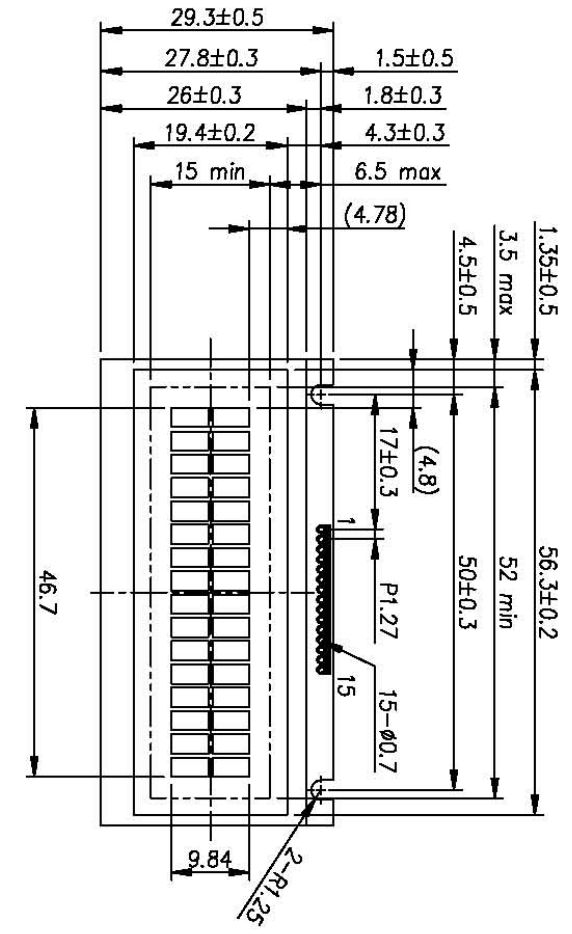

PIN ASSIGNMENT							
1	VLED(-)	5	RS	9	DB1	13	DB5
2	VSS	6	R/W	10	DB2	14	DB6
3	VDD	7	E	11	DB3	15	DB7
4	VO	8	DB0	12	DB4		

NO.		M-16208X		DATE: 04/13/00		MATERIAL		FINISH	
PART NAME		DRAWN: Addison		CHECK: Chris L. Sunny T.		SCALE: 1/1		FOR MODULE: MTC-16208X	
Microtips Technology		UNIT: MM		UNLESS OTHERWISE SPECIFIED TOLERANCE ON FRACTIONS DEIGMALS ANGLES 0.10 0.5°		DWG NO.: C16208X0		FILE: D:\Design\LCM\MTC\MTC-16208X\2D	
Addison		Chris L. Sunny T.		SHEET 1 / 1		Rev. A			