



SY84782U

Low Power 2.5V 1.25Gbps FP/DFB Laser Diode Driver

General Description

The SY84782U is a single 2.5V supply, ultra-low power, small form factor laser diode driver for telecom/datacom applications. Intended to drive FP/DFB lasers at data rates up to 1.25Gbps, it is especially useful for Compact SFP, SFP and SFF modules where power requirements are quite stringent. The driver can deliver modulation current up to 90mA and offers a high compliance voltage, all of which make the SY84782U suitable for high current operations in both AC and DC coupled applications.

The SY84782U is intended to be used with Micrel's MIC3003 Optical Transceiver Management IC, which allows for both modulation and bias current control and monitoring. Furthermore, the MIC3003 offers power control and temperature compensation.

This device operates across the industrial temperature range (-40°C to +85°C) and is available in a small 3mm x 3mm QFN package.

All datasheets and support documentation can be found on Micrel's web site at: www.micrel.com.

Features

- 2.5V power supply option
- Ultra low power consumption (63mW typ)
- Multirate up to 1.25Gbps
- Fast rise and fall time
- Modulation current up to 90mA
- Laser may be DC or AC coupled
- Guaranteed operation over -40°C to +85°C temperature range
- Small form factor 16-pin (3mm x 3mm) QFN package
- MIC3003G Compatible

Applications

- Multirate LAN, MAN applications: Fibre Channel, GbE, SONET OC3/12/24 and SDH STM1/4/8
- CSFP/SFF/SFP Optical Modules

Typical Application

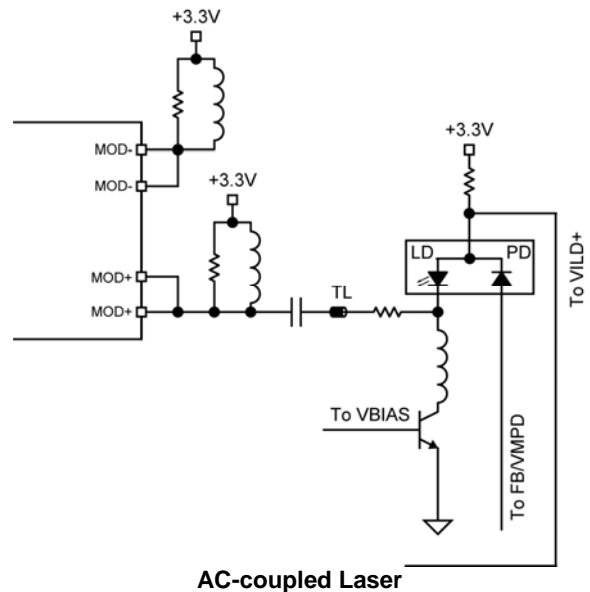
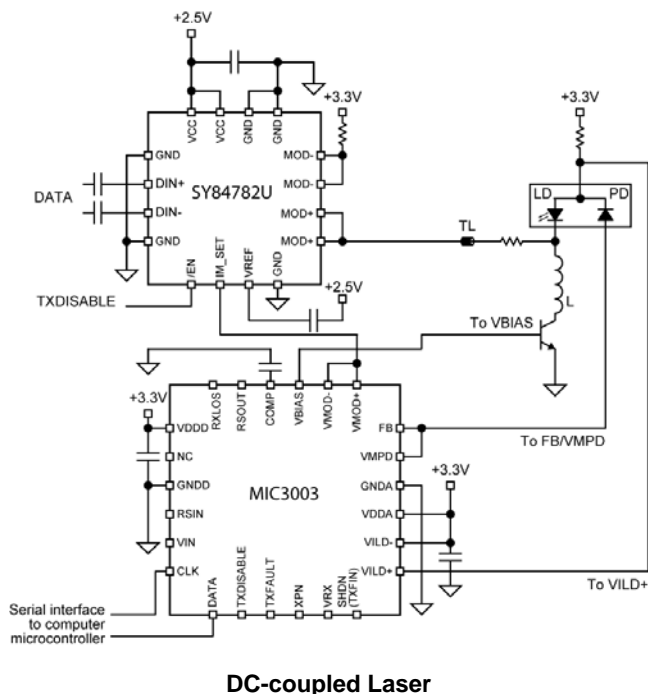

Functional Block Diagram

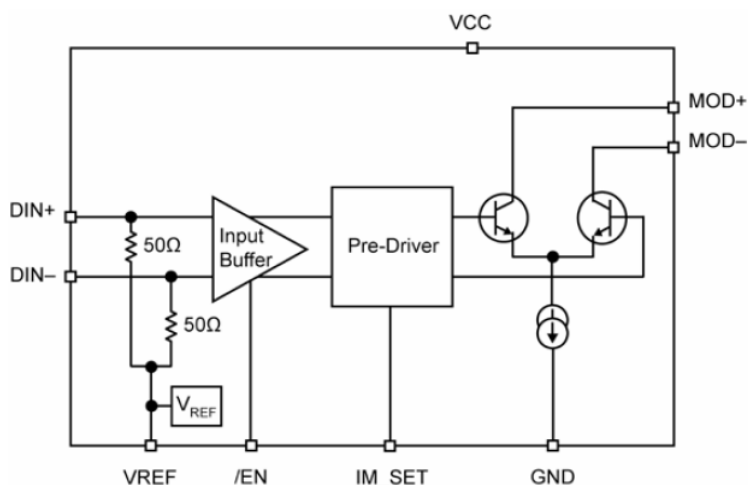

Ordering Information

Part Number	Package Type	Operating Range	Package Marking	Lead Finish
SY84782UMG	QFN-16	Industrial	782U Pb-Free bar-line indicator	Pb-Free
SY84782UMG TR ⁽¹⁾	QFN-16	Industrial	782U Pb-Free bar-line indicator	Pb-Free

Note:

1. Tape and Reel

Pin Configuration

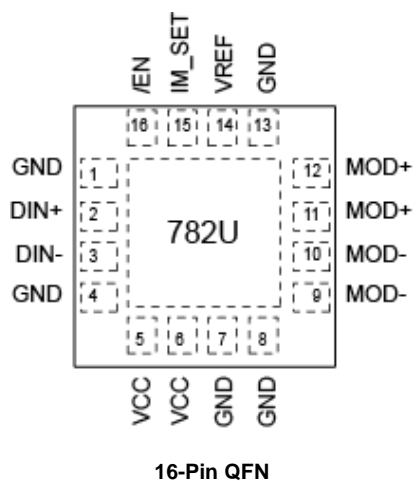

Pin Description

Pin Number	Pin Name	Pin Function
1, 4, 7, 8, 13	GND, Exposed Pad	Device Ground. Ground and exposed pad must be connected to the plane of the most negative potential.
2	DIN+	Non-Inverting Input Data. Internally terminated with 50Ohm to a reference voltage
3	DIN-	Inverting Input Data. Internally terminated with 50Ohm to a reference voltage
5, 6	VCC	Supply Voltage. Bypass with a 0.1uF 0.01uF low ESR capacitor as close to VCC pin as possible.
9, 10	MOD-	Inverted Modulation Current Output. Provides modulation current when input data is negative
11, 12	MOD+	Non-Inverted Modulation Current Output. Provides modulation current when input data is positive.
14	VREF	Reference Voltage. Install a 0.1uF capacitor between VREF and VCC
15	IM_SET	Modulation current setting and control. The voltage applied to this pin will set the modulation current. To be connected to the MIC3003 pin 24 (VMOD+). Input impedance 25KOhm.
16	/EN	Enable Pin. A high level signal applied to this pin will pull the MOD+ output HIGH and MOD- output LOW. Internally pulled down with a 75KOhm resistor.

Truth Table

DIN+	DIN-	/EN	MOD+ ⁽¹⁾	MOD-	Laser Output ⁽²⁾
L	H	L	H	L	L
H	L	L	L	H	H
X	X	H	H	L	L

Notes:

- $I_{MOD} = 0$ when MOD+ = H
- Assuming that Laser is tied to MOD+

Absolute Maximum Ratings⁽¹⁾

Supply Voltage (V_{CC})	-0.5V to +3.0V
Input Voltage (V_{IN})	-0.5V to V_{CC}
TTL Control Input Voltage (V_{IN})	0V to V_{CC}
Lead Temperature (soldering, 20 sec.)	+260°C
Storage Temperature (T_S)	-65°C to +150°C

Operating Ratings⁽²⁾

Supply Voltage (V_{CC})	2.375V to 2.625V
Ambient Temperature (T_A)	-40°C to +85°C
Package Thermal Resistance ⁽³⁾		
Still-Air (θ_{JA})	60°C/W
Junction-to-Board (Ψ_{JB})	33°C/W

DC Electrical Characteristics⁽⁴⁾

$V_{CC} = 2.5V \pm 5\%$, $T_A = -40^\circ C$ to $+85^\circ C$. Typical values are $V_{CC} = 2.5V$, $T_A = 25^\circ C$, $I_{MOD} = 60mA$

Symbol	Parameter	Condition	Min	Typ	Max	Units
I_{CC}	Power Supply Current	Modulation current excluded		24	30 ⁽⁵⁾	mA
V_{MOD_MIN}	Minimum voltage required at driver output for proper operation		0.6			V
$R_{iIN(DATA)}$	Input resistance (DIN+, DIN-)		45	50	55	Ω
$R_{iIN(IMOD_SET)}$	Input resistance (IM_SET)			25		k Ω
V_{ID}	Differential Input Voltage Swing		200		2400	mVpp
V_{IH_EN}	/EN Input High		2			V
V_{IL_EN}	/EN Input Low				0.8	V
V_{IM_SET}	Voltage Range on IM_SET Pin	I_{MOD} range 10mA – 90mA			1.2	V

AC Electrical Characteristics⁽⁴⁾

$V_{CC} = 2.5V \pm 5\%$, $T_A = -40^\circ C$ to $+85^\circ C$. Typical values are $V_{CC} = 2.5V$, $T_A = 25^\circ C$, $I_{MOD} = 60mA$

Symbol	Parameter	Condition	Min	Typ	Max	Units
	Data Rate	NRZ Data	0.155		1.25	Gbps
I_{MOD}	Modulation Current (15 Ω Load)	AC-Coupled	10		90	mA
		DC-Coupled	10		70 ⁽⁶⁾	mA
I_{MOD_OFF}	Modulation OFF current	Current at MOD+ when the device is disabled			750	μA
	Total Jitter	@ 1.25Gbps data rate			20	pspp
	Pulse-Width Distortion	I_{MOD} range 10mA – 90mA			20	ps
t_r, t_f	Output Rise/Fall Times (20% to 80%)	15 Ω Load		100	140	ps

Notes:

1. Exceeding the absolute maximum rating may damage the device.
2. The device is not guaranteed to function outside its operating rating.
3. Package Thermal Resistance assumes exposed pad is soldered (or equivalent) to the devices most negative potential on the PCB.
4. Specification for packaged product only.
5. $I_{CC} = 30mA$ (excluding I_{MOD}) for worst case conditions with $V_{CC} = 2.625V$, $T_A = 85^\circ C$, $I_{MOD} = 60mA$
6. Assuming $V_{CC} = 2.375V$, laser bandgap voltage = 1V, laser package inductance = 1nH, laser equivalent series resistor = 5 Ω , and damping resistor = 10 Ω .

Typical Operating Characteristics

$V_{CC} = 2.5V \pm 5\%$, $T_A = -40^{\circ}C$ to $+85^{\circ}C$. Typical values are $V_{CC} = 2.5V$, $T_A = 25^{\circ}C$, $I_{MOD} = 60mA$

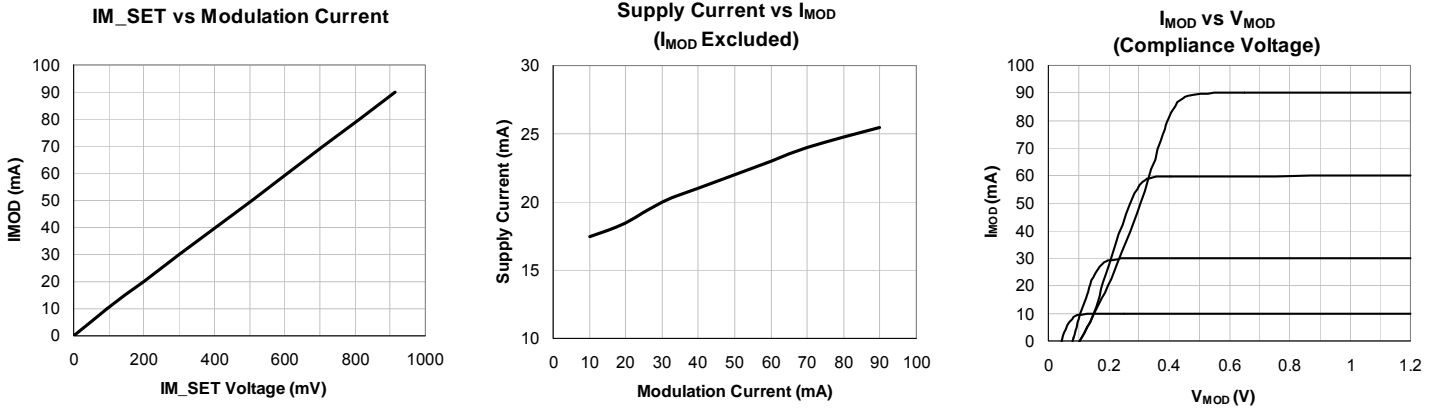

Functional Characteristics

$V_{CC} = 2.5V \pm 5\%$, $T_A = -40^{\circ}C$ to $+85^{\circ}C$. Typical values are $V_{CC} = 2.5V$, $T_A = 25^{\circ}C$, $I_{MOD} = 60mA$

PRBS-23 Input @ 1.25Gbps, I_{mod} = 60mA

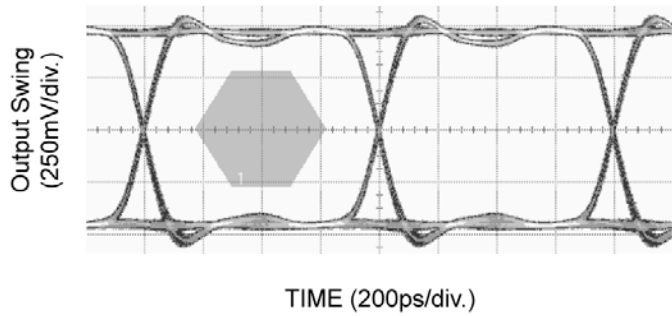

PRBS-23 Input @ 1.25Gbps, Optical

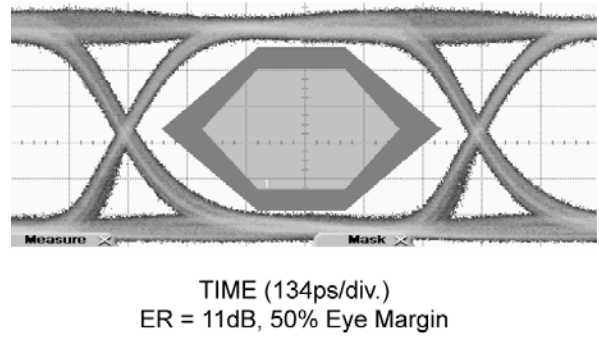

Input and Output Stages

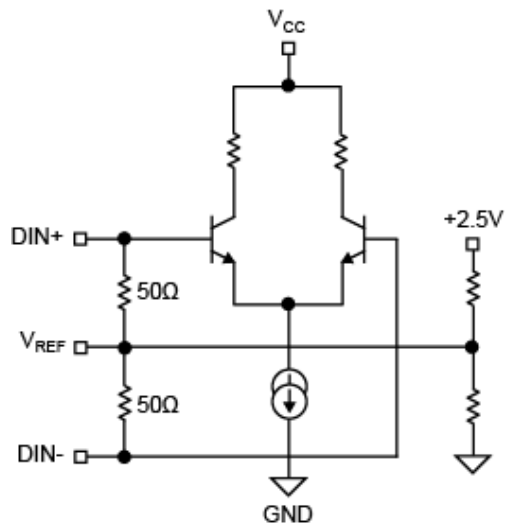

Figure 1a. Simplified Input Stage

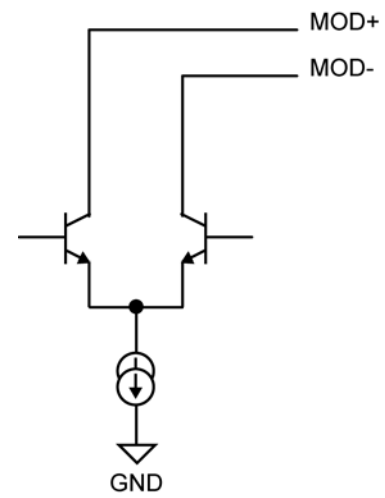

Figure 1b. Simplified Output Stage

Application Information

The typical applications diagram on the first page shows how to connect the driver to the laser single-ended. To improve transition time and laser response, the laser can be driven differentially, as shown in Figures 2 and 3. Driving the laser differentially will also minimize crosstalk with the rest of the circuitry on the board, particularly the receiver.

DC-Coupling

In addition to the low power consumption and high modulation current, the SY84782U offers a high compliance voltage. The minimum voltage needed at the output of the driver for proper operation is less than 600mV, leaving a large headroom, $V_{CC}-600mV$, to the laser with the damping resistor. To show the importance of this high compliance voltage, consider the voltage drops along the path from V_{CC} to ground through the laser, damping resistor, and driver:

$$V_{CC} = \text{Driver Headroom} + V_{Rd} + V_{laser}$$

$$V_{Rd} = R_d \times I_{MOD}$$

$$V_{laser} = V_{band-gap} + R_{laser} \times I_{MOD} + Ldi/dt$$

$$V_{band-gap} + R_{laser} \times I_{MOD} = 1.6V \text{ at maximum for a Fabry Perrot or a DFB laser.}$$

Ldi/dt is the voltage drop due to the laser parasitic inductance during I_{MOD} transitions. Assuming $L = 1nH$, $t_f = t_r = 80ps$ (measured between 20% and 80% of I_{MOD}), and $I_{MOD} = 70mA$ (42mA from 20% to 80%), then Ldi/dt will be equal to 525mV. This number can be minimized by making the laser leads as short as possible and by using the RC compensation network between the cathode of the laser and ground or across the laser driver outputs, as shown in Figure 2.

To be able to drive the laser DC-coupled with a high current, it is necessary to keep the damping resistor as small as possible. For example, if the drop due to parasitic inductance of the laser is neglected (compensated for) and the maximum drop across the laser (1.6V) considered while keeping a minimum of 600mV headroom for the driver, then the maximum damping resistor that allows a 70mA modulation current into the laser is:

$$R_{dmax} = (V_{CC}-0.6V-1.6V)/0.07A$$

The worst case will be with $V_{CC} = 3.0V$, leading to $R_{dmax} = 11.4\Omega$

On the other hand, the smaller the value of R_d , the higher is the overshoot/undershoot on the optical signal from the laser. In the circuit shown in Figure 3, the RC compensation network across the driver outputs (MOD+ and MOD-) allows the user $R_d = 10\Omega$. The optical eye diagrams at data rates of 1.25Gbps, shown in "Functional Characteristics" section, are all obtained with

the same circuit using $R_d = 10\Omega$, $R_{Comp} = 100\Omega$, and $C_{Comp} = 3pF$. The compensation network may change from one board to another and from one type of laser to another. An additional compensation network (RC) can be added at the laser cathode for further compensation and eye smoothing.

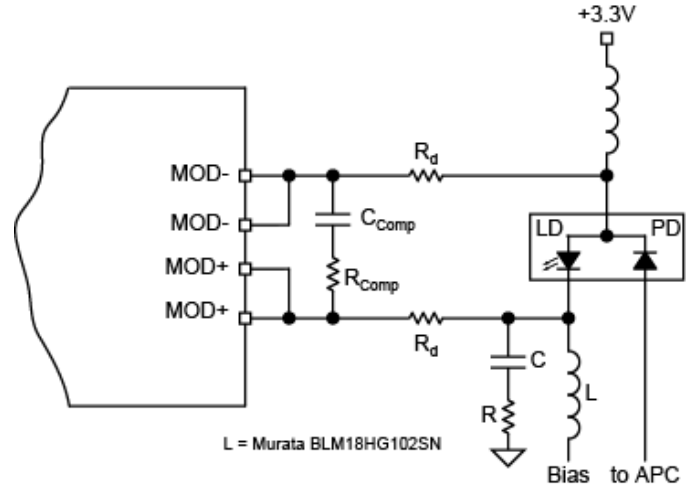

Figure 2. Laser DC-Coupled

AC-Coupling

When trying to AC-couple the laser to the driver, the headroom of the driver is no longer a problem since it is DC isolated from the laser with the coupling capacitor. At the output, the headroom of the driver is determined by the pull-up network. In Figure 3, the modulation current out of the driver is split between the pull-up network and the laser. If, for example, the total pull-up resistor is twice the sum of the damping resistor and laser equivalent series resistance, then only two thirds (2/3) of the modulation current will be used by the laser. Therefore, to keep most of the modulation current going through the laser, the total pull-up resistor must be kept as high as possible. One solution involves using an inductor alone as pull-up, presenting a high impedance path for the modulation current and zero ohm (0Ω) path for the DC current offering headroom of the driver equal to V_{CC} and almost all the modulation current goes into the laser. The inductor alone will cause signal distortion, and, to improve this phenomenon, a combination of resistors and inductors can be used (as shown on Figure 3). In this case, the headroom of the driver is $V_{CC}-R1 \times \alpha I_{MOD}$, where αI_{MOD} is the portion of the modulation current that goes through the pull-up network.

When the laser is AC-coupled to the driver, the coupling capacitor creates a low-frequency cutoff in the circuit, and its value must be chosen to be as large as possible. If the value of the cap is too high, it will slow down the fast signals edges, and conversely, if its value is too small, it won't be able to hold a constant change

between the first bit and the last bit of a long string of identical bits in a low data rate application. This leads to higher pattern-dependent jitter in the transmitter signal. 0.1 μ F is found to be good for all applications from 155Mbps to 1.25Gbps.

AC-coupling the laser to the driver brings a solution to the driver headroom problem at the expense of extra components, loss of part of the modulation current wasted in the pull-up network, and additional power consumption.

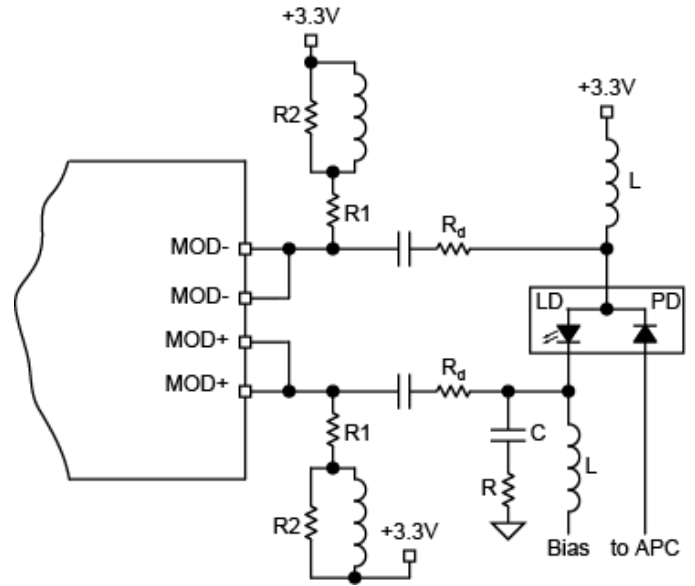
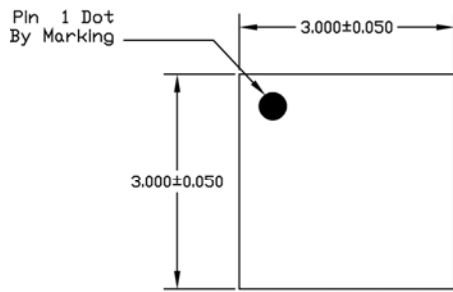
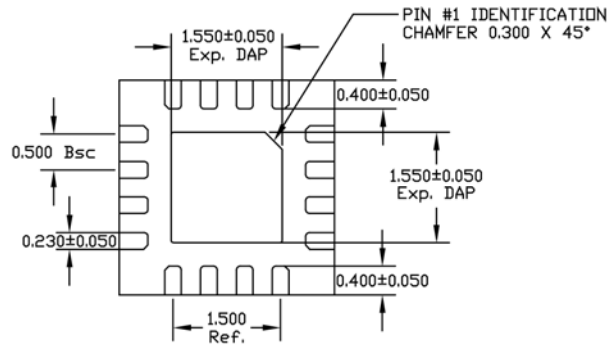

Figure 3. Laser AC-Coupled

Package Information



TOP VIEW



BOTTOM VIEW



SIDE VIEW

NOTE:

1. ALL DIMENSIONS ARE IN MILLIMETERS.
2. MAX. PACKAGE WARPAGE IS 0.05 mm.
3. MAXIMUM ALLOWABLE BURRS IS 0.076 mm IN ALL DIRECTIONS.
4. PIN #1 ID ON TOP WILL BE LASER/INK MARKED.

16-Pin (3mm x 3mm) QFN® (QFN-16)

MICREL, INC. 2180 FORTUNE DRIVE SAN JOSE, CA 95131 USA

TEL +1 (408) 944-0800 FAX +1 (408) 474-1000 WEB <http://www.micrel.com>

Micrel makes no representations or warranties with respect to the accuracy or completeness of the information furnished in this data sheet. This information is not intended as a warranty and Micrel does not assume responsibility for its use. Micrel reserves the right to change circuitry, specifications and descriptions at any time without notice. No license, whether express, implied, arising by estoppel or otherwise, to any intellectual property rights is granted by this document. Except as provided in Micrel's terms and conditions of sale for such products, Micrel assumes no liability whatsoever, and Micrel disclaims any express or implied warranty relating to the sale and/or use of Micrel products including liability or warranties relating to fitness for a particular purpose, merchantability, or infringement of any patent, copyright or other intellectual property right.

Micrel Products are not designed or authorized for use as components in life support appliances, devices or systems where malfunction of a product can reasonably be expected to result in personal injury. Life support devices or systems are devices or systems that (a) are intended for surgical implant into the body or (b) support or sustain life, and whose failure to perform can be reasonably expected to result in a significant injury to the user. A Purchaser's use or sale of Micrel Products for use in life support appliances, devices or systems is a Purchaser's own risk and Purchaser agrees to fully indemnify Micrel for any damages resulting from such use or sale.

© 2011 Micrel, Incorporated.