

PART NAME: CASE SCALE: 1:1 DATE: 3/8/63 DR. BY LS

THIS DRAWING IS THE PROPERTY OF DAVIES MOLDING COMPANY, IS SUBMITTED SOLELY AS A DESIGN OR ENGINEERING PROJECT. WE ACCEPT NO RESPONSIBILITY WHATSOEVER FOR THE PRACTICAL APPLICATION OF THE PIECES MADE TO THIS DESIGN.



DESIGNERS & MANUFACTURERS OF KNOBS, HANDLES, CASES & CUSTOM PLASTIC COMPONENTS

P/N 0220-A

BASE PART 0220-01

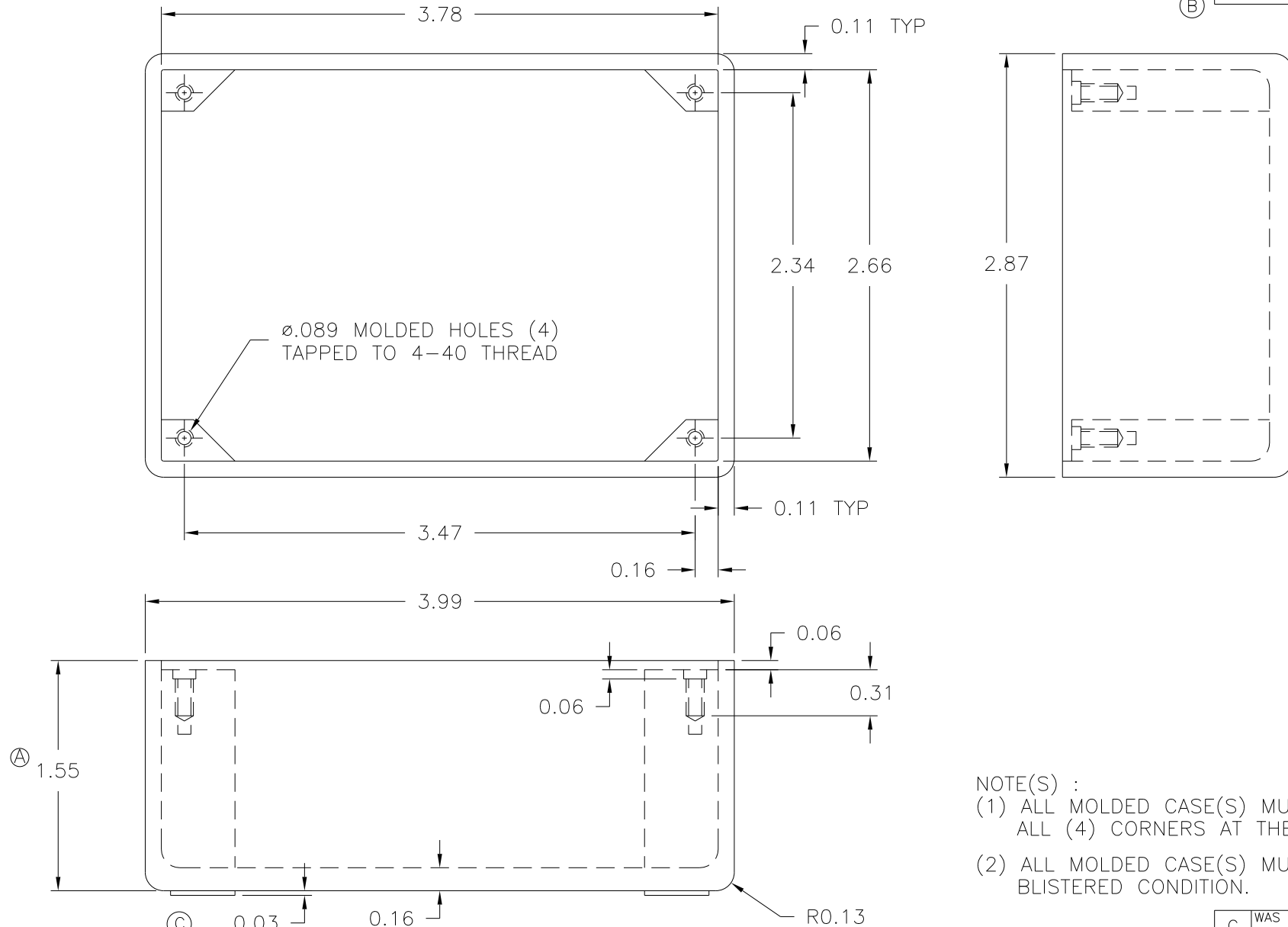

MATERIAL: #2535 PHENOLIC (B35)  
COLOR: BLACK

- NOTE(S) :
- (1) ALL MOLDED CASE(S) MUST BE ROUTED ALL (4) CORNERS AT THE MOLDING PRESS.
  - (2) ALL MOLDED CASE(S) MUST BE FREE OF BLISTERED CONDITION.

TOLERANCES: UNLESS OTHERWISE SPECIFIED	DO NOT SCALE DRAWING	C	WAS G.P. PHENOLIC (B11)	JAM	3/18/16
		B	ADDED BASE PART	JAM	2/27/14
DECIMALS: X.XXX ± .005 X.XX ± .015	MM: X.XX ± 0.15MM X.X ± 0.4MM	-	RE-DID REDRAW	TL	10/12/99
		A	ADDED 1 9/16	MP	1/3/97
FRACTIONS ± 1/64	ANG. ± 1°	-	CAD REDRAW	HD	3/31/95
CHANGES					